



# HE365 Powered Flow-Through Humidifier

## INSTALLATION INSTRUCTIONS

### READ AND SAVE THESE INSTRUCTIONS

### APPLICATION

The HE365 Powered Flow-Through Humidifier works with the warm air furnace blower to provide humidification for the whole house. The HE365 works with virtually any Honeywell Home humidity control.

### INSTALLATION

#### When Installing this Product...

1. Read these instructions carefully. Failure to follow them could damage the product or cause a hazardous condition.
2. Check the ratings given in the instructions and on the product to make sure the product is suitable for your application.
3. Installer must be a trained, experienced service technician.
4. After installation is complete, check out product operation as provided in these instructions.

#### **CAUTION** Hazardous Voltage.

Improper drilling can cause equipment damage or personal injury. Do not cut or drill into any air conditioning or electrical accessory.

#### **CAUTION** Chemical Hazard.

Can cause personal injury or equipment damage. Do not use any line connected to an air conditioner.

#### **CAUTION** Freezing Water, Flooding or Static Pressure Hazard.

- Can cause water damage or permanent equipment damage.
- Locate the humidifier where the ambient temperature is between 32°F (0°C) and 160°F (71°C) or property damage can occur.
  - Do not install humidifier where freezing temperatures could occur.
  - Be sure supply plenum static pressure is no greater than 0.4 in. wc and water pressure is no greater than 125 psi.

#### IMPORTANT

Mount the humidifier at least 3 in. (76 mm) above the furnace jacket to allow adequate space for the drain line. Check that there is adequate space above the humidifier to remove and install the humidifier cover. Do not install on a furnace jacket.

1. Determine the best location for the humidifier and draw a level line on the plenum. See Fig. 1 and 2.

#### IMPORTANT

To assure optimal product performance, be sure the template is level before marking.

2. Tape this piece of paper in position as your template and trace around the template.
3. Remove the template and carefully cut the rectangular opening.
4. Loosen the thumbscrew on the bottom of the humidifier and remove the cover.
5. Remove the humidifier pad assembly by grasping the top of the tray and pulling the assembly out of the housing. See Fig. 3.
6. Position the securing clips as shown in Fig. 4.

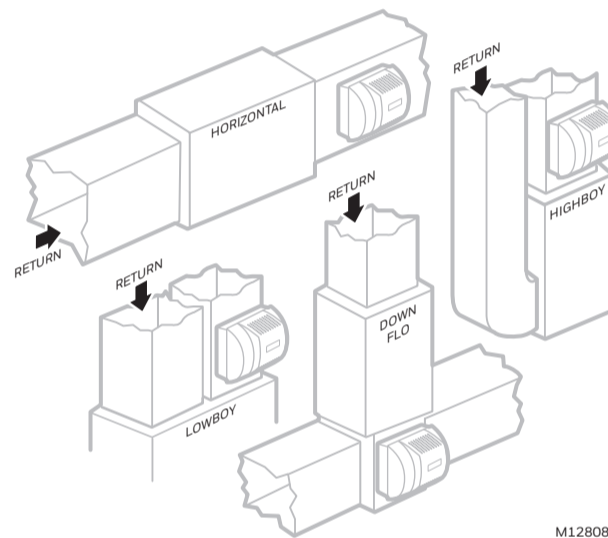

Fig. 1. Typical humidifier installation locations.

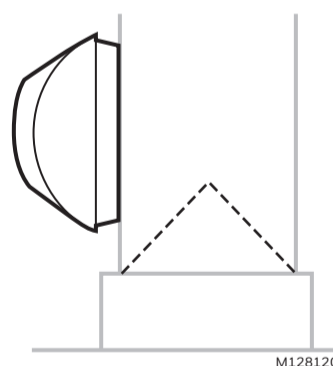

Fig. 2. HE360 Humidifier location in relation to air conditioning cooling coils.

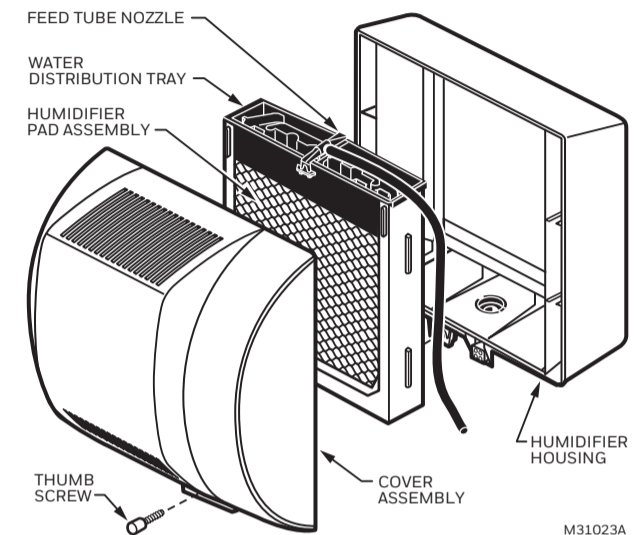

Fig. 3. Humidifier components.

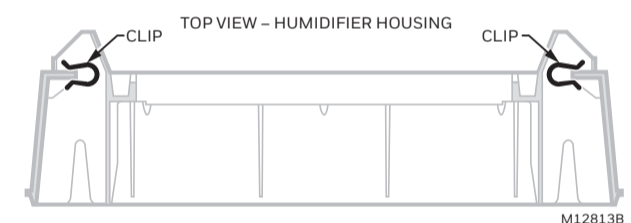

Fig. 4. Position securing clips.

7. Position the humidifier housing in the hole (be sure it is level), so the locking tabs are in place on the upper and lower sheet metal edge of the hole.
8. Push in securing clips until completely seated.
9. Drill holes and install the three sheet metal screws at the top of the humidifier housing. Secure the housing with the three remaining screws.
10. Reinstall the humidifier pad assembly in the humidifier housing.

#### IMPORTANT

For proper operation, be sure the mark on the end of the humidifier pad is facing up. Check that the water feed tube is placed in the guide slots of the humidifier housing.

11. Hook the top of the cover to the housing and secure with the thumbscrew located at the bottom of the cover.

Template (entire sheet)

Template (entire sheet)



## WIRING

### ⚠ WARNING

#### Voltage Hazard.

Moving parts can cause electrical shock and injury.

- Disconnect power supply before installation or servicing.
  - This device contains a moving fan blade; do not operate the humidifier without the cover securely attached.
- All wiring must comply with applicable local codes, ordinances and regulations.

**For H6062 humidistat, use figures 5 or 6 and follow the notes below. For mechanical humidistat, use figures 5, 6, or 8 and follow the notes below.**

#### IMPORTANT

- Select models of fan centers include humidifier taps so the current sensing relay or sail switch is not needed.
- If not using a current sensing relay or sail switch, the 120V humidifier plug must be energized during blower motor cycles for proper operation.
- Red wire connections on humidifier are used for the H6062 digital humidity controller but are not used for mechanical humidistats or IAQ thermostats.

For additional mounting and wiring information, refer to the humidistat installation instructions.

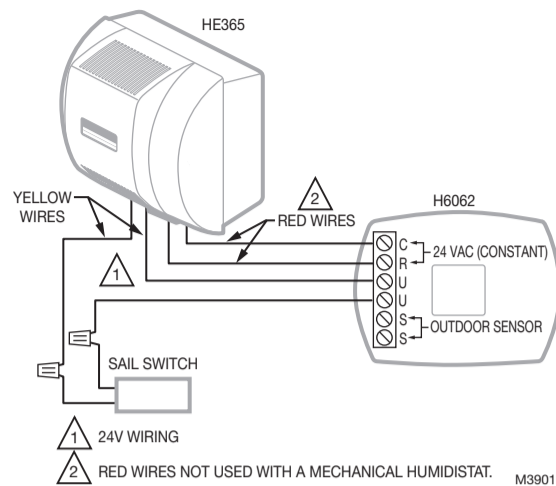

**Fig. 5. Typical wiring diagram of sail switch with humidifier.**

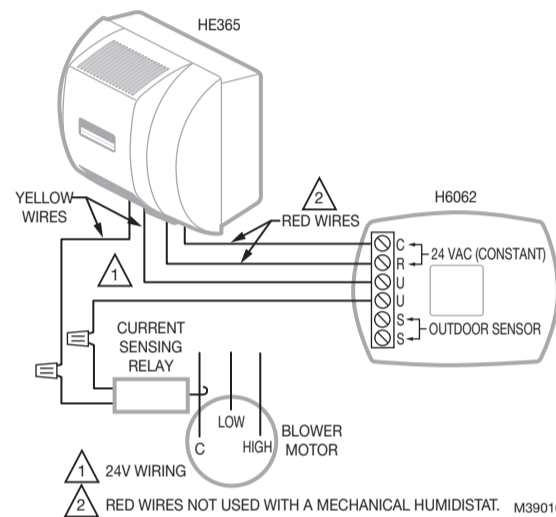

**Fig. 6. Typical wiring diagram of current sensing relay with humidifier.**

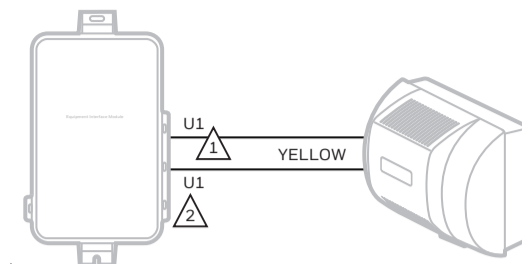

**Fig. 7. Typical wiring diagram for humidifier using TH8321R RedLINK VisionPRO or Prestige with EIM.**

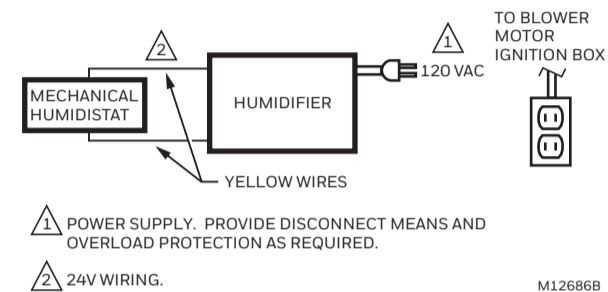

**Fig. 8. Typical wiring diagram for humidifier using fan control to cycle blower motor fan and humidifier simultaneously.**

## CHECKOUT

1. Set the thermostat setpoint 10°F (6°C) above the room temperature.
2. Set the humidity control to a high humidity setting, or place the setting in the test position.
3. Observe the water running out of the drain line to be sure the humidifier is working correctly.
4. Check for leaks.
5. Reset the thermostat to a comfortable setting or the Automatic Humidity Control to the desired frost factor setting.

NOTE: The furnace blower must be on for the humidifier to operate.