

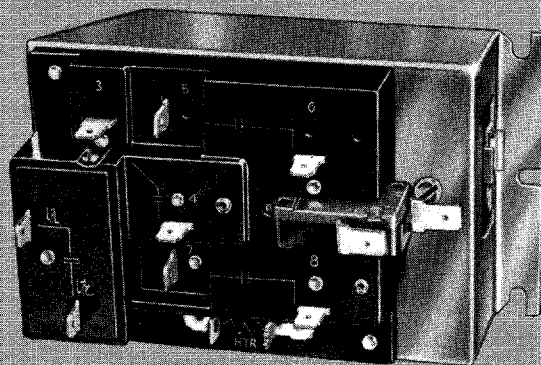
# Honeywell

R8330 ELECTRIC FURNACE SEQUENCERS SWITCH A FAN AND ELECTRIC HEATING ELEMENTS ON AND OFF IN SEQUENCE.

- Single unit control of heating elements and fan reduces control space requirements and wiring in furnace.
- Elements sequence on within 2 minutes and off within 4 minutes.
- Meet latest EEI-NEMA standards.
- Multipoise mounting of control.
- All models are same size.
- Designed for easy mounting with tab and single screw.
- Devices are ambient compensated for minus 20 to plus 162 F [minus 29 to plus 71 C].
- Models available with low VA pilot duty rating for remote fan operation.
- Isolated fan or combination rated models available.
- Quick-connect terminals for easy wiring.
- Designed for quiet, reliable operation.
- Thermostat current draw is constant (0.4 amp).
- Model line offers complete range of control choice to meet all application requirements.

L.H.  
REV. 7-75 (.086)

## ELECTRIC FURNACE SEQUENCERS



R8330D

## R8330A-H,J,K

# SPECIFICATIONS

## TRADELINE MODELS

Tradeline models are selected and packaged for ease of handling, ease of stocking, and maximum replacement value. Tradeline model specifications are the same as those of standard models except as noted below.

**MODEL: R8330D1039 Electric Furnace Sequencer.**

This single model replaces all 10 of the other models in our line.

**ADDITIONAL FEATURES:**

- Includes special Tradeline accessories.
- Mounting screws.

- Mounting nuts and bolts.
- Double male quick-connect adapters.
- New replacement quick-connects.
- Jumper leadwires.

- Tradeline pack with cross reference label and special instruction sheet.

## STANDARD MODELS

**MODELS:**

**R8330A Electric Furnace Sequencer**—3-switch model sequences 2 elements and fan on and off. Fan interlock switches fan on with first element and off with last element.

**R8330B Electric Furnace Sequencer**—4-switch model sequences 3 elements and fan on and off. Fan interlock switches fan on with first element and off with last element.

**R8330C Electric Furnace Sequencer**—same as R8330A with auxiliary switch to energize a second R8330.

**R8330D Electric Furnace Sequencer**—same as R8330B with auxiliary switch to energize a second R8330.

**R8330E Electric Furnace Sequencer**—2-switch combination rated model sequences 2 elements and fan on and off. Fan and first element controlled by first load switch (terminals 3-4).

**R8330F Electric Furnace Sequencer**—3-switch combination rated model sequences 3 elements and

fan on and off. Fan and first element are controlled by the first load switch (terminals 3-4).

**R8330G Electric Furnace Sequencer**—same as R8330E with auxiliary switch to energize a second R8330.

**R8330H Electric Furnace Sequencer**—same as R8330F with auxiliary switch to energize a second R8330.

**R8330J Electric Furnace Sequencer**—2-switch model sequences one element and fan on and off. Fan interlock switches fan and element on and off simultaneously.

**R8330K Electric Furnace Sequencer**—1-switch combination rated model sequences 1 element and fan on and off. Fan and first element controlled by first load switch (terminals 3-4). Standard model is used in single element furnaces. A model with special on and off timing is available for use in 4-element, multiple sequencer, combination rated applications.

**TABLE I—MODEL SUMMARY**

MODEL	ISOLATED FAN SWITCH	LOAD SWITCH NO. 1 CONTACTS 3-4	LOAD SWITCH NO. 2 CONTACTS 5-6	LOAD SWITCH NO. 3 CONTACTS 7-8	AUXILIARY SWITCH
R8330A	X	X	—	X	—
R8330B	X	X	X	X	—
R8330C	X	X	—	X	X
R8330D	X	X	X	X	X
R8330E	—	X	—	X	—
R8330F	—	X	X	X	—
R8330G	—	X	—	X	X
R8330H	—	X	X	X	X
R8330J	X	X	—	—	—
R8330K	—	X	—	—	—

*(continued on page 3)*

# ORDERING INFORMATION

**WHEN ORDERING REFER TO THE PRICE SHEETS FOR COMPLETE ORDERING SPECIFICATION NUMBER, OR . . .**

**SPECIFY—**

1. MODEL NUMBER.
2. ACCESSORY CONTROLS, IF DESIRED.

**ORDER FROM—**

1. YOUR USUAL SOURCE, OR
2. HONEYWELL  
1885 DOUGLAS DRIVE NORTH  
MINNEAPOLIS, MINNESOTA 55422  
(IN CANADA—HONEYWELL CONTROLS LIMITED  
740 ELLESMERE ROAD  
SCARBOROUGH, ONTARIO)  
INTERNATIONAL SALES AND SERVICE OFFICES  
IN ALL PRINCIPAL CITIES OF THE WORLD.

**ELECTRICAL RATINGS:**

Load Contact Rating (all models)–

VOLTS AC	CONTACT RATINGS (3-4, 5-6, AND 7-8)		COMBINED RESISTIVE AND INDUCTIVE CONTACT RATINGS (3-4 ONLY) (UL)			
	RESISTIVE		RESISTIVE		INDUCTIVE	
	AMP	KW	AMP	KW	AFL	ALR
208	25.0	5.2	20.8	4.3	5.5	15.0
240	25.0	6.0	20.8	5.0	5.5	15.0
277	21.7	6.0	18.0	5.0	3.6	8.6

Fan contacts (F1, F2)–R8330A,B,C,D, and J–

VOLTS AC	INDUCTIVE AMP	
	FULL LOAD	LOCKED ROTOR
120 <sup>a</sup>	7.2	43.2
120, 208, 240 <sup>b</sup>	6.9	41.4
277	4.9	29.4

<sup>a</sup>1/3 hp.

<sup>b</sup>3/4 hp.

Pilot Duty Rating–62.5 VA at 24V ac; special models available with pilot duty rating of 3.5-62.5 VA on fan contacts at 24V ac.

AUXILIARY SWITCH (R8330C,D,G, and H only): 3.6 amp full load; 21.6 amp locked rotor at 240V ac; 5 amp resistive at 24, 120, 208, and 240V ac; 35 VA pilot duty at 24V ac.

CONTROL VOLTAGE: 24V ac; 0.40 amp.

MINIMUM AMBIENT TEMPERATURE: Minus 20 F [minus 29 C].

MAXIMUM AMBIENT TEMPERATURE: Plus 162 F [plus 71 C] (Underwriters Laboratories Inc.).

DIMENSIONS: See Fig. 1.

TIMING: 10 seconds minimum between stages at 106 percent rated voltage and 120 F [49 C] ambient. All stages of single control sequence on within two minutes and off within four minutes at nominal voltage and ambient temperature. Timings comply with new EEI-NEMA Standards for Local Control for Use on Central Electric Heating Systems.

SYSTEM TRANSFORMER REQUIREMENTS: 24V ac secondary. Current remains constant during thermostat ON cycle. See thermostat heat anticipator settings for circuit current draw. One sequencer requires 20 VA transformer. A 40 VA transformer or larger must be used when two or more R8330's are used.

MOUNTING MEANS: Mounting tab inserted into 3/16 inch hole and secured with a single No. 10 screw (not included). Mount on steel plate up to 1/16 inch thick.

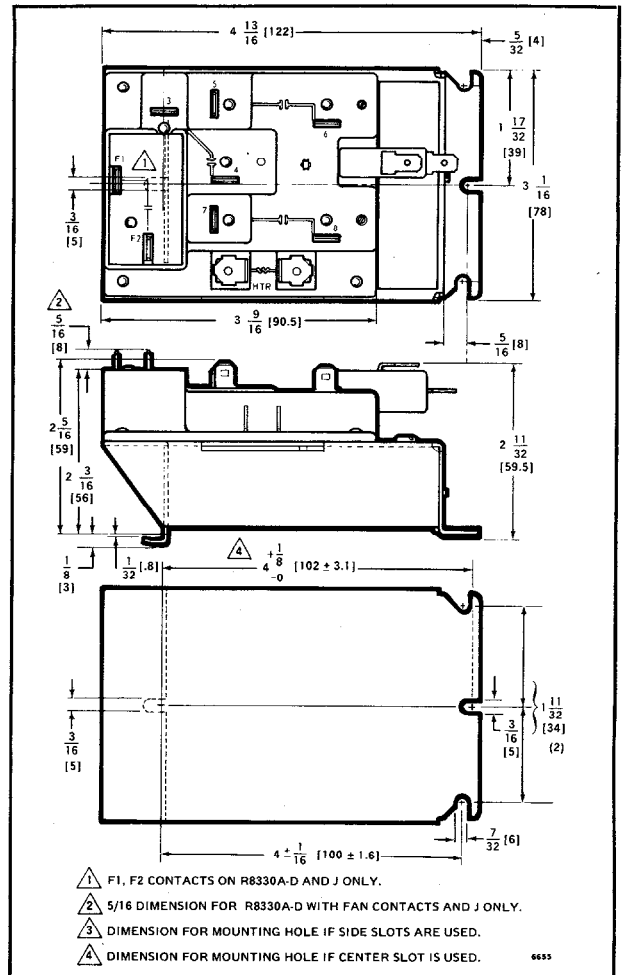
**WIRING CONNECTIONS:**

- Fan and Elements–1/4 inch male quick-connects.
- Heater–1/4 inch male quick-connects.
- Auxiliary Switch (R8330C,D,G, and H only)–1/4 inch male quick-connects.

UNDERWRITERS LABORATORIES INC. COMPONENT RECOGNIZED: File No. E55260, Guide No. XAPX2.

CANADIAN STANDARDS ASSOCIATION CERTIFIED: File No. LR1620.

THERMOSTAT HEAT ANTICIPATOR SETTING: 0.4 amp. If combination hookups are used (see wiring diagrams), set heat anticipator to the values given in Table II.



**FIG. 1—R8330 DIMENSIONS, ALL MODELS IN INCHES [MILLIMETERS IN BRACKETS].**

**ACCESSORY CONTROLS:**

1. AT20, AT40, and AT72 Transformers–25V ac open secondary. Used to supply power to systems using R8330 Sequencers; AT40 or larger must be used when two or more R8330's are used. Refer to wiring hookups and transformer specification sheets for additional information.

2. T87F Thermostat for heating systems; use with Q539 Subbase for heating-cooling systems. T872 Thermostat with Q672 Subbase for 1- or 2-stage heating and/or cooling applications. Refer to applicable specification sheets for additional information.

TABLE II

NUMBER FURNACE ELEMENTS	MODELS R8330 REQUIRED										FAN CHANGE- OVER RELAY <sup>d</sup>	FAN INTER- LOCK RELAY	THERMOSTAT HEAT ANTICIPATOR SETTING (CURRENT DRAW, AMPS)			FOR WIRING SEE FIG.
	A	B	C	D	E	F	G	H	J	K			SINGLE- STAGE	TWO-STAGE		
														STAGE 1	STAGE 2	
1	-	-	-	-	-	-	-	-	1	-	spdt	-	0.4	-	-	3
1	-	-	-	-	-	-	-	-	-	1	dpst	-	0.4	-	-	4
2	1	-	-	-	-	-	-	-	-	-	spdt	-	0.4	-	-	5
2	-	-	-	-	1	-	-	-	-	-	dpst	-	0.4	-	-	6
3	-	1	-	-	-	-	-	-	-	-	spdt	-	0.4	-	-	7
3	-	-	-	-	-	1	-	-	-	-	dpst	-	0.4	-	-	8
3	-	-	-	-	1	-	-	-	-	1 <sup>a</sup>	dpst	-	0.8 <sup>c</sup>	-	-	-
3	-	-	-	-	1	-	1	-	-	-	dpst	-	0.4	0.4	0.4	9
4	-	-	-	1	-	-	-	-	1	-	spdt	-	0.4	0.4	0.4	10
4	1	-	1	-	-	-	-	-	-	-	spdt	-	0.4	0.4	0.4	-
4	-	-	-	-	-	1	-	-	-	1 <sup>a</sup>	dpst	-	0.8 <sup>c</sup>	0.4	0.4	11
4	-	-	-	-	1	-	1	-	-	-	dpst	spdt <sup>b</sup>	0.4	0.4	0.4	-
4	-	-	-	-	-	-	-	1	-	1	dpst	spdt <sup>b</sup>	0.4	0.4	0.4	-
4	-	-	-	-	1	-	-	1	-	-	dpst	-	0.4	0.4	0.4	12
4	-	-	-	-	-	1	1	-	-	-	dpst	-	0.4	0.4	0.4	-
5	1	-	-	1	-	-	-	-	-	-	spdt	-	0.4	0.4	0.4	13
5	-	-	-	-	1	-	-	1	-	-	dpst	spdt <sup>b</sup>	0.4	0.4	0.4	14
5	-	-	-	-	-	1	-	1	-	-	dpst	-	0.4	0.4	0.4	15
6	-	1	-	1	-	-	-	-	-	-	spdt	-	0.4	0.4	0.4	16
6	-	-	-	-	-	1	-	1	-	-	dpst	spdt <sup>b</sup>	0.4	0.4	0.4	17
6	-	-	-	-	1	-	2	-	-	-	dpst	spdt <sup>b</sup>	0.4	0.4	0.4	-
6	-	-	1	1	-	-	-	-	1	-	spdt	-	0.4	0.4	0.4	-
6	1	-	2	-	-	-	-	-	-	-	spdt	-	0.4	0.4	0.4	-
7	-	-	-	2	-	-	-	-	1	-	spdt	-	0.4	0.4	0.4	-
7	-	-	-	-	-	-	-	2	-	1	dpst	spdt <sup>b</sup>	0.4	0.4	0.4	-
7	-	-	-	-	1	-	1	1	-	-	dpst	spdt <sup>b</sup>	0.4	0.4	0.4	-
7	-	-	-	-	-	1	2	-	-	-	dpst	spdt <sup>b</sup>	0.4	0.4	0.4	-
7	-	1	2	-	-	-	-	-	-	-	spdt	-	0.4	0.4	0.4	-
7	1	-	1	1	-	-	-	-	-	-	spdt	-	0.4	0.4	0.4	-
7	-	-	-	-	-	-	-	2	-	1 <sup>a</sup>	dpst	spdt <sup>b</sup>	0.4	0.4	0.8	-

<sup>a</sup>Use R8330K—special timing specifications.

<sup>b</sup>Fan interlock relays required for single-stage thermostat operation only.

<sup>c</sup>NOTE: Two sequencer heaters wired in parallel.

<sup>d</sup>Two-speed fan changeover relay switches fan from low speed to high speed when subbase switch is changed from heat to cool.

# INSTALLATION

## CAUTION

1. Installer must be a trained, experienced serviceman.
2. Disconnect power supply before connecting wiring to prevent electrical shock and equipment damage.
3. Conduct a thorough checkout after the installation is complete.

## LOCATION AND MOUNTING

The design of the furnace will determine the control location. Make sure that the area selected is within the control's ambient temperature range of minus 20 to plus 150 F [minus 29 to plus 71 C].

Mount the control on steel plate up to 1/16 inch thick. The R8330 may be mounted in any position. Note the locations of the mounting tab and screw slot (see Fig. 1). Drill a 3/16 inch hole for the mounting tab and a hole for a No. 10 self-tapping sheetmetal screw. Slip tab into place and fasten R8330 with screw in mounting slot.

**WIRING**

**CAUTION**

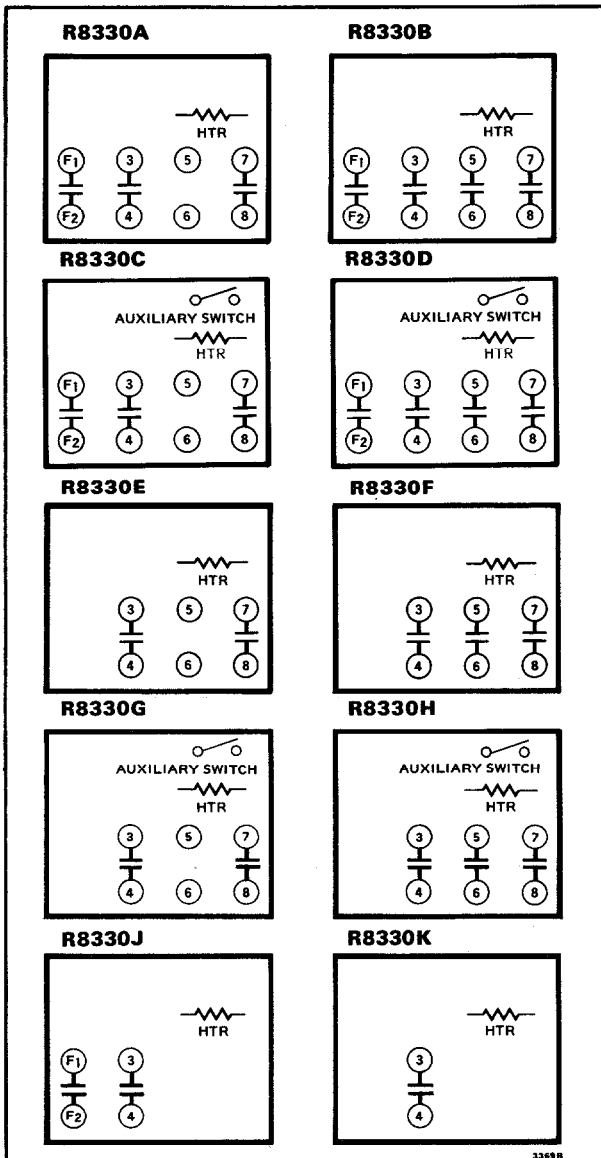
Disconnect power supply to prevent electrical shock and equipment damage.

**IMPORTANT**

The terminals on these controls are approved for use with copper wire only.

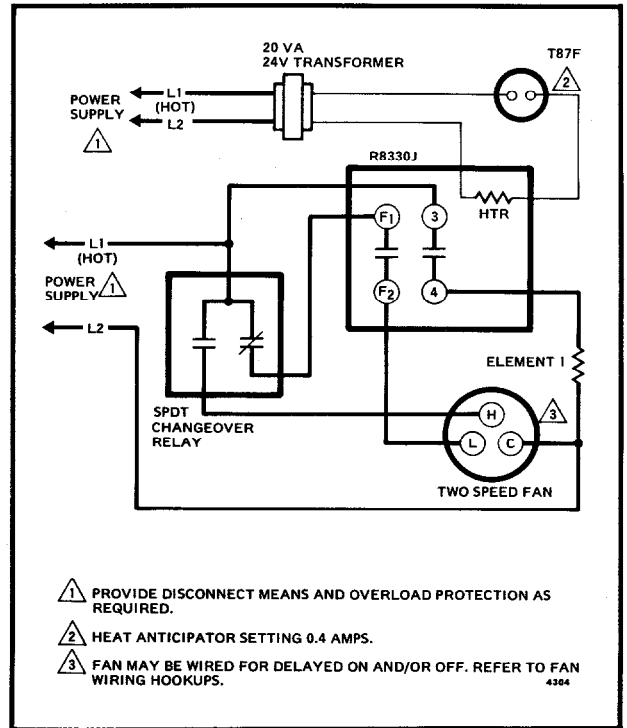
All wiring must comply with applicable codes and ordinances. Refer to manufacturer's wiring information if available. Terminal identifications are molded in the R8330 base for wiring convenience. Adjust the thermostat heat anticipator to match the circuit current draw (see SPECIFICATIONS).

Figs. 3-17 show typical hookups using the R8330 in systems with up to six elements. Optional methods of wiring the fan to provide delayed on and/or off are shown in Figs. 18-19.

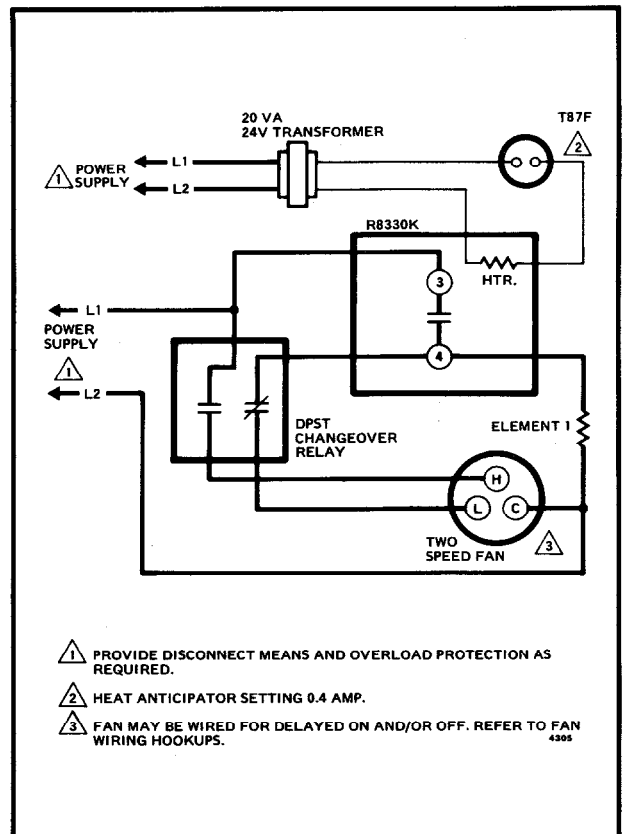


**FIG. 2—INTERNAL SCHEMATICS OF R8330 FURNACE SEQUENCERS.**

**ONE-ELEMENT FURNACES**

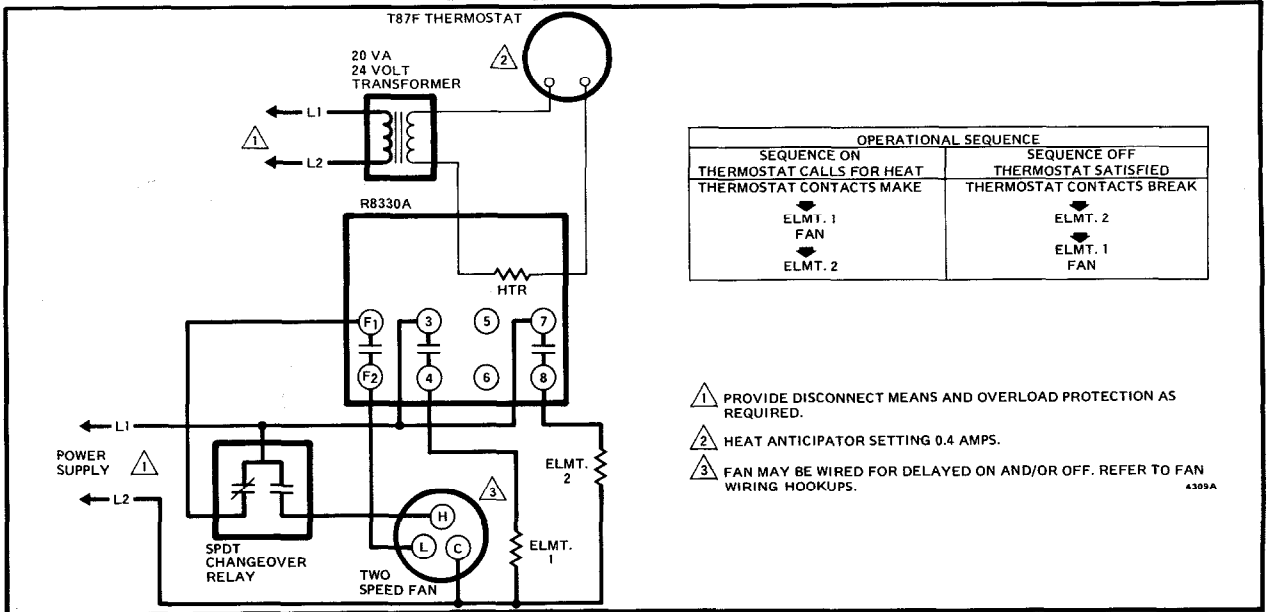


**FIG. 3—WIRING SCHEMATIC FOR A SINGLE-ELEMENT SYSTEM—ISOLATED FAN.**

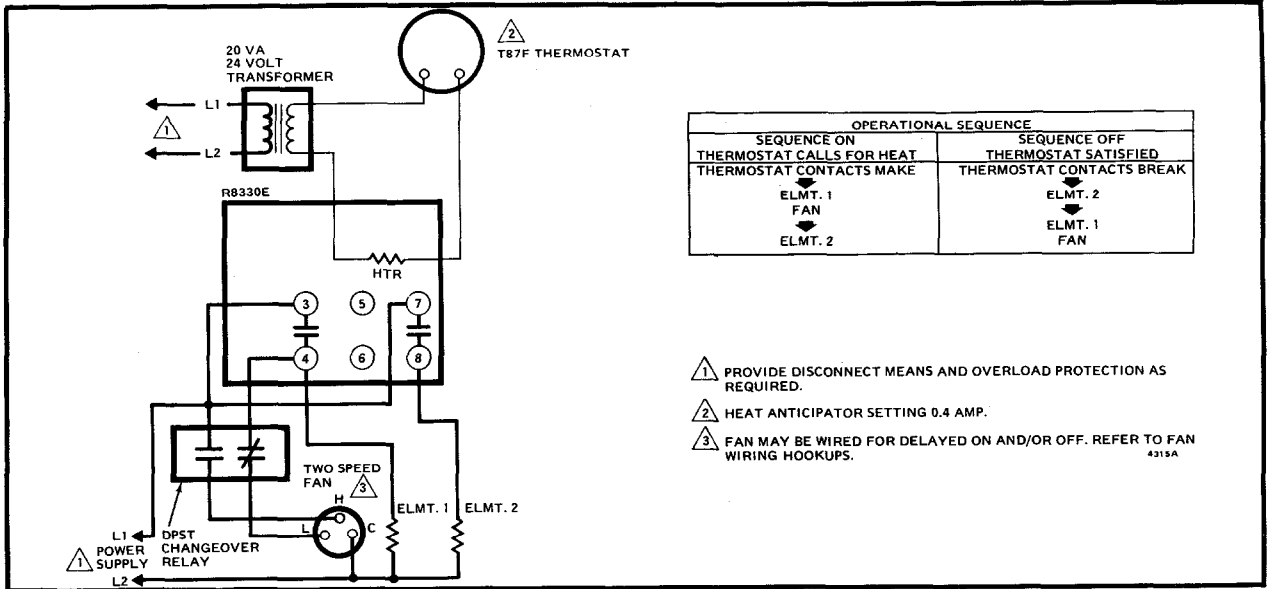


**FIG. 4—WIRING SCHEMATIC FOR A SINGLE-ELEMENT SYSTEM—COMBINATION RATED.**

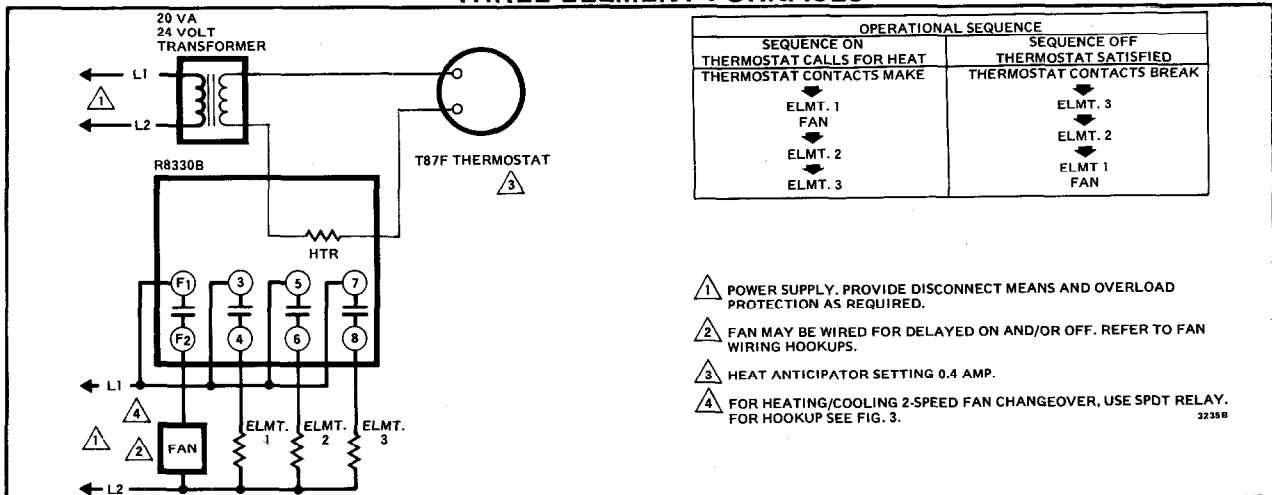
## TWO-ELEMENT FURNACES



**FIG. 5—WIRING SCHEMATIC FOR A TWO-ELEMENT SYSTEM—ISOLATED FAN.**



**FIG. 6—WIRING SCHEMATIC FOR A TWO-ELEMENT SYSTEM—COMBINATION RATED.  
THREE-ELEMENT FURNACES**



**FIG. 7—WIRING SCHEMATIC FOR A THREE-ELEMENT SYSTEM—ISOLATED FAN.**

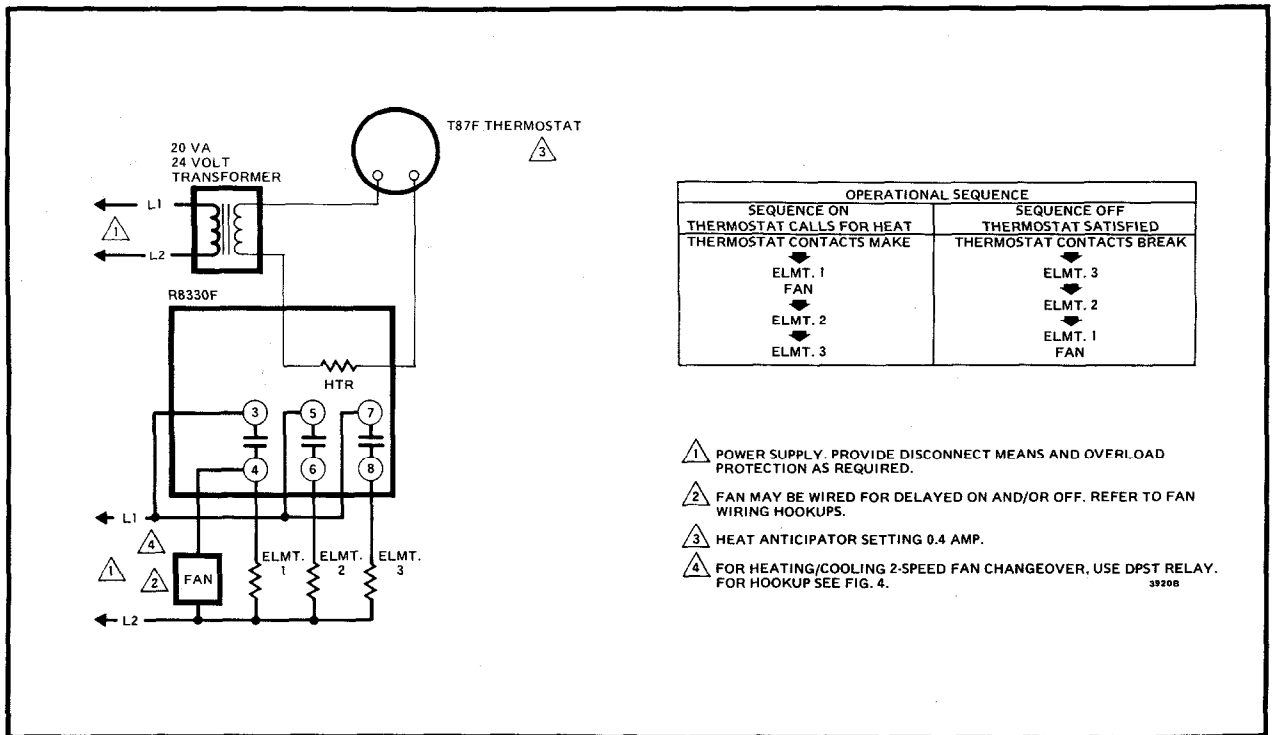


FIG. 8—WIRING SCHEMATIC FOR A THREE-ELEMENT SYSTEM—COMBINATION RATED.

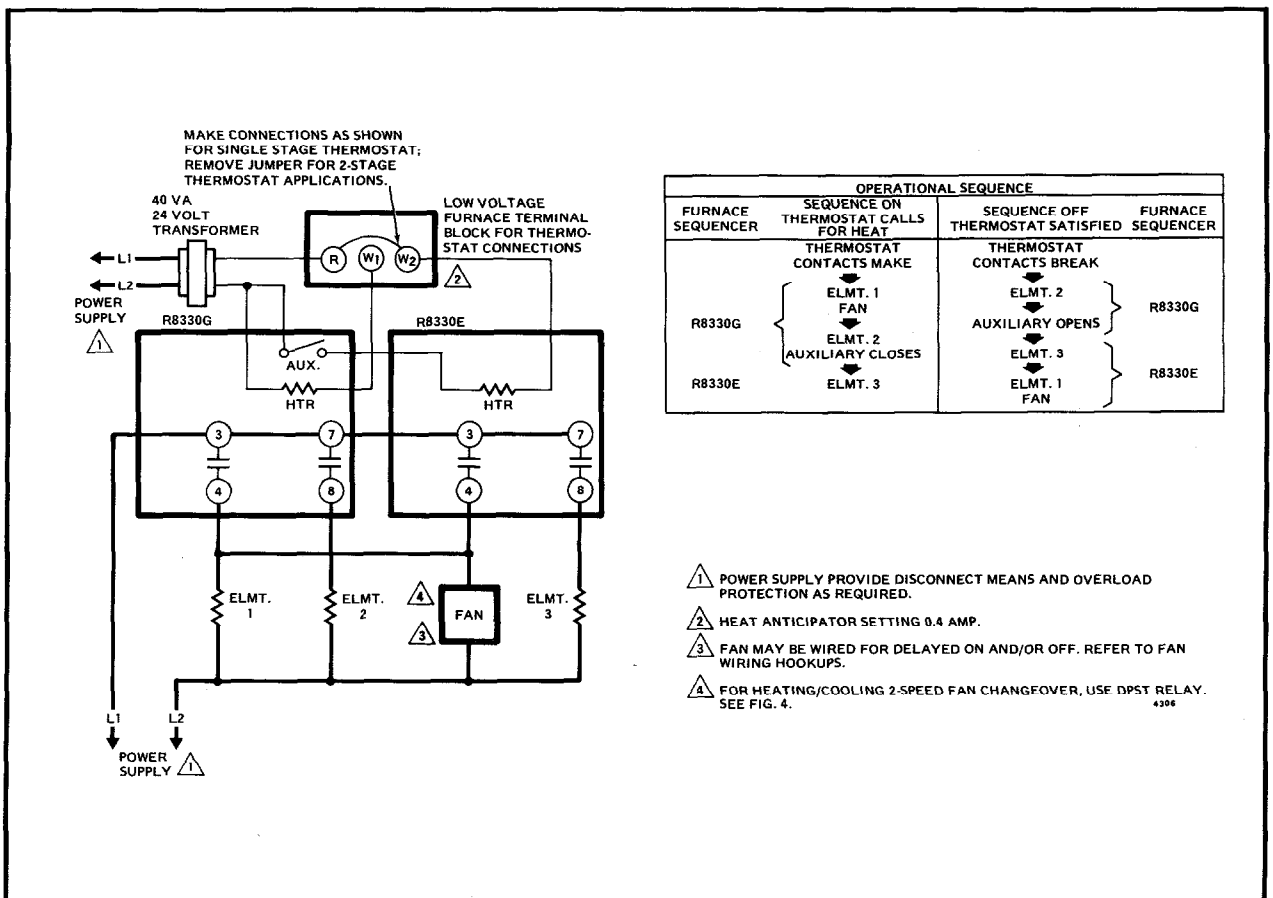
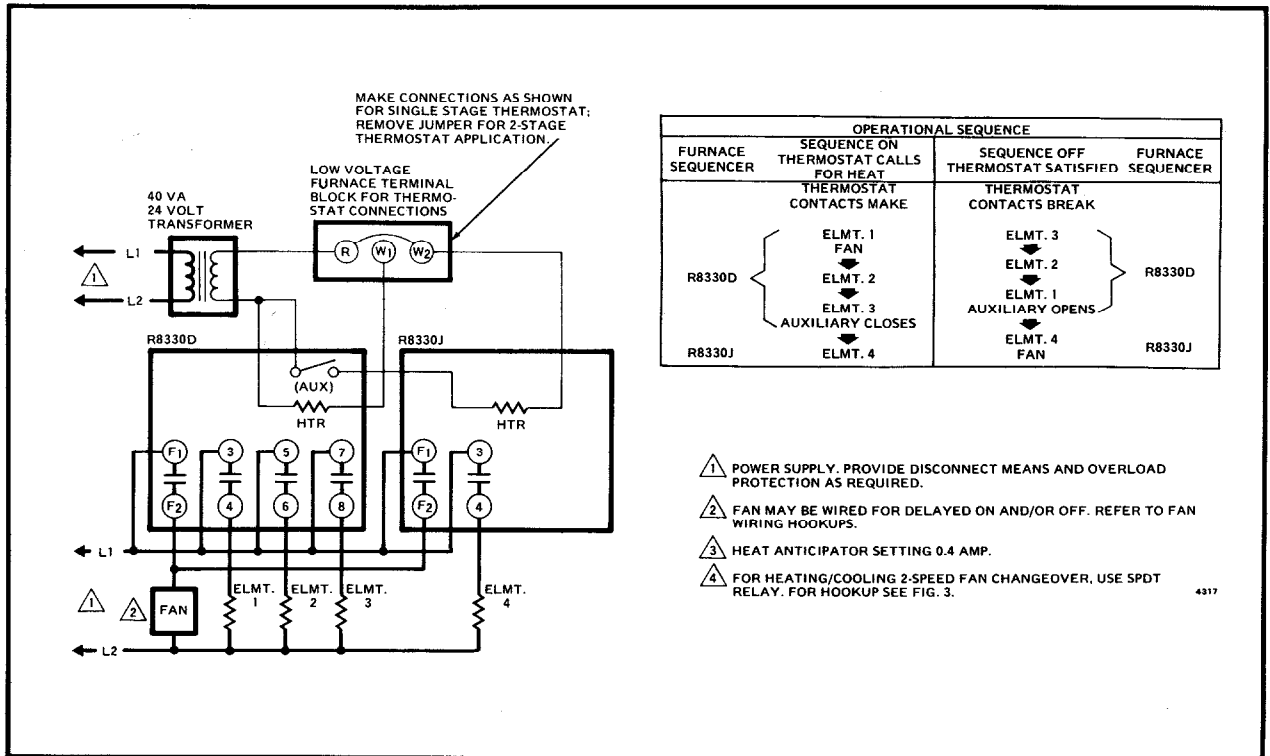
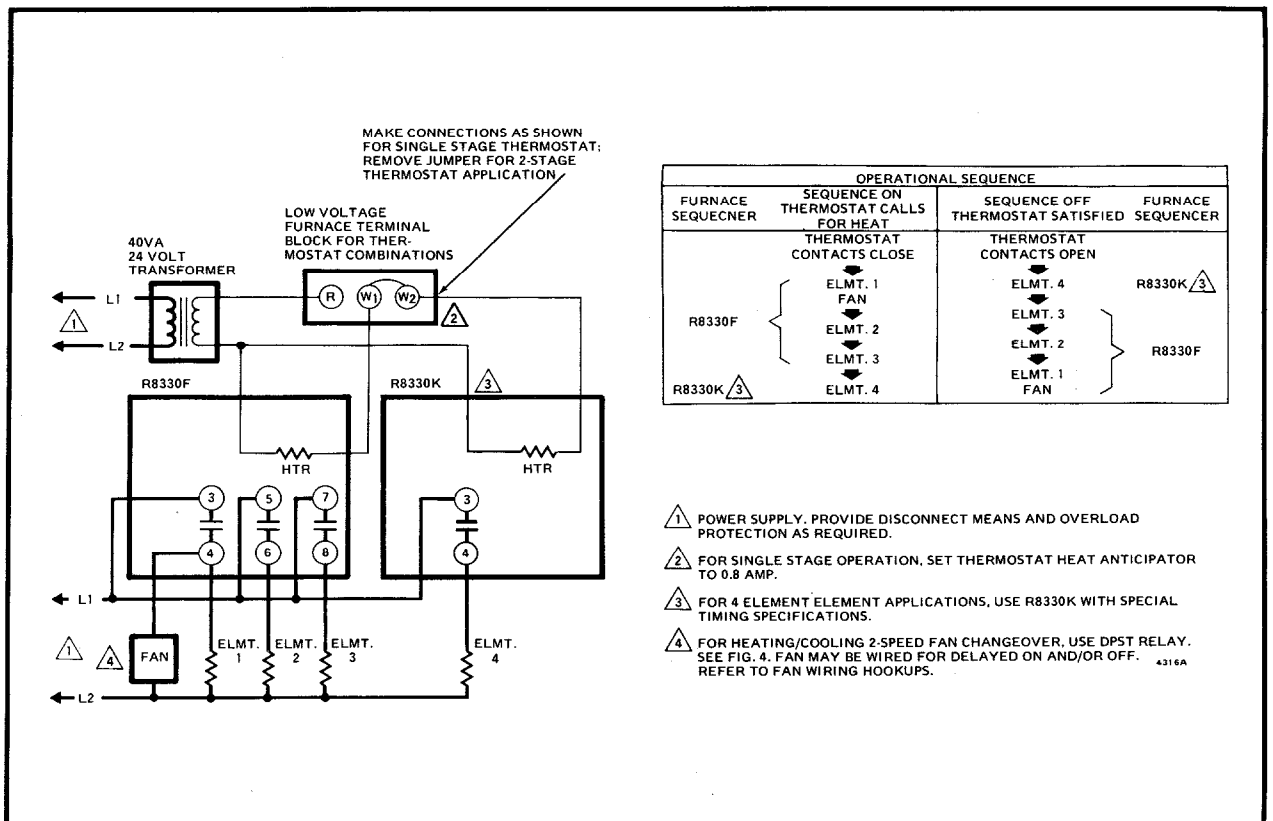


FIG. 9—WIRING SCHEMATIC FOR A THREE-ELEMENT SYSTEM—COMBINATION RATED.

## FOUR-ELEMENT FURNACES



**FIG. 10—WIRING SCHEMATIC FOR A FOUR-ELEMENT SYSTEM—ISOLATED FAN.**



**FIG. 11—WIRING SCHEMATIC FOR A FOUR-ELEMENT SYSTEM—COMBINATION RATED.**

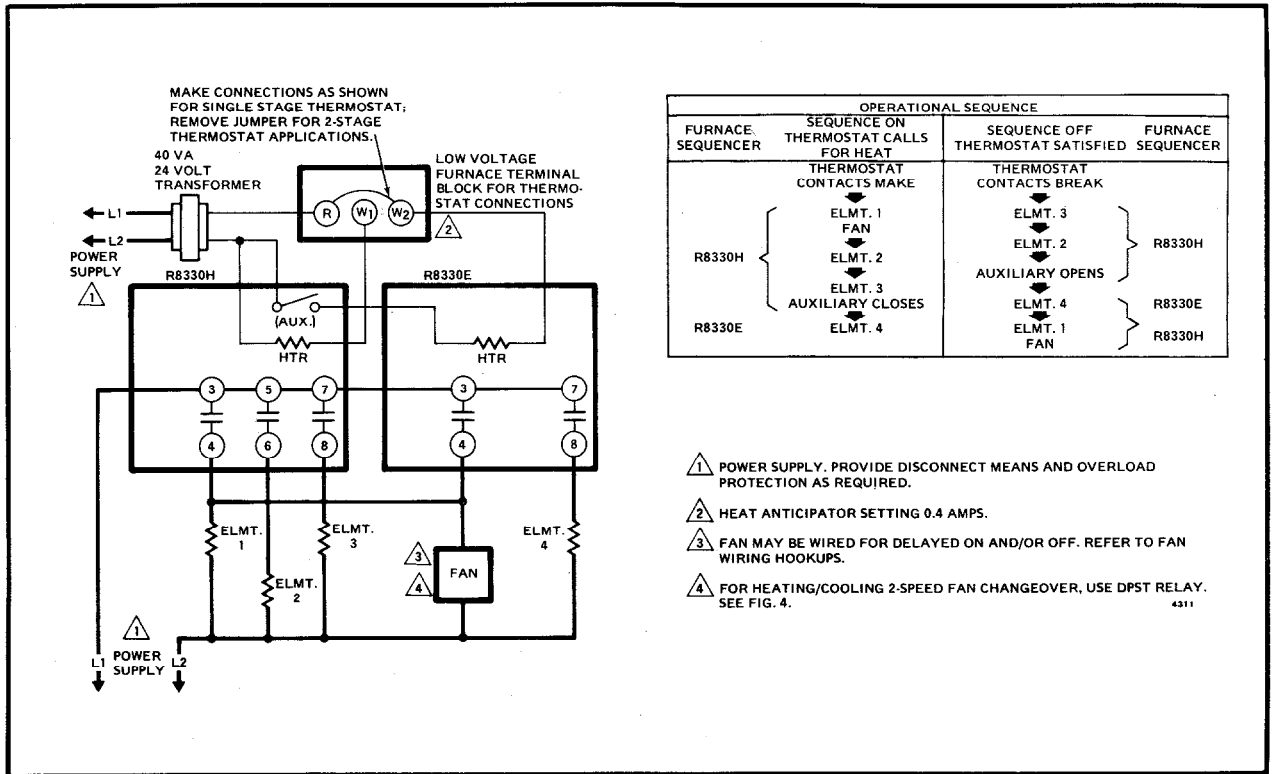


FIG. 12—WIRING SCHEMATIC FOR A FOUR-ELEMENT FURNACE—COMBINATION RATED.

### FIVE-ELEMENT FURNACES

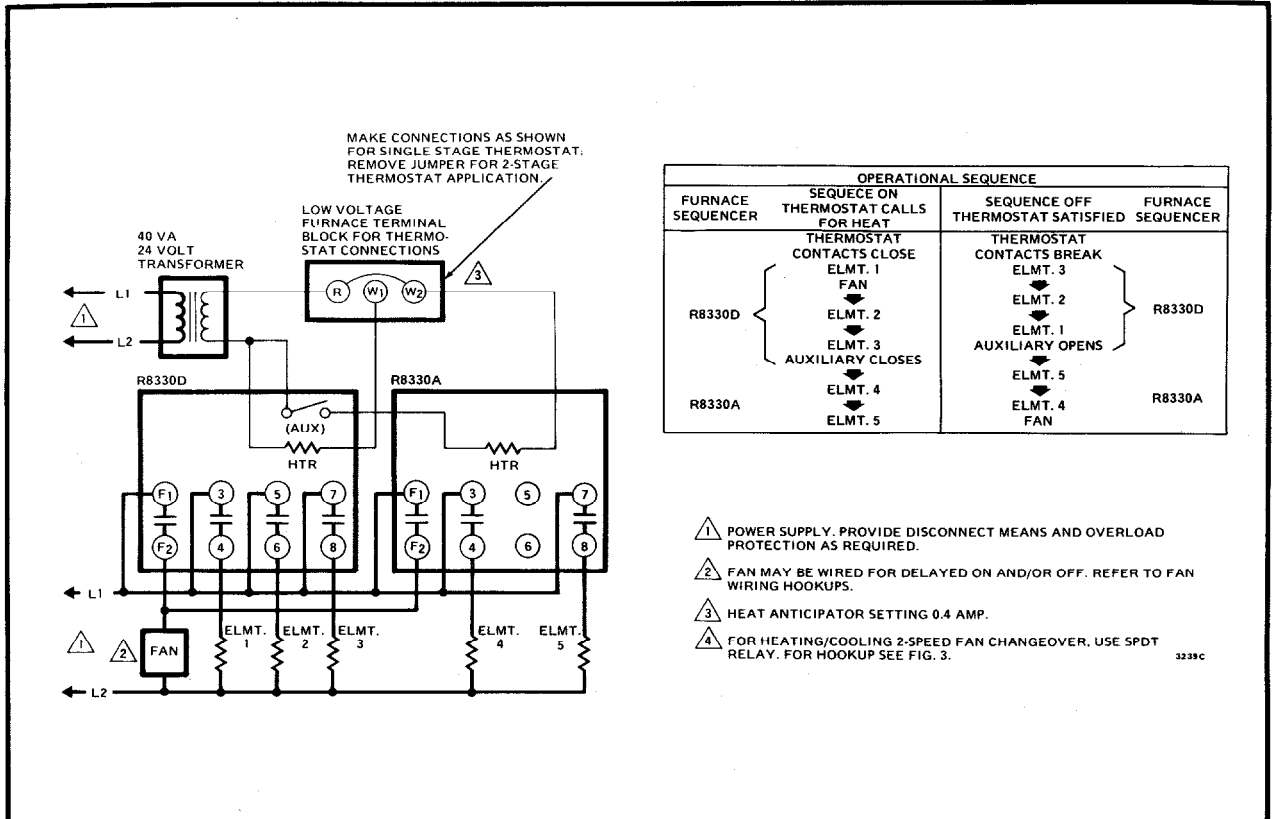


FIG. 13—WIRING SCHEMATIC FOR A FIVE-ELEMENT SYSTEM—ISOLATED FAN.

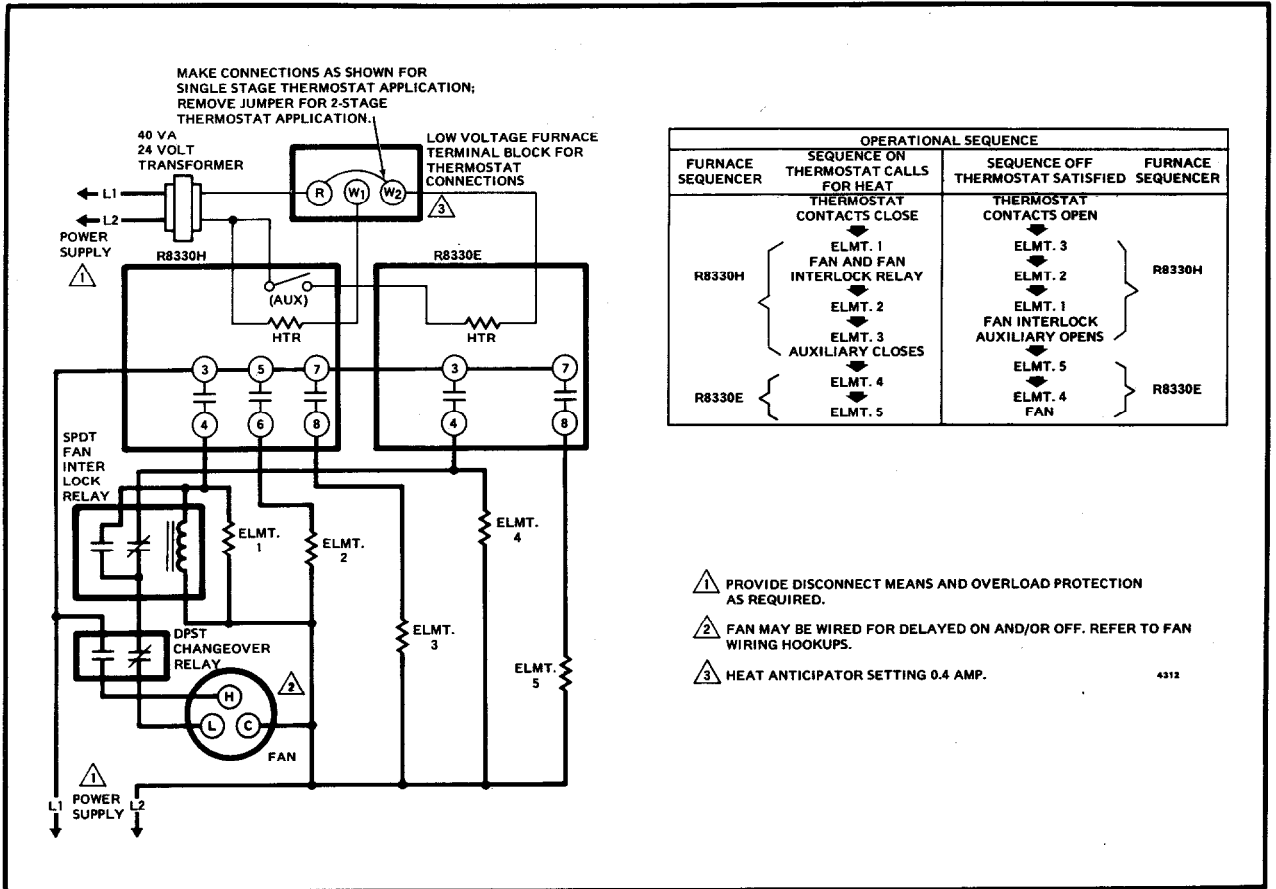


FIG. 14—WIRING SCHEMATIC FOR A FIVE-ELEMENT SYSTEM—COMBINATION RATED.

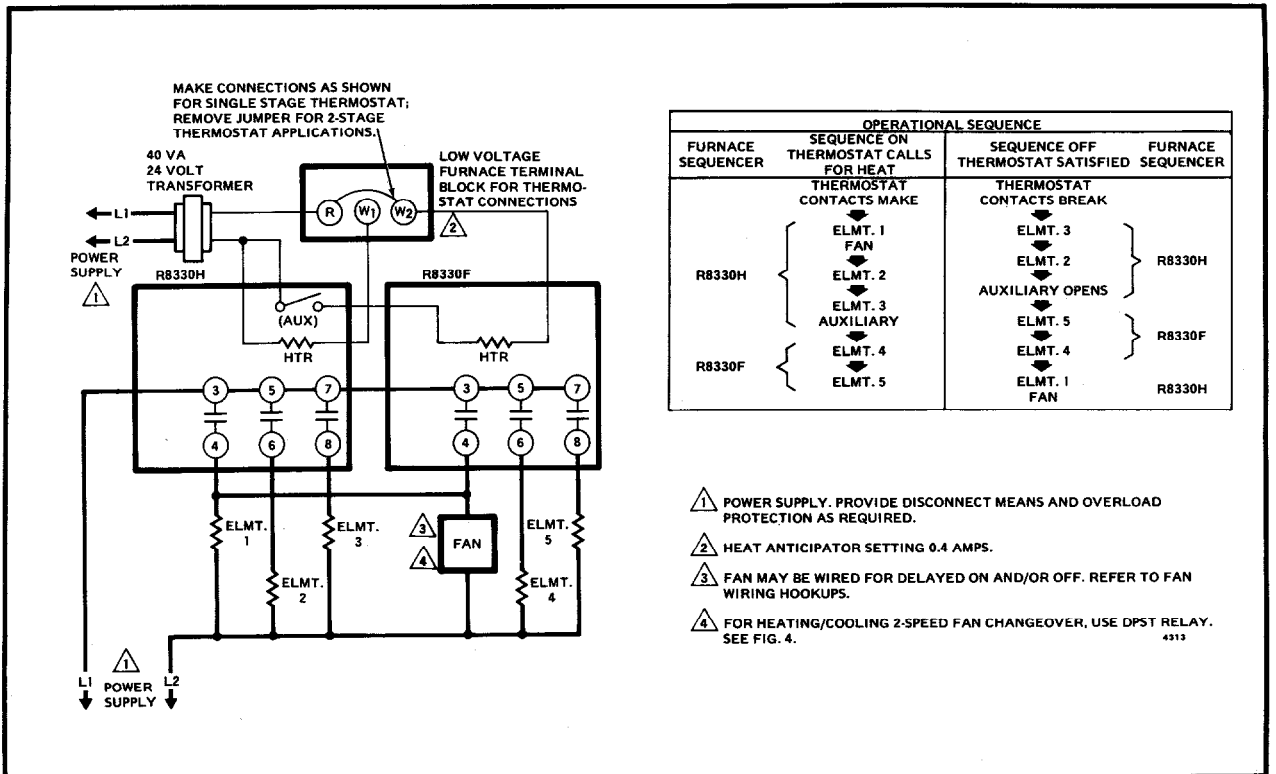
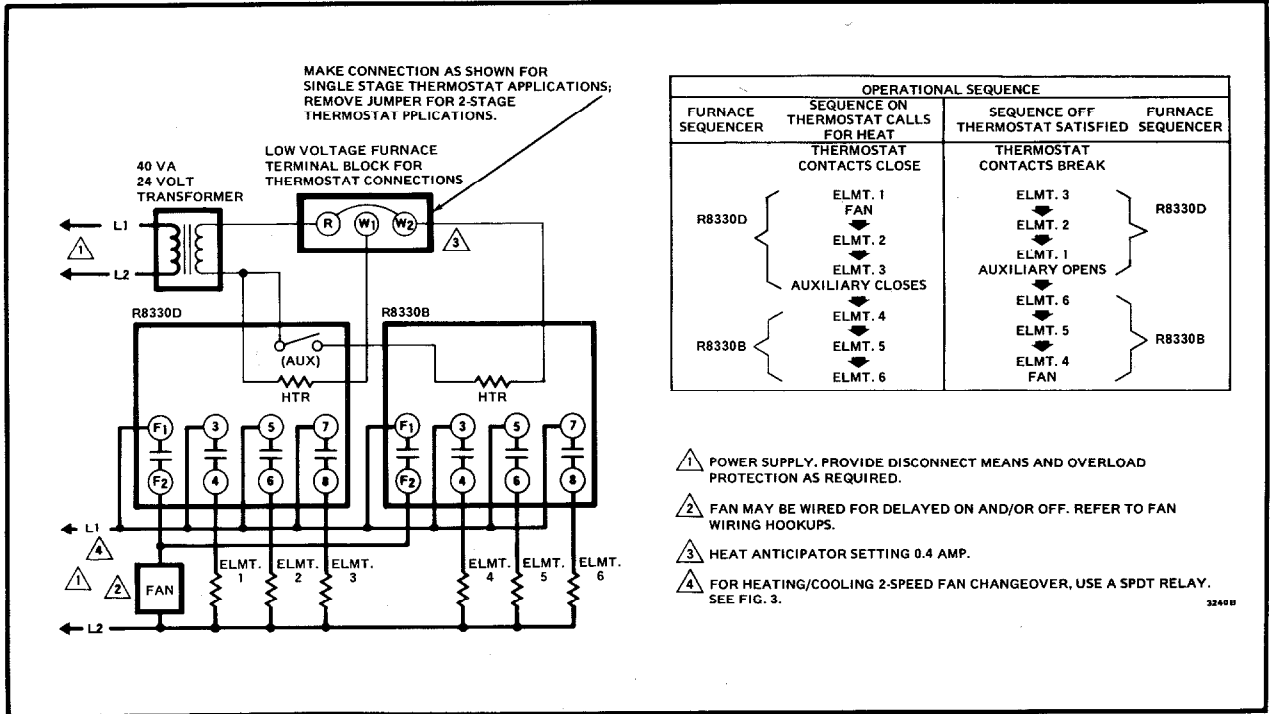
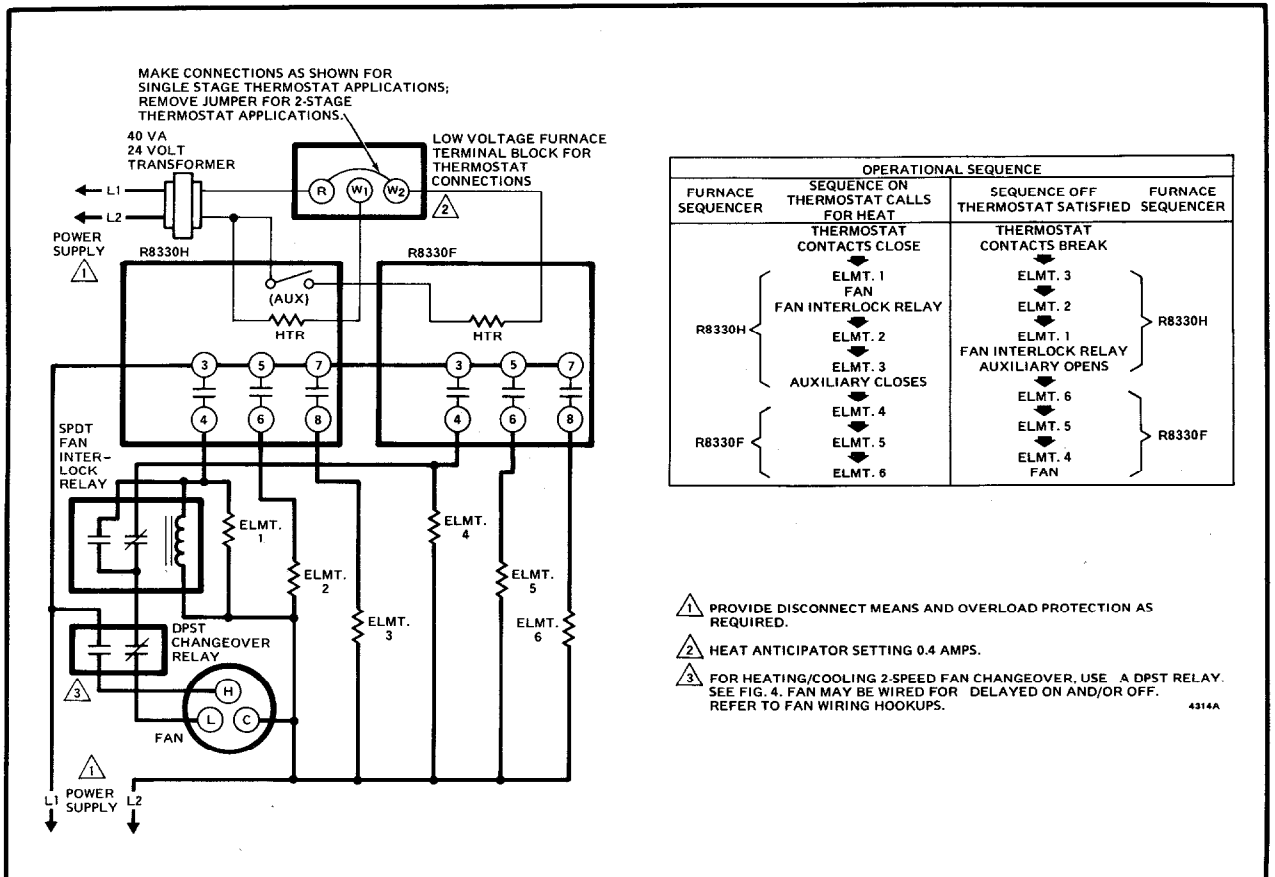


FIG. 15—WIRING SCHEMATIC FOR A FIVE-ELEMENT FURNACE—COMBINATION RATED.

## SIX-ELEMENT FURNACES

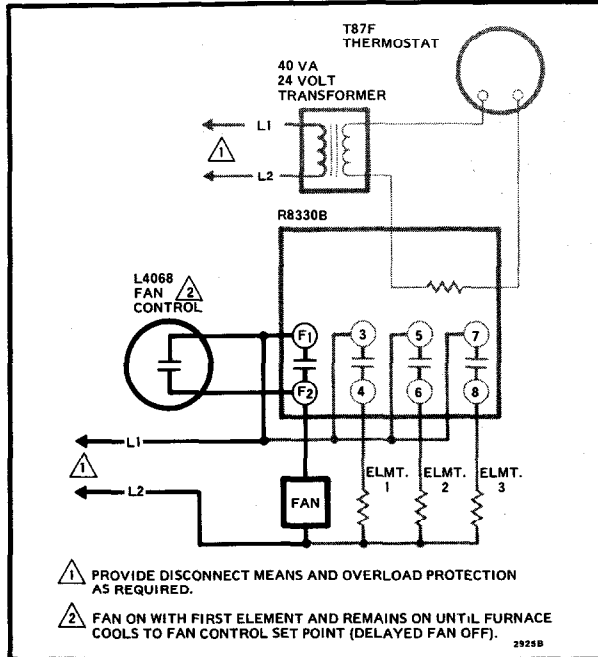


**FIG. 16—WIRING SCHEMATIC FOR A SIX-ELEMENT SYSTEM—ISOLATED FAN.**

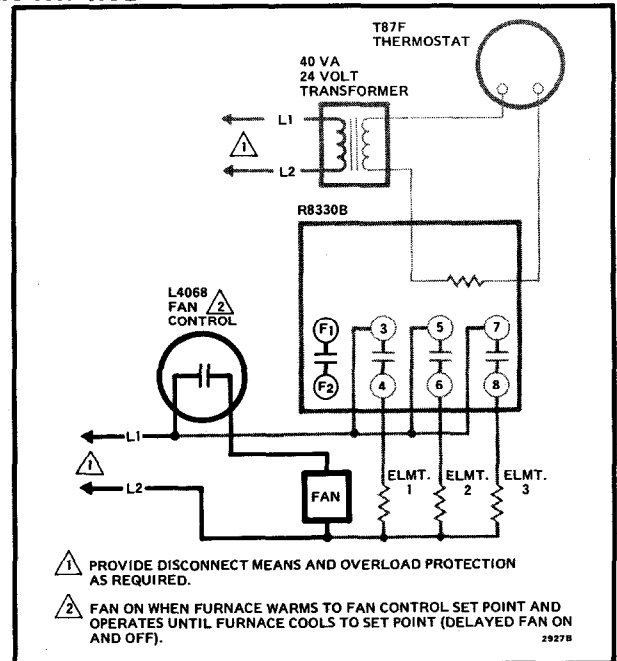


**FIG. 17—WIRING SCHEMATIC FOR A SIX-ELEMENT SYSTEM—COMBINATION RATED.**

## DELAYED FAN WIRING



**FIG. 18—WIRING SCHEMATIC FOR FAN DELAYED OFF. FAN COMES ON WITH FIRST ELEMENT AND REMAINS ON UNTIL FURNACE COOLS TO FAN CONTROL SET POINT.**



**FIG. 19—WIRING SCHEMATIC FOR FAN DELAYED ON AND OFF. FAN COMES ON WHEN FURNACE WARMS TO FAN CONTROL SET POINT AND OPERATES UNTIL FURNACE COOLS TO SET POINT.**

# CHECKOUT AND TROUBLESHOOTING

### CHECKOUT

Set the system thermostat to call for heat and make sure that all elements sequence on and off properly and that fan starts with first element on and stays on until all elements are off.

**NOTE:** This is a time delay device; allow time for elements to sequence on and off.

### SERVICE

The R8330 is not field repairable. If any component fails, it should be replaced. No adjustment or periodic service is required on these controls. Since all R8330's are very similar, the R8330D may be used to replace the R8330A-H or J.

### TROUBLESHOOTING

#### PRELIMINARY SYSTEM CHECKOUT

1. Check system wiring for any loose or broken connections.
2. Make sure that fan and all heating elements operate properly.

#### TRANSFORMER CHECKOUT

1. Use an ac voltmeter to measure the voltage across the secondary terminals. If voltage is 24V ac  $\pm$  10 percent, proceed to check the R8330. If incorrect, proceed to step 2.
2. Check that voltage across transformer primary is within  $\pm$  10 percent of rated voltage. If correct, replace the transformer. If the primary voltage is incorrect, correct source problems.

#### R8330 SYSTEM CHECKOUT

Refer to wiring diagrams. Note that if R8330 Sequencers are used in combination, the troubleshooting procedure must be adapted for the individual system.

1. Move the thermostat set point above the room temperature so that thermostat calls for heat—

- a. If system does not start (after time delay), proceed to step 2.
  - b. If fan and/or some heating elements start (but not all), proceed to step 3.
  - c. If fan and heating elements all sequence on properly, proceed to step 4.
2. Jumper RH to W1 at the thermostat—
    - a. If fan and heating elements now begin operating (after time delay), check thermostat and wiring and replace thermostat if necessary. Proceed to step 4.
    - b. If neither fan nor heating elements operate (and system wiring has been checked), replace the R8330.
  3. Jumper across the terminals of the inoperative fan or heating element. If the fan or element now starts, the contacts are not conducting; replace the R8330.

## WARNING

The R8330 contacts carry line voltage.

4. When all elements and fan are on, break the power supply to the R8330 by lowering the thermostat set point (or removing jumper RH-W1) so that switch breaks. Check to make sure that all heating stages sequence off, beginning with the last element on. The fan should operate until all stages are off, turning off with the last stage.

**NOTE:** This is a time delay device; allow time for all elements to sequence off.