



L8100A,B,C Aquastat® Controllers

PRODUCT DATA



- **Energy cutoff (ECO) switch enclosed in factory installed well of L8100A,B interrupts the thermocouple circuit or main valve before the tank reaches maximum temperature of 210°F (99°C).**
- **Internal adjustment screw.**
- **Immersion well is factory installed to the controller.**
- **Special switch terminal provides three-wire hookup from Aquastat® controller to gas valve.**
- **Four terminal models for manual reset with S86/VR8204/VR8440.**

SPECIFICATIONS

IMPORTANT

The specifications given in this publications do not include normal manufacturing tolerances. Therefore, an individual unit may not exactly match the listed specifications. Also, this product is tested and calibrated under closely controlled conditions, and some minor differences in performance can be expected when those conditions are changed.

Models:

- L8100A Aquastat® Controller. Regulates water temperature. Includes energy cutoff (ECO) switch that breaks controller circuit on a temperature rise above the setpoint.
- L8100B Aquastat® Controller. Regulates water temperature. Has a second sensing bulb that minimizes stacking by sensing the average tank temperature. Includes ECO switch which breaks controller circuit on a temperature rise above the setpoint.
- L8100C Aquastat® Controller. Regulates water temperature. Has a second sensing bulb that minimizes stacking by sensing the average tank temperature.

Electrical Ratings:

2A maximum at 24 Vac.

Differential:

Fixed, 5°F (3°C) for controller: 20°F (11°C) for ECO switch.

GENERAL

L8100A,B, and C are immersion type controllers for regulating and limiting the tank temperature in water heaters. As the water temperature rises past the setpoint, the controller switches off the gas valve.

FEATURES

- **L8100A regulates tank temperature and provides energy cutoff (ECO) action on a temperature rise past the setpoint.**
- **L8100B regulates temperature and provides ECO action on a temperature rise past the setpoint. This model includes a second sensing element that senses average water temperature to minimize stacking.**
- **L8100C includes a second sensing element that senses average water temperature to minimize stacking, but does not include ECO action.**
- **Fluid filled element operates single pole single throw (spst) snap-acting Micro Switch™.**

Contents

General	1
Features	1
Specifications	1
Installation	2
Operation and Checkout	7



Maximum Tank Temperature:
210°F (99°C).

Temperature Range:
L8100A: 100°F to 240°F (38°C to 116°C) with factory set stop to prevent setting above 160°F (71°C).
L8100B,C: 100°F to 180°F (38°C to 82°C).

Pressure Rating:
255 psi (1758 kPa).

Sensing Bulb:
Liquid (toluene) filled; 3/8 in. (10 mm) capsule.

Immersion Well:
1/2 in. (13 mm) or 3/4 in. (19 mm) NPT. See Fig. 2 for dimensions. All zinc plated except L8100B1094 and L8100B1185.

Capillary Length (for Remote Bulb):
24-5/8, 30, 39, 42, or 54 in. (625, 762, 991, 1067, or 1372 mm).

Insertion Depth:
See Fig. 2.

Insulation Depth:
See Fig. 2.

Finish:
Gray.

Dimensions:
See Fig. 1 for controller dimensions; see Fig. 2 for immersion well dimensions.

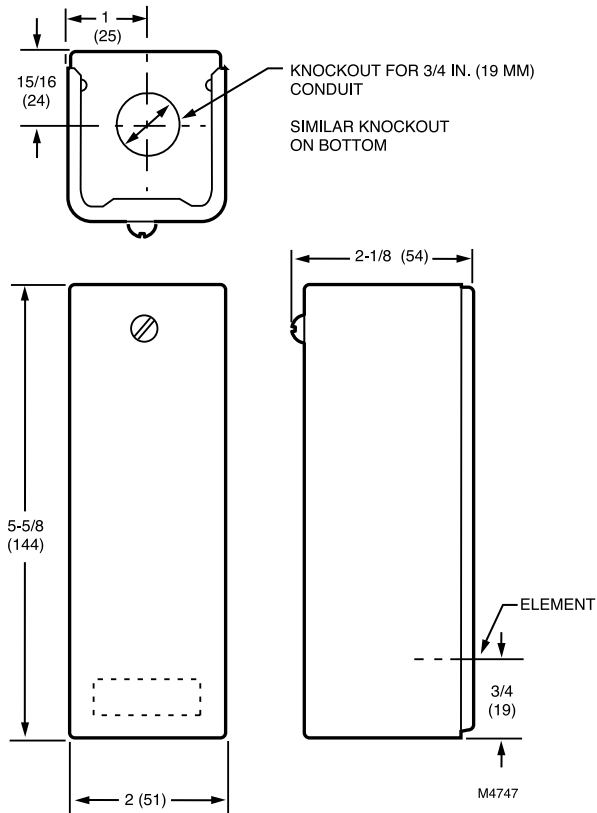
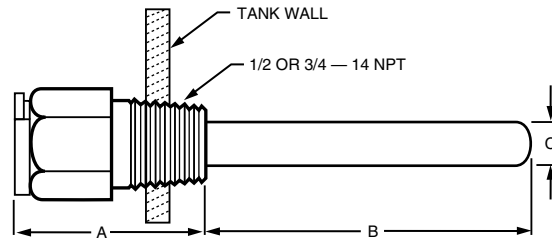

Fig. 1. Approximate dimensions of the L8100 Aquastat® Controller in in. (mm).

Available Options:
External adjustment screw and visible control point scale.
Factory set stop at 140°F (60°C).

Approvals:
Underwriters Laboratories Inc. Component Recognized:
File No. MP466, Guide Number MBPR2.
American Gas Association Design Certified:
Report Number 23-11B.

Part Available:
110641 Jumper to convert four-terminal L8100 to three-terminal L8100.



	CONTROLLER WELL		REMOTE WELL	
	IN.	MM	IN.	MM
A INSULATION DEPTH	2-1/4	57	1-1/2 OR 2-1/2	38 OR 64
B INSERTION DEPTH	5	127	3	76
C WELL DIAMETER	7/16	11	7/16	11

M4746

Fig. 2. Approximate dimensions for the controller immersion well and remote immersion well in in. (mm).

INSTALLATION

When Installing this Product...

1. Read instructions carefully. Failure to follow them could damage the product or cause a hazardous condition.
2. Check ratings and descriptions given in the specifications to make sure the product is suitable for your application.
3. Installer must be a trained, experienced service technician.
4. After installation is complete, check out product operation as provided in these instructions.



CAUTION

Electrical shock or equipment damage
Disconnect power before installation to prevent electrical shock or equipment damage.

Mounting Direct Immersion Well

The manufacturer usually provides a tapping for insertion of the controller sensing element. This tapping is located at a point where typical water temperature can be measured. Follow the instructions furnished by the system manufacturer, if available, or use the procedure below. See Fig. 3.

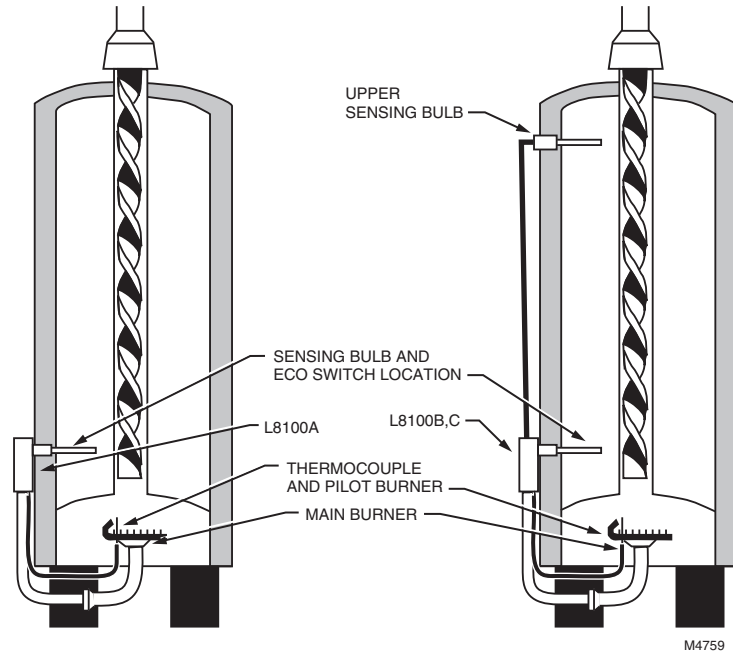

Fig. 3. Location of L8100A,B,C Aquastat® Controllers.

IMPORTANT

The controller immersion well is factory-installed to the controller. Do not remove the immersion well, this could damage the ECO switch.

1. If system is filled, drain to a point below the tapping.
2. Remove plug from tapping.
3. If tapping is suitable, carefully screw immersion well into tapping. Do not tighten or apply force to the controller case.
4. Fill tank. Make sure that well is screwed in tightly enough to prevent leakage.

4. Insert bulb into well, pushing tubing until bulb bottoms in well.
5. Attach mounting clamp end of well spud. Loosen draw nut and spread jaws of clamp with screwdriver if necessary.
6. With mounting clamp attached to well spud (make sure jaws of clamp hook over ridge at end of spud, as shown at points A in Fig. 4), adjust tubing to fit through mounting clamp groove, as shown at point B in Fig. 4.
7. Tighten draw nut until mounting clamp is firmly attached to well spud and tubing is held securely in place.

Mounting Remote Bulb (L8100B and L8100C)

The remote temperature sensing bulb is installed in an immersion well (Fig. 4) or located near a capillary compression fitting (Fig. 5) that extends into the upper portion of the tank to prevent stacking.

Immersion Well Fitting

The immersion well must snugly fit the sensing bulb for good thermal response. Install as follows:

1. Use tapping provided by tank manufacturer, if possible, or select an area where typical water temperature is best measured.
2. If tank is filled, drain to below point where bulb will be installed.
3. Screw well into tank.



CAUTION

Do not secure draw nut so tightly that mounting clamp collapses tubing.

Capillary Compression Fitting

1. Use tapping provided by manufacturer, if possible, or select an area where typical water temperature is best measured.
2. If tank is filled, drain to below point where bulb will be installed.
3. Screw fitting into boiler tank tapping.
4. Place packing nut on tubing.
5. Slide bulb completely through fitting.
6. Place composition disk and four slotted brass washers on tubing in order shown in Fig. 5. Turn brass washers so slots are 180 degrees apart.
7. Slide seal assembly into fitting and tighten packing nut.

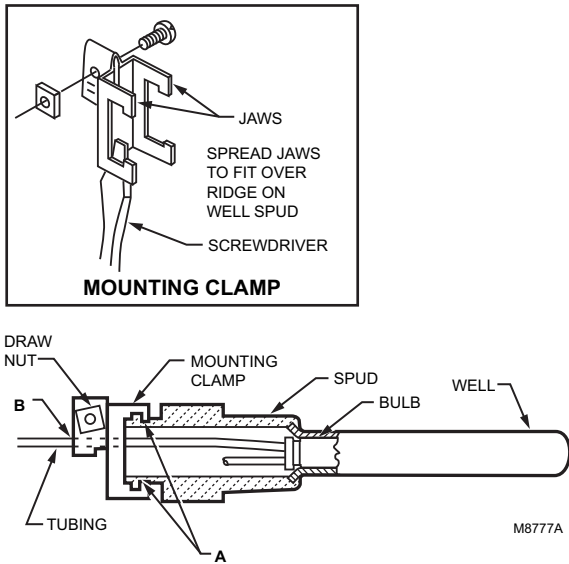

Fig. 4. Immersion well fitting for L8100 remote bulb.

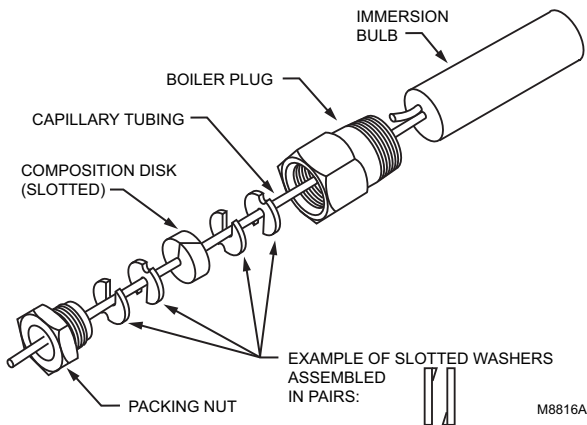

Fig. 5. Capillary compression fitting for L8100 remote bulb.

WIRING

Disconnect power supply before installation to prevent electrical shock or equipment damage. All wiring must comply with local codes and ordinances regarding wire size, type of insulation, enclosure, etc. Fig. 6 through 11 show typical Powerpile® (millivolt) gas control connections; Fig. 12 and 13 show typical connections for 24 Vac systems; Fig. 14 through 16 show an L8100 hookup with an S86E,F,G, or H Intermittent Pilot System.

Some four-terminal models are shipped with jumper in place for use as three-terminal models. Remove jumper for four-terminal operation.

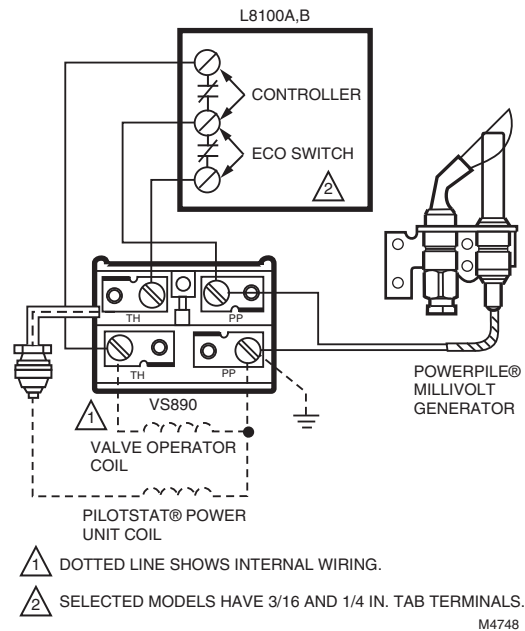

Fig. 6. L8100A,B hookup with VS890 where controller cuts out main valve and ECO switch cuts out pilot safety valve.

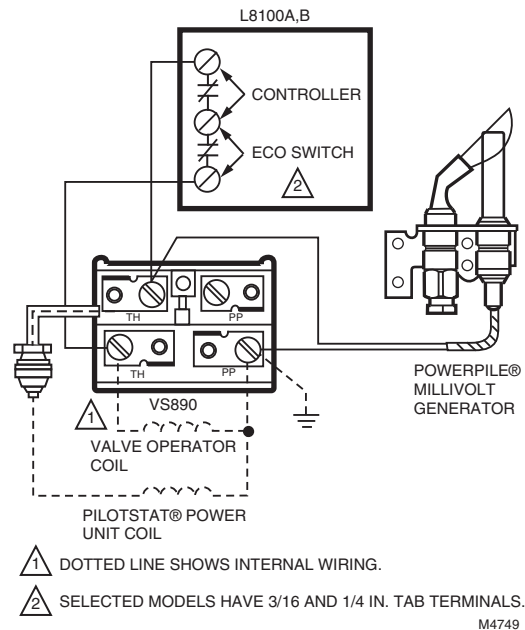

Fig. 7. L8100A,B hookup with VS890 where controller and ECO switch are placed in series to cut out main valve.

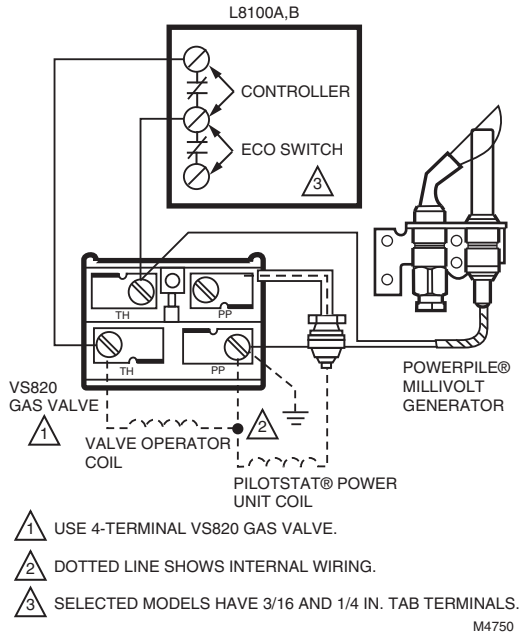

Fig. 8. L8100A,B hookup with four-terminal VS820 where controller cuts out main valve and ECO switch cuts out pilot safety valve.

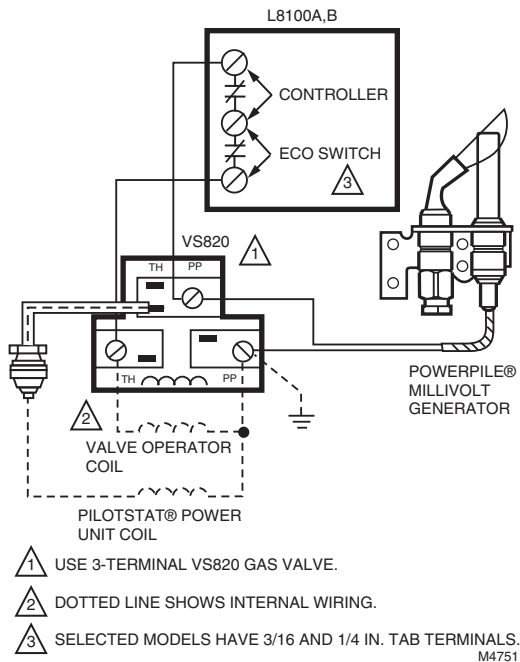

Fig. 9. L8100A,B hookup with three-terminal VS820 where controller and ECO switch are placed in series to cut out main valve.

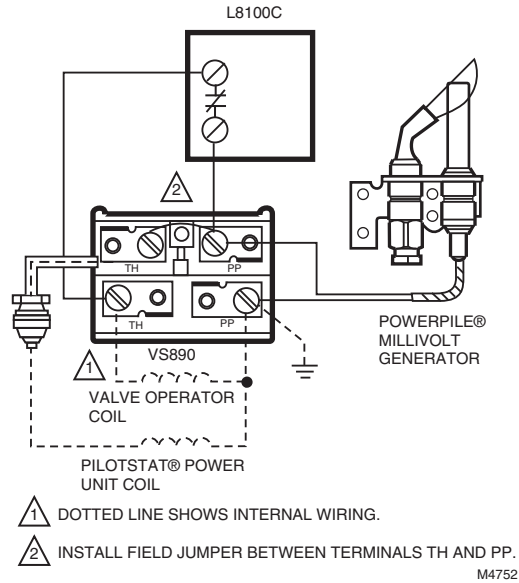

Fig. 10. L8100C hookup with VS890 to cut out main valve.

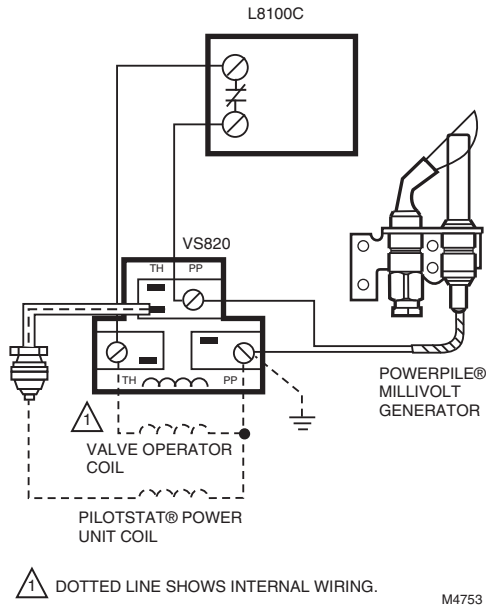

Fig. 11. L8100C hookup with three-terminal VS820 to cut out main gas valve.

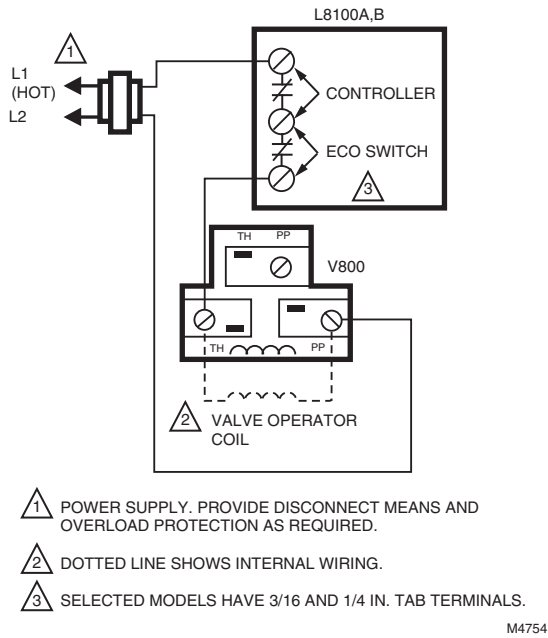

Fig. 12. L8100A, B hookup with V800 to cut out main valve.

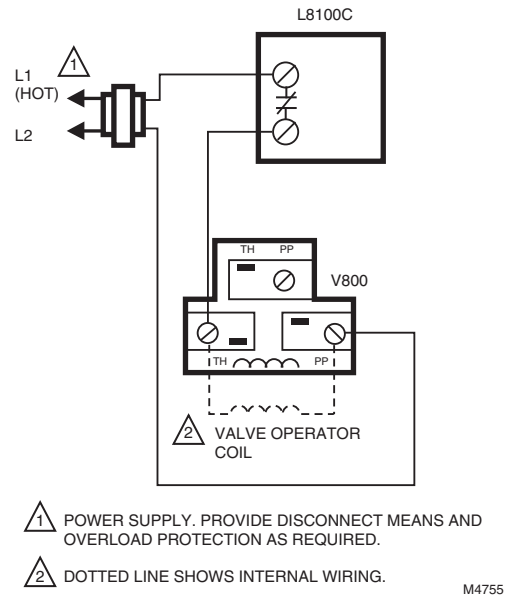

Fig. 13. L8100C hookup with V800 to cut out main valve.

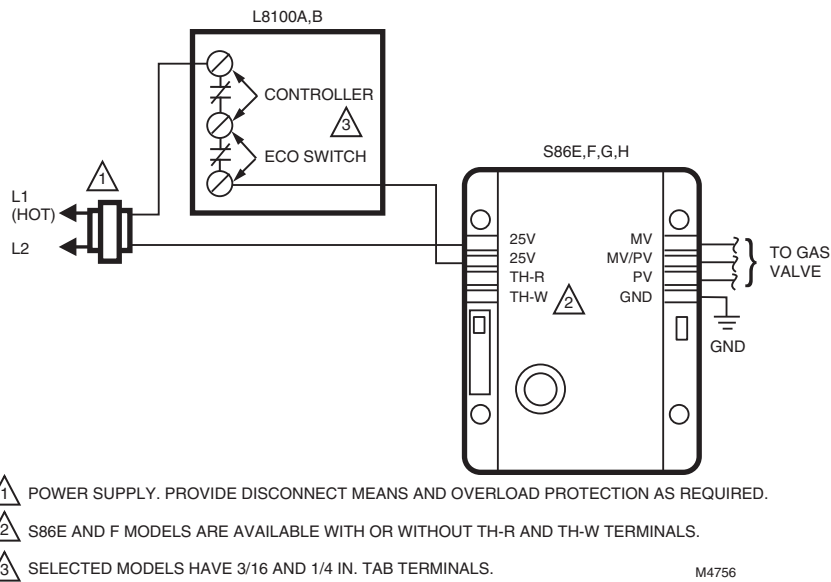

Fig. 14. Three-terminal L8100A,B hookup with S86E,F,G,H intermittent pilot system.

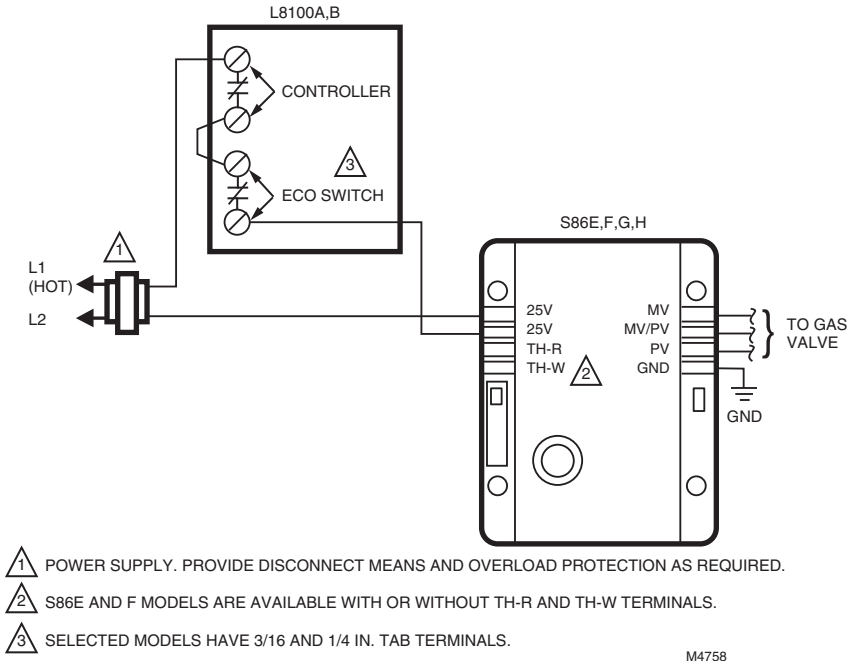

Fig. 15. Four-terminal L8100A,B hookup with S86E,F,G,H intermittent pilot system.

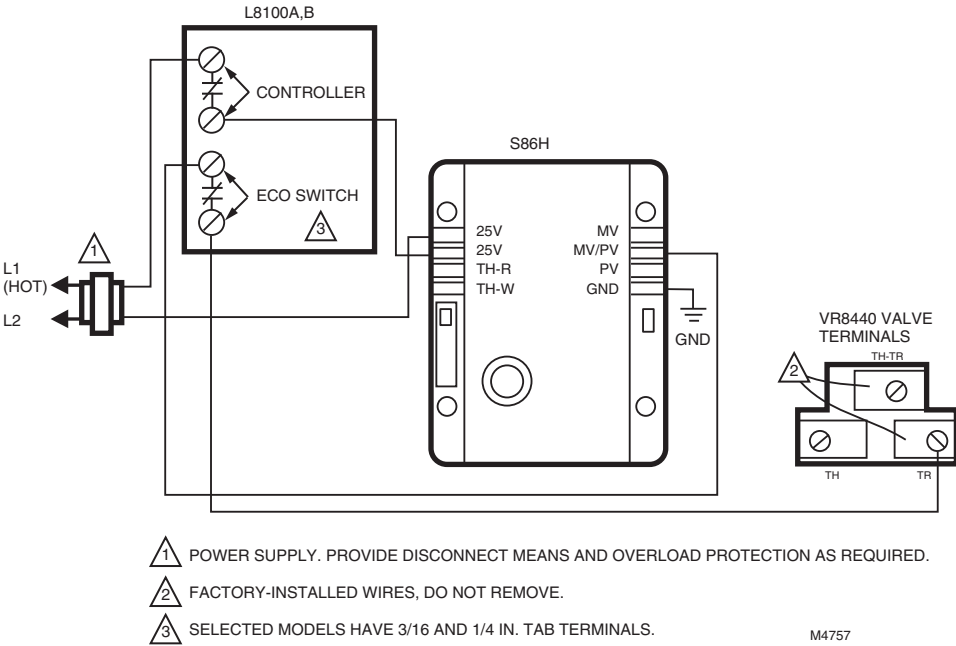

Fig. 16. Four-terminal L8100B manual reset hookup with S86H and VR8440.

OPERATION AND CHECKOUT

Operation

When tank temperature rises past the setpoint, the liquid fill in the sensing element expands and activates the snap-acting switch, closing the gas valve. When the water

temperature drops below the differential, the switch opens the gas valve and the burner begins heating the water. The ECO switch will break the circuit to the Powerpile® millivolt generator or 24 Vac main valve before the water temperature rises to 210°F (99°C).

The second element of the L8100B,C is located at the top of the tank. These two elements sense the average temperature in the tank. If a stacking condition begins, the L8100B,C will close the valve before the top tank temperature becomes excessive.

Adjusting

Adjust the control point to agree with the manufacturer's recommendations. To adjust, remove the cover and set the scale to the desired control point (see Fig. 17).

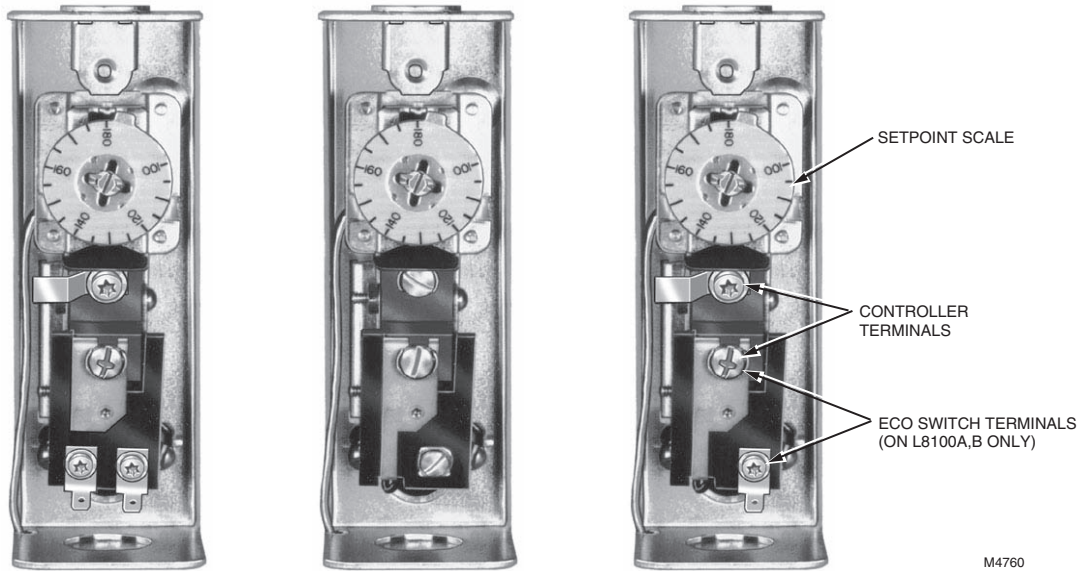

Fig. 17. Internal view of the L8100.

CHECKOUT

Check to verify the Aquastat® controller was installed and adjusted properly. Put the system into operation and observe the action of the device through several cycles to make certain that it provides proper control of the system. Further adjustments can then be made to meet more exact comfort requirements.



www.resideo.com

Resideo Technologies, Inc.
1985 Douglas Drive North, Golden Valley, MN 55422
1-800-468-1502
60-2336-04 M.S. Rev. 05-20 | Printed in United States