

DS06D,G Dial Set Pressure Regulating Valve

PRODUCT DATA



FEATURES

- Built-in, factory-calibrated outlet pressure adjustment dial.
- Noncorroding unitized cartridge contains all working parts and is easily replaceable.
- Outlet pressure range from 15 to 130 psi in all models, inlet rating 400 psi.
- Includes built-in strainer and thermal bypass.
- Narrow design to accommodate restricted installation requirements.
- Balanced seat construction provides superior pressure regulation.
- Inlet and outlet are internally threaded NPT, and externally threaded for use with union assemblies.
- Gauge taps provided on all models.

APPLICATION

The Honeywell DS06D,G Dial Set is a high quality pressure regulating valve that maintains a constant outlet pressure over a wide range of inlet supply pressures. It is ideally suited for potable water and irrigation applications requiring accurate regulation.

The wide outlet pressure range, high inlet pressure, and compact design allow flexibility in installation and application.

To facilitate setup and checkout, the DS06D,G features a calibrated outlet pressure set dial that allows outlet pressure adjustments without the use of a gauge in most applications.

Contents

Application/Features	1
Specifications/Ordering Information	2
Installation	3
Maintenance and Repair	4
Operation/Troubleshooting	6
DS06D,G Parts and Accessories	7



SPECIFICATIONS

Model: DS06D,G Dial Set Pressure Regulating Valve.

Construction Materials:

- Body: Bronze.
- Internal Parts: Stainless steel, NBR, and engineered plastics.
- Regulator Mechanism: Fabric reinforced diaphragm.

Thermal Bypass Relief: Integral thermal bypass relief mechanism on all models.

Seat Design: Balanced single seat.

Inlet Pressure (Maximum): 400 psi.

Reduced Pressure Range: 15 to 130 psi (all models).

Outlet Pressure: Factory set at 60 psi.

Dial Calibration: ±4 psi.

Differential: 14 psi minimum (for optimum regulation).

Reduced Ratio: 10:1 maximum.

Temperature (Maximum): 180° F (82° C).

Ambient Temperature Range: 33° F to 140° F (1° C to 60° C).

Pipe Sizes Available: 1-1/2 and 2 in.

Connections: All models have internal NPT on inlet and outlet and external union connection on inlet and outlet. Single and Double Union Sweat and Thread models.

Strainer Screen Size: 0.040 in. (1.0 mm), equivalent to 18 mesh.

Gauge Taps: 1/4 in. NPT (two, one on each side of body).

Weight (With One Union):

- 1-1/2 in. is 7.7 lb (3.5 kg).
- 2 in. is 8.5 lb (3.9 kg).

Approvals:

ASSE 1003, City of LA, CSA, IAPMO.

Dimensions: See Fig. 1.

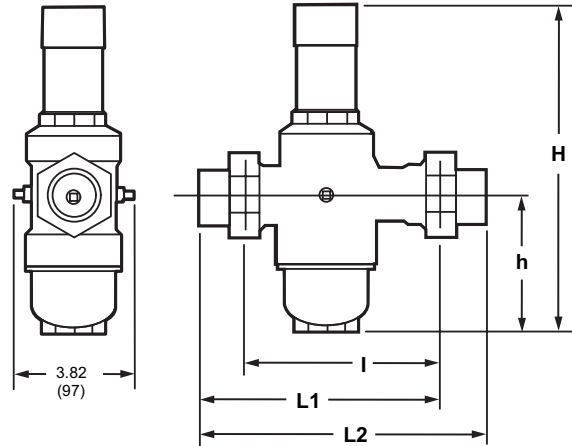

SIZE	DIMENSIONS IN IN. (MM)		THREADED		SWEAT		
	H	h	I	L1	L2	L1	L2
1-1/2	11-13/16 (299)	5 (126)	6-3/8 (163)	7-13/16 (198)	9-3/16 (234)	7-7/8 (201)	9-3/8 (239)
2	11-13/16 (299)	5 (126)	6-3/8 (163)	7-7/8 (200)	9-5/16 (237)	8-5/16 (211)	10-3/16 (259)

M11203

Fig. 1. DS06D,G Installation Dimensions in inches (mm).

ORDERING INFORMATION

When purchasing replacement and modernization products from your TRADELINE® wholesaler or distributor, refer to the TRADELINE® Catalog or price sheets for complete ordering number.

If you have additional questions, need further information, or would like to comment on our products or services, please write or phone:

1. Your local Honeywell Automation and Control Products Sales Office (check white pages of your phone directory).
2. Honeywell Customer Care
1885 Douglas Drive North
Minneapolis, Minnesota 55422-4386

In Canada—Honeywell Limited/Honeywell Limitée, 35 Dynamic Drive, Toronto, Ontario M1V 4Z9.

International Sales and Service Offices in all principal cities of the world. Manufacturing in Australia, Canada, Finland, France, Germany, Japan, Mexico, Netherlands, Spain, Taiwan, United Kingdom, U.S.A.

Water Capacities (See Table 1)

The suitability of a given regulator size is dependent on the pressure requirements of each installation. To determine the pressure regulator valve size required for a specific installation, calculate the following:

1. Pressure differential between inlet and outlet pressure in pounds per square inch (psi).
2. Capacity in gallons per minute (gpm), and
3. Allowable reduced pressure falloff in psi.

Given these variables, use Table 1 to determine the proper size pressure regulator valve for your application.

Example: An installation has 135 psi inlet pressure, 60 psi outlet pressure (75 psi pressure differential). If 30 gpm capacity is required with only 10 psi falloff allowable, a 1-1/2 in. DS06D,G is required. This pressure regulator valve allows a flow capacity up to 46 gpm with a 10 psi falloff at a no flow pressure differential of 75 psi.

Table 1. Water Capacities.

Size (in.)	Reduced Pressure Fall off in psi	Pressure Differential Between Inlet and Outlet (psi)—No Flow							
		25		50		75		100	
		Flow Capacity in US gpm	Velocity in ft/sec	Flow Capacity in US gpm	Velocity in ft/sec	Flow Capacity in US gpm	Velocity in ft/sec	Flow Capacity in US gpm	Velocity in ft/sec
1-1/2	6	13	2.0	15	2.4	17	2.7	21	3.3
	10	36	5.7	43	6.8	46	7.2	54	8.5
	15	65	10.2	76	12.0	84	13.2	96	15.1
	20	88	13.9	102	16.1	114	18.0	132	20.8
2	6	15	1.4	18	1.7	22	2.1	27	2.6
	10	41	3.9	49	4.7	57	5.4	66	6.3
	15	75	7.2	88	8.4	101	9.7	114	10.9
	20	104	9.9	124	11.9	141	13.5	163	15.6

INSTALLATION

When Installing This Product...

1. Read these instructions carefully. Failure to follow them could damage the product or cause a hazardous condition.
2. Check the ratings given in these instructions and on the product to make sure the product is suitable for your application.
3. Installer must be a trained, experienced service technician.
4. After installation is complete, check out the product as provided in these instructions.

Procedure

1. Flush the system clear of sediment and debris.
2. Close the supply valve and downstream isolating valve (if existing).
3. Install the DS06D,G with the arrow pointing in the direction of water flow (any mounting orientation is acceptable). The DS06D,G can be installed directly onto a pipe using the female NPT threads on each end or by using single or double unions, if required. (One union is provided.)

CAUTION

Heat from soldering can damage internal parts. Always remove tailpiece or solder adapter prior to soldering.

4. Open the supply valve slowly and open the downstream valve, if provided.
5. Check for leaks at connections and correct, if necessary.

Adjusting Outlet Pressure (See Fig. 2)

The DS06D,G is factory set at 60 psi (no flow). Follow this procedure if adjustment is required:

1. Remove dust cap and loosen locking screw one turn counterclockwise. Do not remove the locking screw.
2. Turn adjusting knob clockwise to increase pressure and counterclockwise to decrease pressure. When decreasing pressure, a slight downstream flow is necessary to relieve pressure. Turn until dial scale indicates desired pressure (no flow set pressure).
3. Tighten locking screw and replace dust cap.

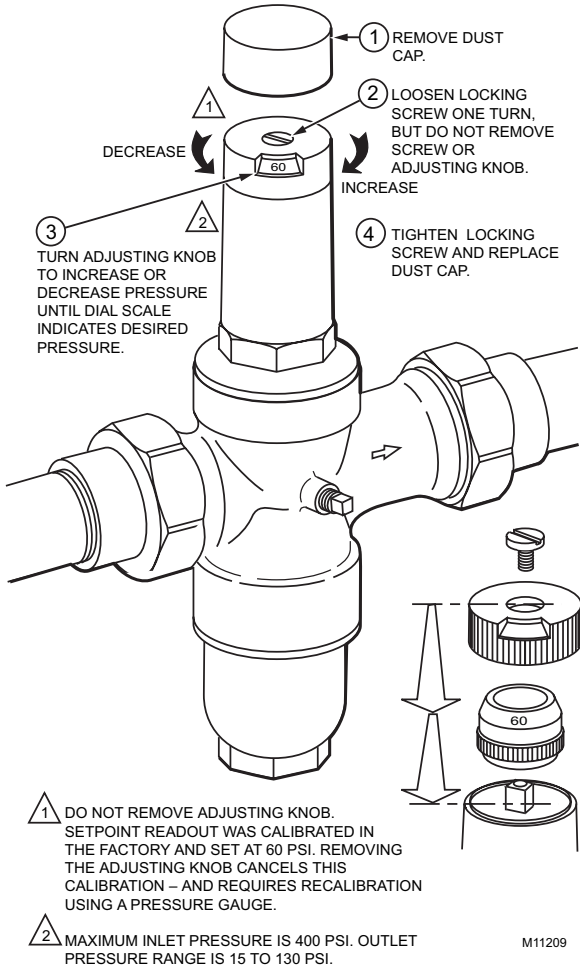

Fig. 2. Adjusting Outlet Pressure

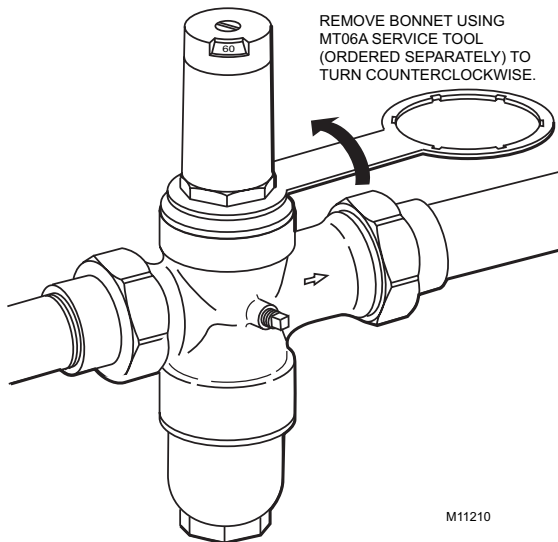

Fig. 3. Removing Bonnet.

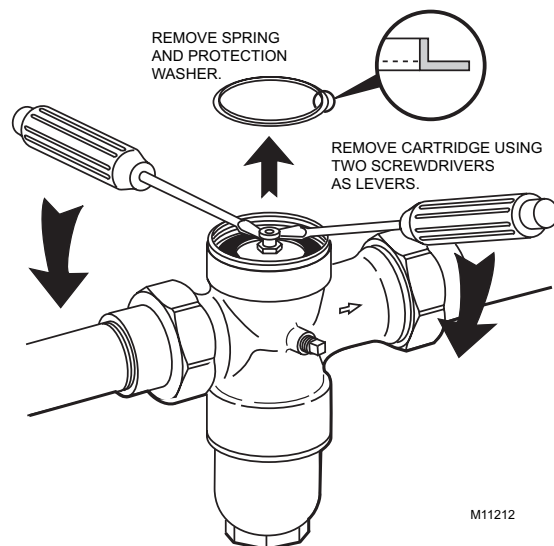

Fig. 4. Removing Cartridge.

MAINTENANCE AND REPAIR

Replacing DS06D,G Cartridge

The working parts of the DS06D,G, including diaphragm, valve seat, strainer, and disk, are all contained in a replaceable cartridge. To replace the cartridge:

1. Close the supply valve and relieve the downstream pressure.
2. Remove the dust cap. Relieve pressure on the spring by loosening the locking screw (do not remove) and turning the adjusting knob counterclockwise until no resistance is felt.
3. Remove the bonnet (See Fig. 3) by turning counterclockwise. Remove the spring and protection washer (See Fig. 4).
4. Remove the cartridge using two screwdrivers as levers (See Fig. 4). Remove the cartridge O-ring.
5. Remove the strainer cup (See Fig. 5).
6. Remove the strainer and strainer support. Remove the U-seal.
7. Clean the inside of the valve and all the components.

NOTE: Replace the U seal (provided in the repair kit) for a complete cartridge repair.

8. Replace the U-seal by placing the U-seal on the strainer support and pushing the assembly into place. The U-seal open end must face the strainer support (See Fig. 7). Replace the strainer onto the strainer support.
9. Assemble the strainer cup O-ring onto the strainer cup and insert the assembly into the body of the valve. Tighten securely using the service tool. Do not over torque.
10. Replace the new cartridge ensuring the O-ring is in place.
11. Replace the protection washer with the lip up (away from the valve body). See Fig. 6.
12. Replace the spring and bonnet. Tighten the bonnet using the service tool. Do not over torque.
13. Adjust the outlet pressure following the procedure in Adjusting the Outlet Pressure section.

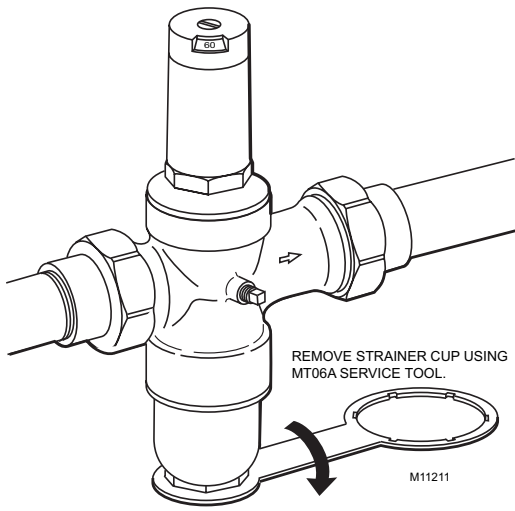

Fig. 5. Removing Strainer Cup.

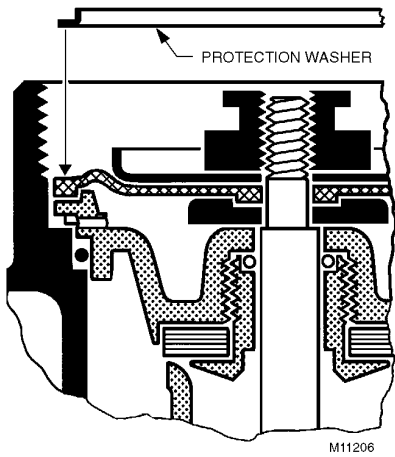

Fig. 6. Replacing Protection Washer.

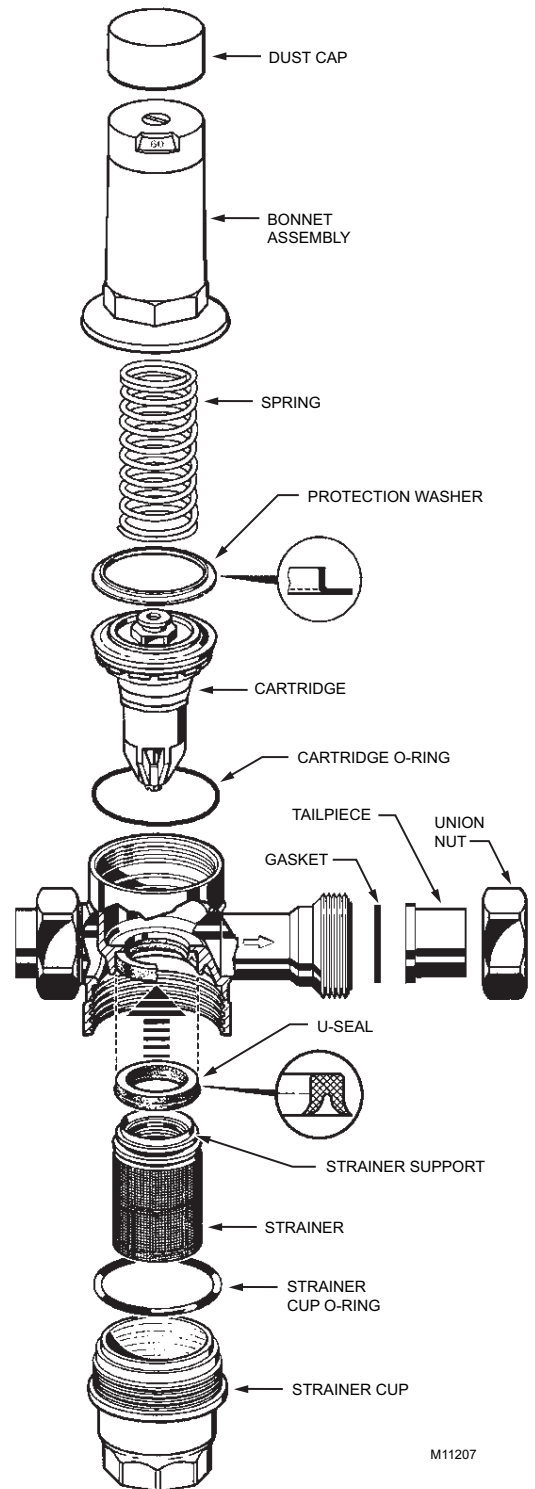

Fig. 7. Internal Parts.

Cleaning Strainer Screen

To clean the strainer screen:

1. Close the supply valve and relieve the downstream pressure.
2. Remove the strainer cup (See Fig. 5).
3. Remove the strainer and the strainer support. Do not remove the U-seal.
4. Clean the strainer cup and the strainer.
5. Replace the strainer on the strainer support. Insert the assembly into the valve.
6. Assemble the strainer cup O-ring onto the strainer cup and insert the assembly into the body of the valve. Tighten securely using the service tool. Do not over torque.

Recalibrating DS06D,G

If the adjusting knob and dial are accidentally removed, the dial must be recalibrated as follows:

1. Follow the procedure in Adjusting the Outlet Pressure section. Set the pressure on the gauge at 60 psi (or another convenient pressure).
2. Reassemble the dial ring onto the bonnet with the pressure on the ring matching the pressure gauge.
3. Assemble the locking screw and tighten. Replace the dust cap.

OPERATION

The Honeywell DS06D,G Dial Set is a balanced, direct acting pressure-regulating valve. It provides constant downstream pressure regardless of varying inlet pressures and downstream flow demands.

The spring force holds the valve in the open position until downstream pressure, sensed by a port, is sufficient to press on the underside of the diaphragm and close the valve. As downstream pressure drops due to demand, the force on the diaphragm is reduced and the valve opens. Adjustment is made by manually turning the adjustment knob clockwise to increase the spring force and require a higher downstream pressure to close the valve. Similarly, reducing the spring force lowers the outlet set pressure. A factory-calibrated dial is built into the adjustment mechanism to allow outlet pressure (under no flow condition) to be set without a gauge. A lock screw maintains the setting. A black plastic cover is provided for additional protection.

When the outlet pressure is set, the DS06D,G automatically regulates to maintain the downstream pressure.

TROUBLESHOOTING

Table 2 is a troubleshooting guide for the DS06D,G Pressure Regulating Valves.

Table 2. Troubleshooting DS06D,G Pressure Regulating Valves.

Problem	Cause	Solution
Will not hold pressure or pressure gradually rises.	Thermal expansion. Debris on valve seat. Damaged valve seat.	Install a thermal expansion tank to limit pressure rise. Clean valve. Replace cartridge.
Frozen.	Valve exposed to freezing temperatures below 32° F (0° C).	Inspect and replace any damaged components. Move valve to a location that remains above freezing.
Pressure gauge measures a lower pressure under flow conditions than set pressure at no flow.	This is normal and characteristic of direct-acting pressure-reducing valves.	No action is necessary.
Low capacity, low outlet pressure.	Screen blocked with debris. Valve undersized.	Clean screen. Check capacity versus requirements and increase valve size.

DS06D,G PARTS AND ACCESSORIES

Product Number Description

Replacement Parts

K06B1030	Strainer Kit for D06G and DS06G, 1-1/2 in. and 2 in., includes strainer, strainer support, and strainer cup O-ring.
K06D1044	Cartridge Kit for all D06 and DS06, 1-1/2 in. and 2 in., includes cartridge, cartridge O-ring, strainer cup O-ring, U-seal, and protection washer.
272852	Strainer Cup for D06G and DS06D,G, 1-1/2 in. and 2 in., includes plastic strainer cup and strainer cup O-ring.
272867	Bonnet kit for D06G, 1-1/2 in. and 2 in., includes preassembled bonnet, protection washer, and spring.

Union Kits

K06U5034	Union Kit Sweat, 1-1/2 in., includes sweat tailpiece, union nut, and gasket, and fits all 1-1/2 in. D06 and DS06 Valves.
K06U5042	Union Kit Sweat, 2 in., includes sweat tailpiece, union nut, and gasket, and fits all 2 in. D06 and DS06 Valves.

Automation and Control Solutions

Honeywell International Inc.
1985 Douglas Drive North
Golden Valley, MN 55422
customer.honeywell.com

Honeywell Limited-Honeywell Limitée
35 Dynamic Drive
Toronto, Ontario M1V 4Z9

® U.S. Registered Trademark
© 2006 Honeywell International Inc.
62-3052—1 J.I. Rev. 11-06



Printed in U.S.A. on recycled
paper containing at least 10%
post-consumer paper fibers.

Honeywell