

This is a legacy product document supported by Resideo. It is no longer manufactured

UV100E Ultraviolet Air Treatment System

enviracaire
ELITE™

whole-house air quality system

PRODUCT DATA



APPLICATION

When installed in forced air heating and cooling systems, the UV100E Ultraviolet Air Treatment System kills airborne and surface micro-organism contaminants.

FEATURES

- UV-C light kills airborne and surface bacteria.
- Continuously emits ultraviolet energy.
- UV lamp does not produce ozone.
- Sealed unit design prevents accidental installer and homeowner contact with the voltage and with the ultraviolet rays.
- Safe design prevents lamps from lighting unless the base is correctly mounted on the HVAC duct.
- Light pipe to safely view the lamp operation.
- Power cord that plugs into 120 Vac electrical outlet.
- Quick and easy lamp replacement.
- Easy lamp maintenance.
- AIRWATCH™ Indicator can be installed to remind customers when to change lamp.
- To capture and minimize micro-organism pass-through in residential heating, ventilation and air conditioning (HVAC) systems, combine the Ultraviolet Air Treatment System with a high-efficiency air filtration system that includes an electronic air cleaner.
- Bold Enviraire Elite look with blue and white styling.
- Five-year limited warranty.



SPECIFICATIONS

IMPORTANT

The specifications in this publication do not include normal manufacturing tolerances; therefore, an individual unit may not exactly match the listed specifications. This product is tested and calibrated under closely controlled conditions and some minor differences in performance can be expected if those conditions are changed.

TRADELINE® Models available:

The UV100A Ultraviolet Air Treatment System is available in three models: a single-lamp, moderate-efficiency return air unit; a dual-lamp, high-efficiency return air unit; and an air conditioner coil irradiation unit.

- UV100E single-lamp unit is mounted in the return air duct of an HVAC system. It has moderate-efficiency performance against airborne bacteria in return air applications.
- UV100E dual-lamp unit is mounted in the return air duct of an HVAC system. It has high-efficiency performance against airborne bacteria in return air applications.
- UV100E coil irradiation unit is mounted downstream from the air conditioner cooling coils or in the return air duct of the HVAC system. The single-lamp unit reduces mold growth and spores on duct surfaces, coils and drip pans.

Efficiencies:

- UV100E Coil Irradiation unit: Kills up to 99.9% of mold on system cooling coils.
 - Test performed in a test duct showed reduction in colony-forming aspergillus niger mold spores when surface was irradiated at a distance of 18 in. for three hours in still air, using new lamps.

- UV100A Dual-Lamp unit: Kills up to 87% of airborne bacterial passing by the system.
 - Test showed single-pass kill-rate of serratia marcescens bacteria in a clean metal 12 in. x 25 in. duct at an airflow rate of 2000 cfm using new lamps.
- UV100A Single-Lamp unit: Kills up to 70% of airborne bacteria passing by the system.
 - Test showed single-pass kill-rate of serratia marcescens bacteria in a clean metal 12 in. x 25 in. duct at an airflow rate of 2000 cfm using new lamps.

Approvals:

Underwriters Laboratories: File no. E212213.

The health aspects associated with the use of this product and its ability to aid in disinfection of environmental air have not been investigated by UL.

Electrical Ratings:

Power Rating: 120 Vac, 60 Hz.

Consumption:

Model	Input Power (A)	Lamp Wattage (W)
Coil Irradiation	0.85	36
Single-Lamp Return	0.4	18
Dual-lamp Return	0.7	36 each lamp

Temperature Ratings:

Ambient Temperature Range: 30°F to 104°F (-2°C to 40°C).

Lamp Temperature Range: 30°F to 104°F (-2°C to 40°C).

Relative Humidity:

Up to 95% rh, non-condensing.

Dimensions:

See Fig. 2.

ORDERING INFORMATION

When purchasing replacement and modernization products from your TRADELINE® wholesaler or distributor, refer to the TRADELINE® Catalog or price sheets for complete ordering number.

If you have additional questions, need further information, or would like to comment on our products or services, please write or phone:

1. Your local Home and Building Control Sales Office (check white pages of your phone directory).
2. Home and Building Control Customer Relations
Honeywell, 1885 Douglas Drive North
Minneapolis, Minnesota 55422-4386

In Canada—Honeywell Limited/Honeywell Limitée, 35 Dynamic Drive, Scarborough, Ontario M1V 4Z9.

International Sales and Service Offices in all principal cities of the world. Manufacturing in Australia, Canada, Finland, France, Germany, Japan, Mexico, Netherlands, Spain, Taiwan, United Kingdom, U.S.A.

INSTALLATION

When Installing this Product...

1. Read these instructions carefully. Failure to follow them could damage the product or cause a hazardous condition.
2. Check the rating given in the instructions and on the product to make sure the product is suitable for your application.
3. Installer must be a trained, experienced service technician.
4. After installation is complete, check out product operation as provided in these instructions.



CAUTION

Personal Injury Hazard.

Power supply can cause electrical shock.

Disconnect power supply before beginning installation. Do not open base unit or lamp knob; there are no user-serviceable components inside.



WARNING

UV Light Hazard.

Harmful to bare skin and eyes.

Can cause temporary or permanent loss of vision.

Never look at the lamps while illuminated.

Only view illumination by way of the light indicator on the lamp knob.

To prevent exposure to ultraviolet light, disconnect power to the ultraviolet air treatment system before servicing any part of the heating/air conditioning system.

Do not mount device in location that allows ultraviolet light to be seen after installation.

Do not attempt to bypass the duct mount switch.

Selecting Mounting Location



CAUTION

Equipment Damage Hazard.

Ultraviolet light can cause color shift or structural degradation of plastic HVAC materials.

Select mounting location that prevents exposure to plastic components with *unknown resistance to ultraviolet light*. Three-foot minimum is recommended between ultraviolet lamps and plastic-fabricated devices (such as humidifiers and non-fiberglass media filters).

IMPORTANT

If mounting options are limited, protect plastic or rubber material listed in CAUTION with ultraviolet-resistant material such as aluminum foil duct tape.

NOTE: When the installer is uncertain about whether the drip pan in the installation can tolerate UV exposure, consult the UV exposure white paper, form no. 50-8788, at hbctechlit.com Web site.

1. The ultraviolet air treatment system can be mounted in any orientation.
2. Choose a location that is readily accessible for regular inspection and cleaning.
3. Allow clearance in front of the device for removing the lamp assemblies. See Fig. 2 for lamp assembly lengths.
4. Select mounting location that prevents exposure to plastic components with unknown resistance to ultraviolet light. A minimum of three feet is required between the ultraviolet lamps and devices fabricated of plastic, such as humidifiers.
5. Mount the ultraviolet air treatment system to non-lined metal ductwork. Do not mount in a location that permits ultraviolet exposure to plastic flexible duct liner.



CAUTION

Sharp Edges Hazard.

Can cause personal injury.

Be careful when inserting ultraviolet device into the sheet metal cutout.

Wear protective gloves when working near sheet metal.

Duct Mounting

Use the following instructions to mount the air treatment system on the air duct of an HVAC system:

1. Disconnect power to the HVAC system before installing the Ultraviolet Air Treatment System.
2. Determine the location for installation (see Fig. 1):
 - a. The single-lamp and dual-lamp units require an easily-accessible, flat mounting surface on the metal return air duct of the HVAC system. The coil irradiation unit requires an easily-accessible, flat mounting surface on the metal supply air duct of the HVAC system. The coil irradiation unit must be located so the lamp surrounds the evaporator coil and drip pan with ultraviolet light.
 - b. The duct mounting location must be a minimum of 8 in. wide. See Fig. 2.
 - c. The depth of the duct must accommodate the full length of the ultraviolet lamp for your model as shown in Fig. 2.
 - d. The unit should be located as far away as possible from any rubber or plastic components, such as isolators, in the duct.
 - e. The space adjacent to the mounting location must be large enough to allow for ultraviolet lamp installation and removal.
 - f. A 120 Vac electrical outlet must be within range of the unit to plug in the power cord.

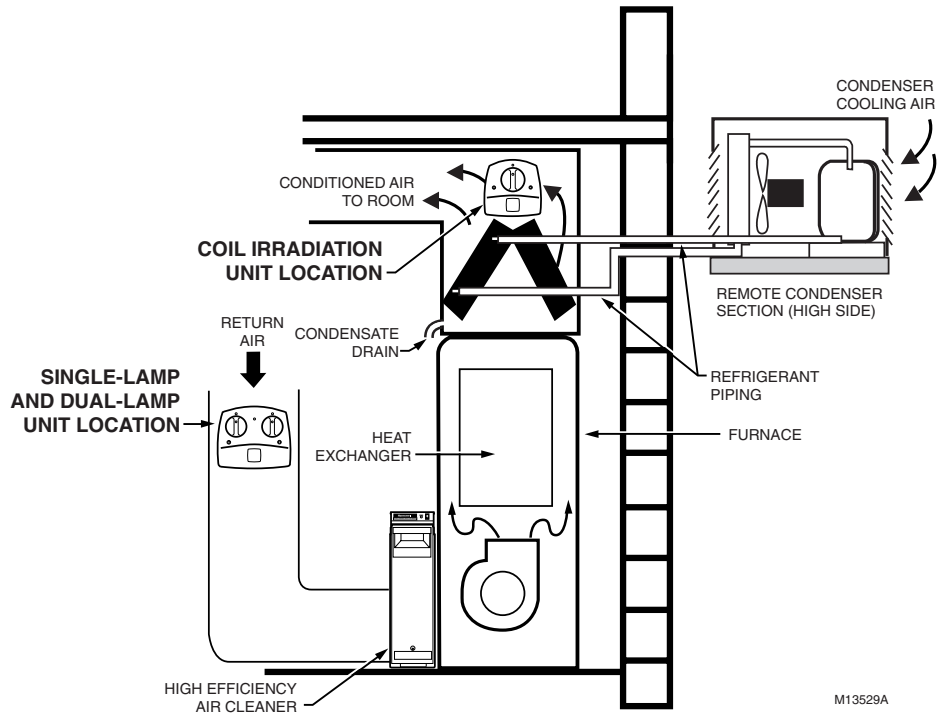

Fig. 1. Possible mounting locations for Ultraviolet Air Treatment Systems.

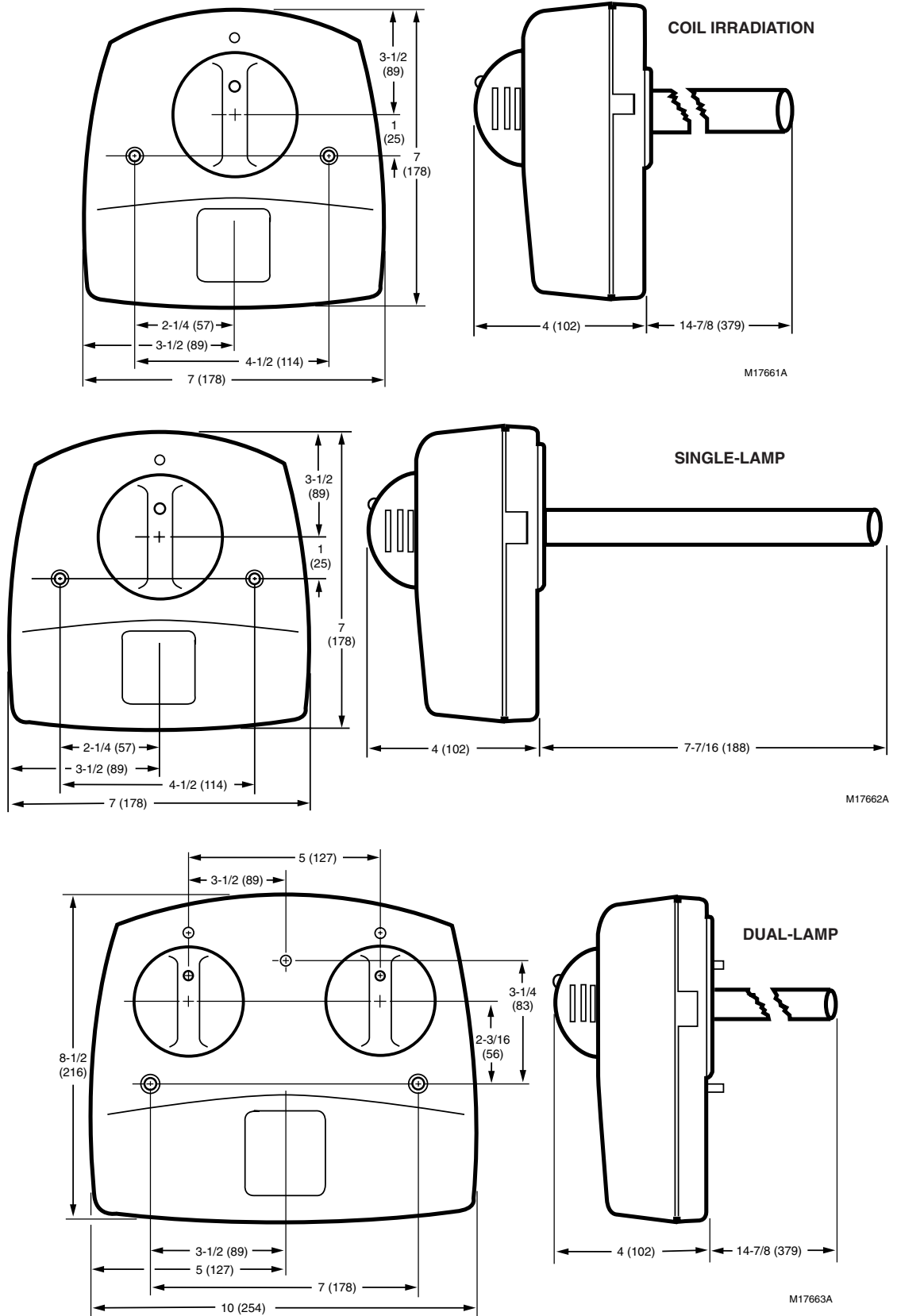

Fig. 2. Ultraviolet Air Treatment System dimensions in in. (mm).

- Place the appropriate template for your model on the duct surface, centering the lamp hole(s) on the duct. See Fig. 3 (below and next page) for the template for your model.

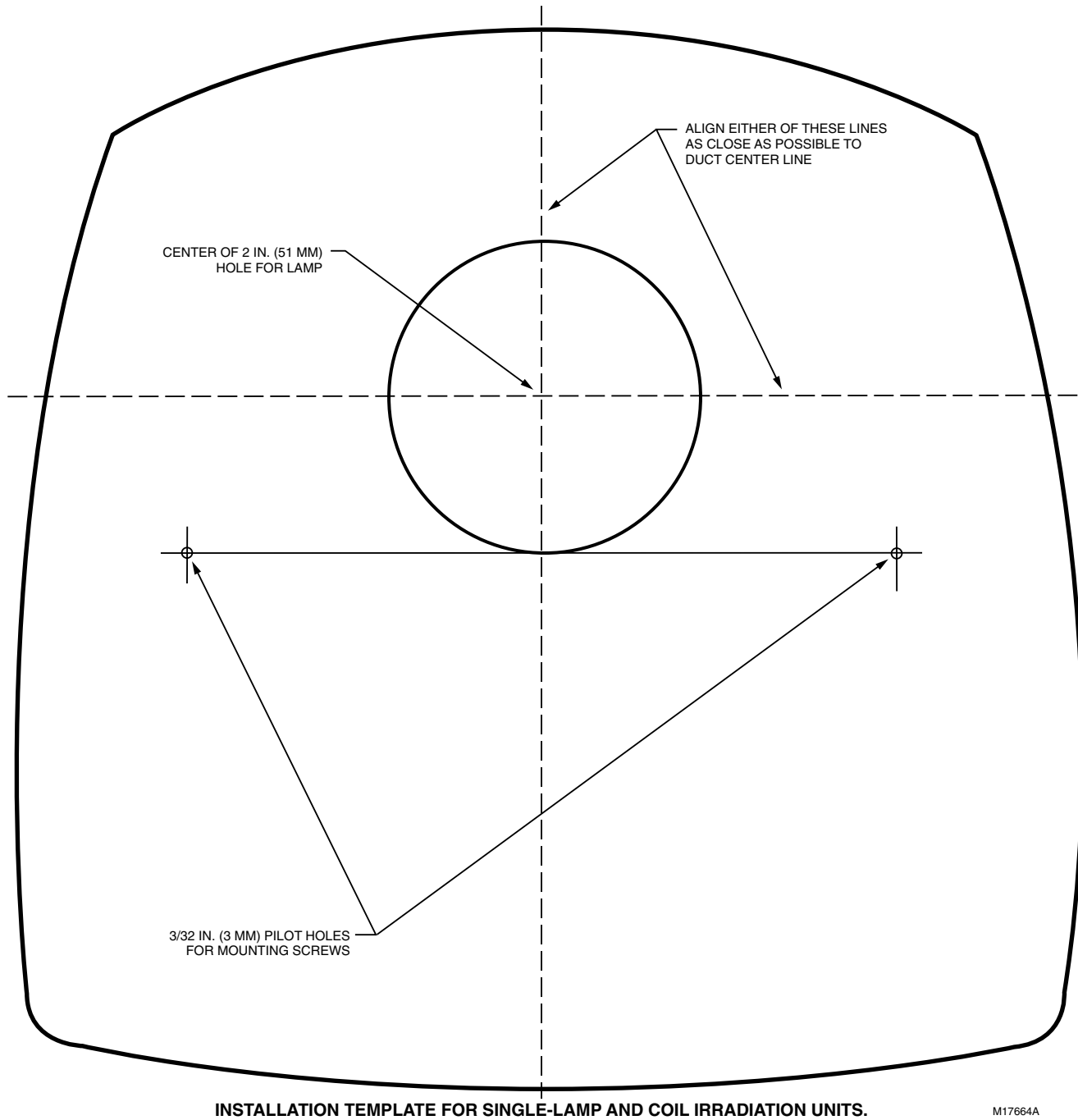
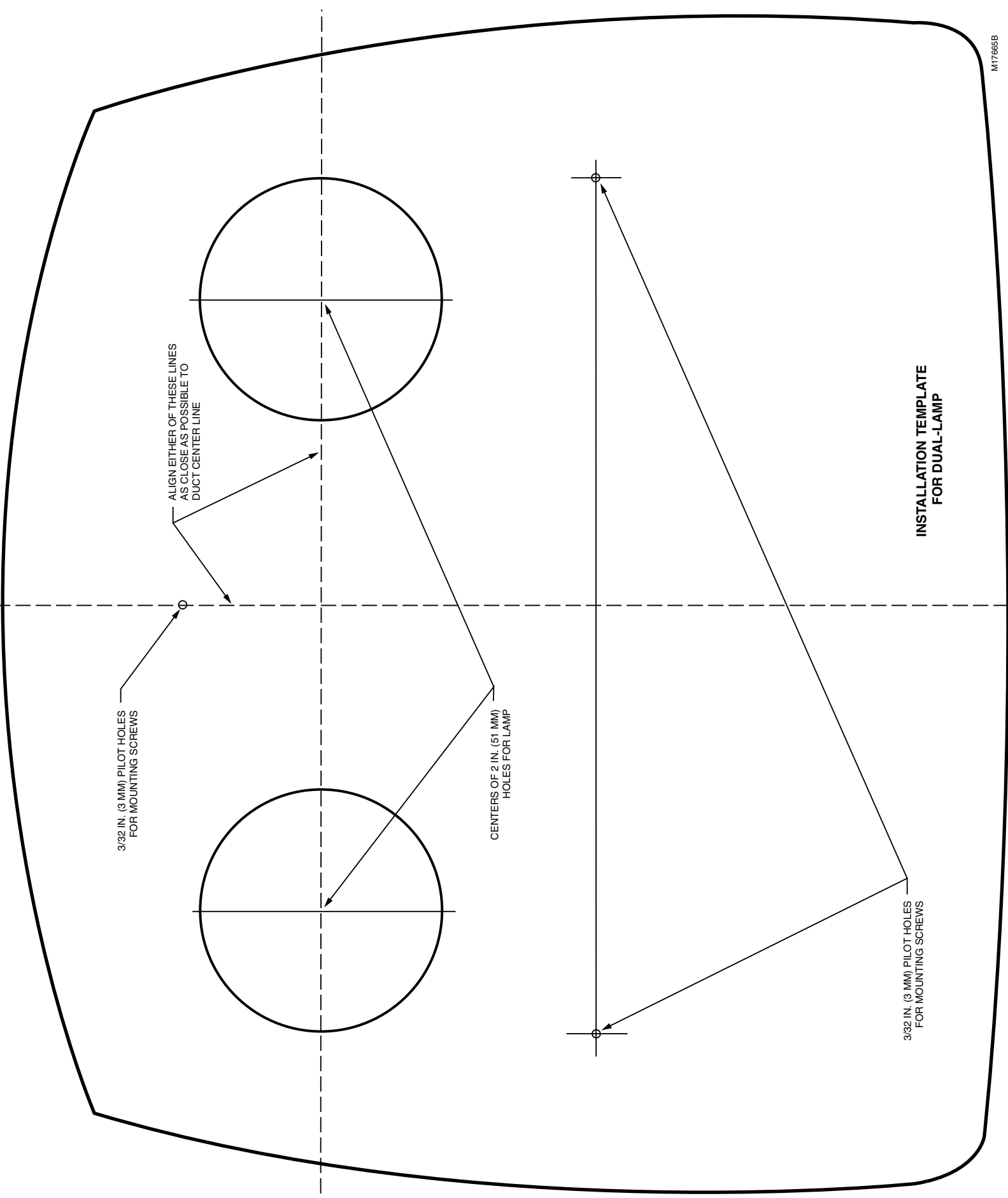

Fig. 3. Ultraviolet Air Treatment System templates.

- Mark the location on the duct for the 2 in. diameter lamp hole(s) and the unit mounting-screw pilot holes.
- Cut the 2 in. lamp hole(s) in the duct. Remove any burrs.
- Use a 3/32- in. drill to provide pilot holes for the mounting screws.
- Be sure the duct surface is flat after all holes are drilled.
- Position the entire base unit on the duct. Be sure the lamp holes in the duct align with those in the unit to allow lamp insertion.
- Install the unit into the duct using the three (or two, depending on the model) no.10, 2 in. Phillips head sheet metal mounting screws provided. (There is a spare screw provided for the three-screw model.)
- Tighten the screws to 12 to 14 in.-lb so the space between the case and duct is sealed.



3/32 IN. (3 MM) PILOT HOLES FOR MOUNTING SCREWS

ALIGN EITHER OF THESE LINES AS CLOSE AS POSSIBLE TO DUCT CENTER LINE

CENTERS OF 2 IN. (51 MM) HOLES FOR LAMP

3/32 IN. (3 MM) PILOT HOLES FOR MOUNTING SCREWS

INSTALLATION TEMPLATE FOR DUAL-LAMP



CAUTION

Breakable Glass Hazard.

Can cause personal injury.

Be careful when inserting lamps(s) into lamp base.
Wear protective gloves when handling lamp(s).



MERCURY NOTICE

This device contains mercury in the sealed ultraviolet lamp(s). Do not place your used lamp(s) in the trash. Dispose of properly.

Broken Lamp Cleanup.

Do not use a household vacuum.

Sweep debris into a plastic bag and dispose of properly.

Contact your local waste management authority for instructions regarding recycling and the proper disposal of old lamp(s).

11. Insert the lamp into the base unit with the lamp light indicator at the eleven o'clock position (left of the raised button on the unit cover). *Do not touch the lamp surface with your hands.*
12. Continue lightly pushing in on the lamp while rotating it slowly counterclockwise. This should cause the lamp to drop into the bottom of the lamp well.
13. Rotate the lamp clockwise until it snaps into place with the lamp indicator light aligned with the raised button on the unit cover.



WARNING

UV Light Hazard.

Harmful to bare skin and eyes.

Can cause temporary or permanent loss of vision.

Never look at the lamps while illuminated.
Only view illumination by way of the light indicator located on the lamp knob.

To prevent exposure to ultraviolet light, disconnect power to the ultraviolet air treatment system before servicing any part of the heating/air conditioning system.

14. Plug the cord into the nearby 120 Vac electrical outlet.
15. Reconnect the power to the HVAC system.
16. Choose a location on the adjacent HVAC equipment for the HVAC maintenance label included in the air treatment system packing box. Choose a location that a future installer can easily see during any future HVAC maintenance or repair.
17. Adhere the HVAC maintenance label to the HVAC equipment (selected in step 16) such as the furnace, air cleaner or humidifier.

CHECKOUT

The installer should verify that the ultraviolet lamp(s) are operating *only by viewing the lamp indicator on the lamp knob. Do not attempt to look directly into the duct to see the illuminated ultraviolet lamps.*

The installer should orient the homeowner to the unit by showing them the blue glow of the lamp indicator and discussing how to determine when the unit is functioning properly without looking directly into the duct to see the illuminated ultraviolet lamps. The installer should also emphasize the hot surface and electrical shock safety warnings.

The installer should leave the Owner's Guide with the homeowner and review the lamp cleaning and lamp replacement procedures. A Lamp Cleaning Schedule is included in the Owner's Guide to help the homeowner set up and track a regular cleaning schedule.

TROUBLESHOOTING AND SERVICE

The Ultraviolet Air Treatment System has no field-serviceable parts. Lamp cleaning is recommended as routine maintenance four times a year or every three months (quarterly). Annual lamp replacement is required. See the Owner's Guide for detailed procedural information.

MAINTENANCE

How You Can Maintain Your Ultraviolet Air Treatment System

Your should regularly clean your ultraviolet lamps to maintain your air treatment system. And once every year, you must remember to replace your ultraviolet lamps.



CAUTION

Personal Injury Hazard.
Power supply can cause electrical shock.
 Disconnect power supply before cleaning or replacing ultraviolet lamp(s).
 Do not open base unit or lamp knob; there are no user-serviceable components inside.



CAUTION

Breakable Glass Hazard.
Can cause personal injury.
 Be careful when inserting lamp(s) into lamp base.
 Wear protective gloves when handling lamp(s).

Cleaning Your Lamps Every Three Months (Quarterly)



MERCURY NOTICE

This device contains mercury in the sealed ultraviolet lamp(s). Do not place your used lamp(s) in the trash. Dispose of properly.

Broken Lamp Cleanup.
Do not use a household vacuum.
 Sweep debris into a plastic bag and dispose of properly.

Contact your local waste management authority for instructions regarding recycling and the proper disposal of old lamp(s).

Lamp cleaning is recommended as routine maintenance four times a year or every three months (quarterly). Use the Ultraviolet Lamp Cleaning Reminder Schedule, Fig. 4, to help you establish and track your regular cleaning schedule.



CAUTION

UV Lamp Burn Hazard.
Harmful to bare skin.
Can cause severe burns.
 Disconnect power 15 minutes before removing the ultraviolet lamp(s)

UV LAMP CLEANING REMINDER SCHEDULE

INSTALLATION DATE: (month) _____, (year) _____

YEAR	J	F	M	A	M	J	J	A	S	O	N	D

M13516

Fig. 4. Ultraviolet lamp cleaning reminder schedule.

- To clean your lamps:
1. Disconnect the power to your HVAC system.
 2. Unplug your ultraviolet air treatment system cord from the electrical outlet and allow the lamps to cool for at least 15 minutes.
 3. Rotate your lamp knob counterclockwise and gently pull the lamp knob to remove the lamp(s).
 4. Holding only the lamp knob, wipe the lamp glass using a soft cloth with window cleaner applied to it. Do not touch the lamp surface with your hands. Use only the cloth.
 5. To ensure that the lamp indicator continues to function, use a moistened cotton swab to gently remove any dust that may have collected between the lamp light indicator on the base and the black lamp base.
 6. Wipe your lamps with a clean, dry cloth.
 7. Put your clean lamps back into the unit base by following Replacing Your Lamps (Annually) section steps 5, 6, and 7.



WARNING

UV Light Hazard.
Harmful to bare skin and eyes.
Can cause temporary or permanent loss of vision.
 Never look at the lamps while illuminated.
 Only view illumination by way of the light indicator located on the lamp knob.
 To prevent exposure to ultraviolet light, disconnect power to the ultraviolet air treatment system before servicing any part of the heating/air conditioning system.

8. Plug the cord into the nearby 120 Vac electrical outlet.
9. Verify that the ultraviolet lamp(s) are operating *only* by viewing through the lamp light indicator on the lamp knob. *Never look directly at your lamps while illuminated.*
10. Reconnect the power to your HVAC system.



CAUTION

UV Lamp Burn Hazard.

Harmful to bare skin.

Can cause severe burns.

Disconnect power 15 minutes before removing the ultraviolet lamp(s).

Replacing Your Lamps (Annually)

Annual replacement of your lamps is required. To replace your lamps:

1. Select and obtain the correct replacement lamp for your unit. See Parts List.
2. Disconnect the power to your HVAC system.
3. Unplug your ultraviolet air treatment system cord from the electrical outlet and allow the lamps to cool for at least 15 minutes.
4. Rotate the lamp knob counterclockwise and gently pull the lamp knob to remove the lamp(s).
5. Insert the lamp into the base unit with the lamp light indicator at the eleven o'clock position (left of the raised button on the unit cover). *Do not touch the lamp surface with your hands.*
6. Continue lightly pushing in on the lamp while rotating it slowly counterclockwise. This should cause the lamp to drop into the bottom of the lamp well.

7. Rotate the lamp clockwise until it snaps into place with the lamp light indicator aligned with the raised button on the unit cover.



WARNING

UV Light Hazard.

Harmful to bare skin and eyes.

Can cause temporary or permanent loss of vision.

Never look at the lamps while illuminated.

Only view illumination by way of the light indicator located on the lamp knob.

To prevent exposure to ultraviolet light, disconnect power to the ultraviolet air treatment system before servicing any part of the heating/air conditioning system.

8. Plug your ultraviolet air treatment system cord into the nearby 120 Vac electrical outlet.
9. Verify that your ultraviolet lamp(s) are operating *only by viewing through* the lamp light indicator on the lamp knob. *Never look directly at your lamp(s) while illuminated.*
10. Reconnect the power to your HVAC system.

UV100E Parts List.

Unit Description	Replacement Lamps	Wattage
UV100E1001 Single-Lamp Return Air Unit	UC100E1006	18W
UV100E1019 Dual-Lamp Return Air Unit	UC100E1014 (twin pack) (two lamps provided)	36W each lamp
UV100E1035 Coil Irradiation Unit	UC100E1030	36W

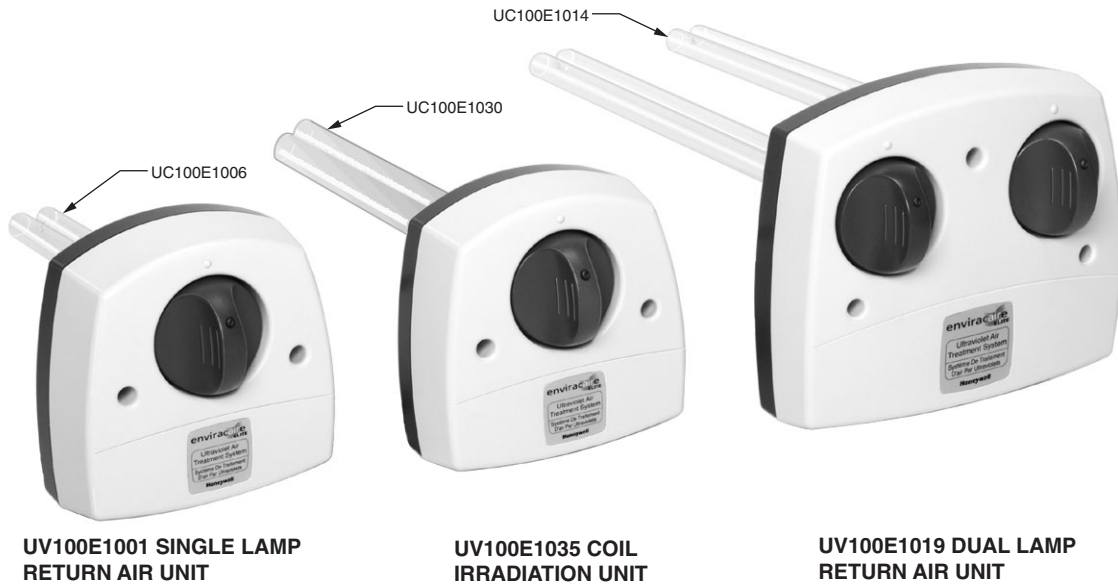

M19013

Honeywell

Choose better indoor air for your family by installing Honeywell solutions. You'll enhance your comfort and peace of mind.



Ultraviolet Air Treatment Systems

Zap airborne germs and prevent mold spore growth on air conditioning coils



Whole-House Air Cleaners

Trap a high percentage of airborne particles of the air passing through it



Whole-House Humidifiers

Moisturize air—40% to 60% humidity is ideal for minimizing adverse health effects



Zoning Systems

Control temperature by area in your home, saving energy and improving comfort



PerfectWindow® Air Exchangers

Ventilate your home to assure fresh air while minimizing energy loss



Programmable Thermostats

Save up to 30% in annual energy costs with this easy-to-use thermostat*

*depending on geography and usage

M18621

Honeywell

Automation and Control Solutions

Honeywell
1985 Douglas Drive North
Golden Valley, MN 55422

Automation and Control Solutions

Honeywell Limited-Honeywell Limitée
35 Dynamic Drive
Scarborough, Ontario
M1V 4Z9

