

# AM-1 Series™

## THERMOSTATIC MIXING VALVES

### SUBMITTAL SHEET

### APPLICATION

The Honeywell AM-1 series accurately adjusts, maintains, and limits the hot water temperature to a desired setting selected by the user. By installing a Honeywell AM-1 mixing valve, raising water heater storage temperature setting, and limiting mixed outlet water temperature to a safe temperature, more usable hot water is available.

### Specifications

**Design:** Straight-Through (hot and cold at the same level)  
**Maximum Pressure:** 150 psi (1034 kPa)  
**Certifications:** ASSE, CSA and IAPMO listed  
**Patent Information:** U.S. Patent No. 6,079,625  
**Warranty:** 1 year limited warranty

### Materials

**Body:** Teflon®-Coated, Nickel-Plated Brass  
**Shuttle:** Teflon®-Coated Brass  
**O-Rings:** EPDM Rubber

\*\*Lead free models available, add LF to the end of the part (Example, AM100-1LF)

### Dimensions

Model Number	Pipe Size	Operating Temp	Cv	ASSE Certs.	Dimensions		
					A	B	C
<b>NPT</b>							
AM100-1	1/2"	70°F - 145°F	3.2	1017	5.8	2.7	3
AM101-1	3/4"	70°F - 145°F	3.8	1017	5.8	2.7	3
AM102-1	1"	70°F - 145°F	4.3	1017	5.8	2.7	3
AM100C-1	1/2"	70°F - 120°F	3.2	1017	5.8	2.7	3
AM101C-1	3/4"	70°F - 120°F	3.8	1017	5.8	2.7	3
AM102C-1	1"	70°F - 120°F	4.3	1017	5.8	2.7	3
<b>Union Threaded</b>							
AM100-UT-1	1/2"	70°F - 145°F	3.9	1017	5.9	2.9	4.9
AM101-UT-1	3/4"	70°F - 145°F	3.9	1017	6.6	3.8	6.5
AM102-UT-1	1"	70°F - 145°F	3.9	1017	6.8	3.9	7
AM100C-UT-1	1/2"	70°F - 120°F	3.9	1017	5.9	2.9	4.9
AM101C-UT-1	3/4"	70°F - 120°F	3.9	1017	6.6	3.8	6.5
AM102C-UT-1	1"	70°F - 120°F	3.9	1017	6.8	3.9	7
AM100R-UT-1	1/2"	70°F - 180°	3.9	N/A	5.9	2.9	4.9
AM101R-UT-1	3/4"	70°F - 180°	3.9	N/A	6.6	3.8	6.5
AM102R-UT-1	1"	70°F - 180°	3.9	N/A	6.8	3.9	7
AM100C1070-UT-1	1/2"	70°F - 120°F	1.8	1017, 1070	5.9	2.9	4.9
AM101C1070-UT-1	3/4"	70°F - 120°F	1.8	1017, 1070	6.6	3.8	6.5
AM102C1070-UT-1	1"	70°F - 120°F	1.8	1017, 1070	6.8	3.9	7
<b>Union PEX</b>							
AM100-UPEX-1	1/2"	70°F - 145°F	3.9	1017	6.0	3.0	5.1
AM101-UPEX-1	3/4"	70°F - 145°F	3.9	1017	6.0	3.0	5.1
AM100C-UPEX-1	1/2"	70°F - 120°F	3.9	1017	6.0	3.0	5.1
AM101C-UPEX-1	3/4"	70°F - 120°F	3.9	1017	6.0	3.0	5.1
AM100R-UPEX-1	1/2"	70°F - 180°	3.9	N/A	6.0	3.0	5.1
AM101R-UPEX-1	3/4"	70°F - 180°	3.9	N/A	6.0	3.0	5.1
AM100C1070-UPEX-1	1/2"	70°F - 120°F	1.8	1017, 1070	6.0	3.0	5.1
AM101C1070-UPEX-1	3/4"	70°F - 120°F	1.8	1017, 1070	6.0	3.0	5.1
<b>Union CPVC</b>							
AM100-UCPVC-1	1/2"	70°F - 145°F	3.9	1017	5.8	2.8	4.7
AM101-UCPVC-1	3/4"	70°F - 145°F	3.9	1017	5.8	2.8	4.7
AM100C-UCPVC-1	1/2"	70°F - 120°F	3.9	1017	5.8	2.8	4.7
AM101C-UCPVC-1	3/4"	70°F - 120°F	3.9	1017	5.8	2.8	4.7
AM100C1070-UCPVC-1	1/2"	70°F - 120°F	1.8	1017, 1070	5.8	2.8	4.7
AM101C1070-UCPVC-1	3/4"	70°F - 120°F	1.8	1017, 1070	5.8	2.8	4.7

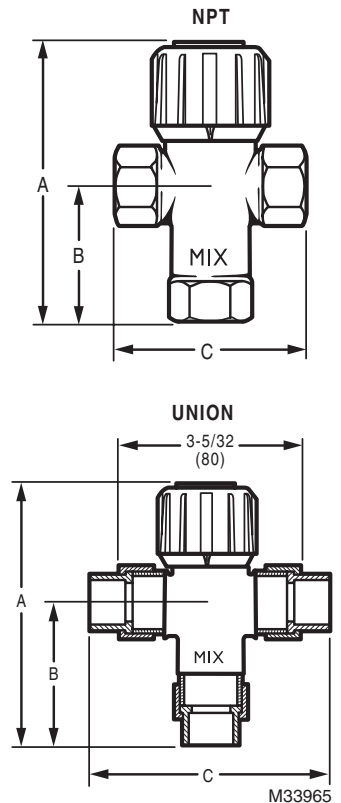

M33965

Job Name \_\_\_\_\_  
 Engineer \_\_\_\_\_  
 Mechanical Contractor \_\_\_\_\_  
 Contractor's P.O. No. \_\_\_\_\_  
 Representative \_\_\_\_\_  
 Notes \_\_\_\_\_

Model(s) \_\_\_\_\_  
 Qty. \_\_\_\_\_  
 Qty. \_\_\_\_\_  
 Qty. \_\_\_\_\_  
 Notes \_\_\_\_\_  
 Notes \_\_\_\_\_  
 Notes \_\_\_\_\_  
 Approval \_\_\_\_\_  
 Service \_\_\_\_\_  
 Tag No. \_\_\_\_\_

**Automation and Control Solutions**  
 Honeywell International Inc.  
 1985 Douglas Drive North  
 Golden Valley, MN 55422  
 customer.honeywell.com

© U.S. Registered Trademark  
 © 2012 Honeywell International Inc.  
 68-3098-01 M.S. 11-12  
 Printed in United States



68-3098-01