



R8182D,E,F,H,J Combination Protectorelay™ Primary Control and Aquastat® Controller

INSTALLATION INSTRUCTIONS

APPLICATION

The R8182 combines a Protectorelay™ primary control and immersion type Aquastat® controller in one unit for use in oil-fired, hydronic heating systems.

The Protectorelay™ primary control provides control of a line voltage, intermittent ignition oil burner when used with a C554A Cadmium Sulfide Flame Detector and a 24V thermostat.

The R8182 models provide switching as follows:

Model	Switching
R8182D	High limit, spst; Low limit/circulator, spdt
R8182E	High limit, spst
R8182F	High limit, spst Circulator, spst
R8182H (with remote bulb)	High limit, spst Low limit/circulator, spdt
R8182J (with remote bulb)	High limit, spst

The auxiliary ZC and ZR terminals on the R8182D,E,H,J provide zone control through an R845A Switching Relay.

All models are capable of zone control using zone valves. Each additional zone requires a separate 24V thermostat and a V8043 or V8044 Zone Valve.

The R8182D,E,F models mount directly on the boiler. The R8182H,J models mount directly on a 4 by 4 inch junction box and have a 5 foot (1.5 meter) armored capillary for remote sensor location.

To order an immersion well, use form 68-0040 Wells and Fittings for Temperature Controllers, for part numbers and descriptions.

Refer to Fig. 1 through 3 for installation dimensions.

Refer to Fig. 4 through 8 for internal views of the R8182D,E,F,G,J.

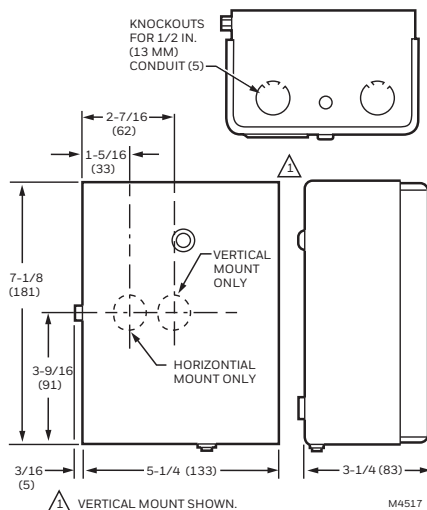

Fig. 1. R8182D,E,F installation dimensions in inches (millimeters).



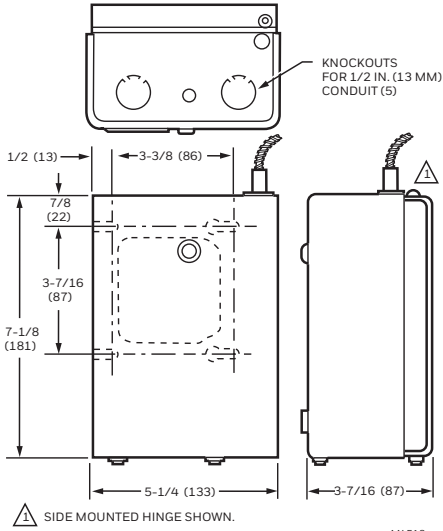
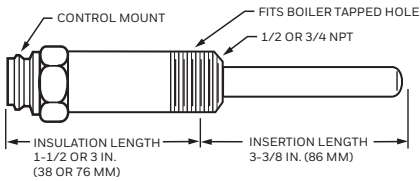

Fig. 2. R8182H,J installation dimensions in inches (millimeters).

R8182D,E,F



R8182H,J

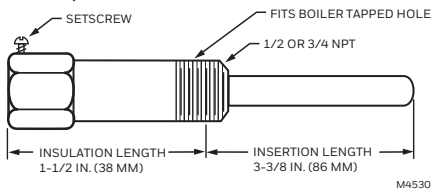

Fig. 3. Immersion well dimensions in inches (millimeters).

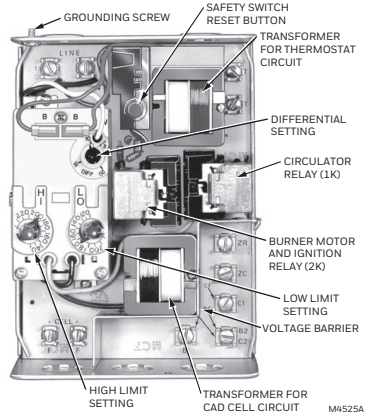

Fig. 4. Internal view of R8182D.

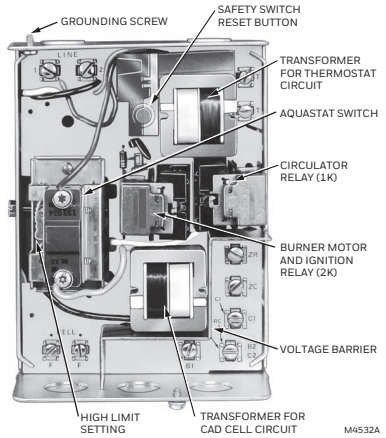

Fig. 5. Internal view of R8182E.

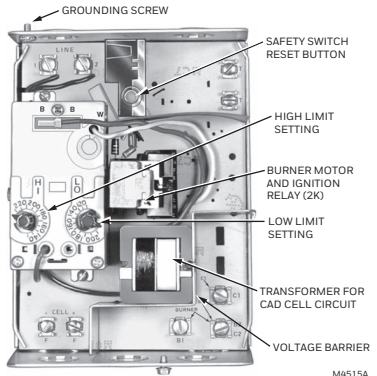

Fig. 6. Internal view of R8182F.

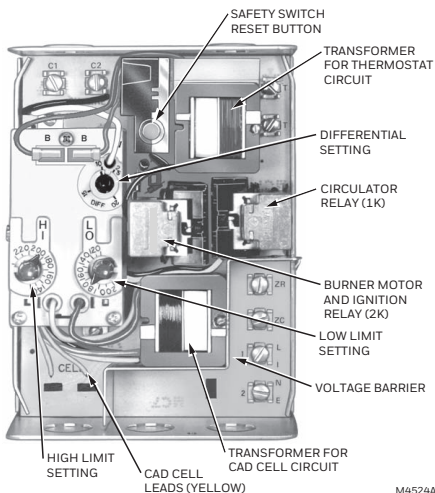

Fig. 7. Internal view of R8182H.

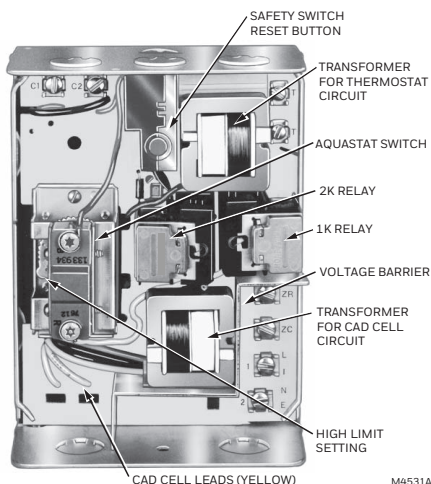

Fig. 8. Internal view of R8182J.

3. Be sure the installer is a trained, experienced service technician.
4. After completing installation, use these instructions to check product operation.

CAUTION

1. Disconnect the power supply before beginning installation to prevent electrical shock or equipment damage.
2. Be sure that the combustion chamber is clear of oil or oil vapor before starting burner.
3. Be sure that the ambient temperature at the element does not exceed 250°F (121°C).

IMPORTANT

Be sure that the sensing bulb fits snugly inside the immersion well and that the sensing bulb rests against the bottom of the immersion well. Refer to Fig. 3.

Mounting the R8182

1. Disconnect power supply.
2. Drain all water from boiler.
3. Most boilers are equipped with a tapping that allows horizontal mounting of immersion well where average temperature boiler water circulates freely. If no tapping is provided, prepare one.
4. Install immersion well or compression fitting (ordered separately) by threading immersion well into tapped hole.
5. For R8182D,E,F models:
 - a. Loosen immersion well clamp screw on side of R8182 case.
 - b. Insert bulb into immersion well until it bottoms.
 - c. If necessary, bend capillary tube to hold bulb against bottom of immersion well.

NOTE: Do not make sharp bends in the tubing. A sharp bend can break the tubing and cause a loss of fill. In models with an adjustable tubing length, pull the extra tubing out of the controller case.

- d. Fit controller case onto immersion well so that immersion well clamp slides over flange of immersion well.
 - e. Securely tighten immersion well clamp screw.
6. For R8182H,J models:
 - a. Loosen the screw holding the hinged backplate to the controller case and swing the backplate away from the controller case.
 - b. Screw the backplate to a 4 by 4 inch junction box.
 - c. Insert bulb into immersion well until it bottoms.
 - d. If necessary, bend capillary tube to hold bulb against bottom of immersion well.

NOTE: Do not make sharp bends in the tubing. A sharp bend can break the tubing and cause a loss of fill. In models with an adjustable tubing length, pull the extra tubing out of the controller case.

- e. Tighten immersion well screw over brass collar.
 - f. After wiring, swing the control against the backplate and refasten the screw.
7. Refill the boiler and check for water leakage.

INSTALLATION

When Installing this Product...

1. Read these instructions carefully. Failure to follow them could damage the product or cause a hazardous condition.
2. Check the ratings given in these instructions and on the product to be sure the product is suitable for your application.

Wiring

IMPORTANT

Use Underwriters Laboratories Inc. listed connectors when making external circuit connections to the orange and white line voltage burner and ignition leadwires of the R8182H,J.

CAUTION

Disconnect power supply before wiring to prevent electrical shock or equipment damage.

All wiring must comply with local codes, regulations, and ordinances.

IMPORTANT

Terminals on the R8182 are approved for copper wire only.

Follow the wiring instructions furnished by the appliance manufacturer, if available, or refer to Fig. 9 through 15. For wiring multiple zoning systems, refer to Fig. 14 and 15.

The R8182 is equipped with special wiring terminals. Wires can be wrapped around the terminal screw or inserted from the side.

Method 1

- Strip 7/16 inches of insulation from the wire end.
- Wrap wire 3/4 of distance around screw as shown in Method 1.
- Use a standard, flat-headed screwdriver to tighten screw until wire is snugly in contact with screw and contact plate.
- Tighten the screw an additional one half turn.

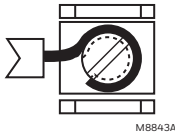

Method 2

- Strip 5/16 inches of insulation from the wire end.
- Insert wire beneath screw as shown in method 2.
- Using a standard, flat-headed screwdriver, tighten screw until wire is snugly in contact with screw and contact plate.

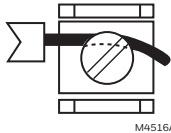

OPERATION

R8182D

A call for heat by the thermostat pulls in relays 1K and 2K to turn on the burner. Safety switch starts to heat. If burner ignites within safety switch timing, cad cell sees flame and safety switch heater circuit is bypassed. Burner operates until call for heat is satisfied. Circulator operates when relay 1K pulls in only if R to W is made in the Aquastat® controller.

When R to B (low-limit) is made by a drop in water temperature, it acts as a call for heat, pulling in relay 2K to turn on the burner. Circulator cannot operate. See Fig. 4, 9, 14, 15, and 17.

- Tighten screw an additional one half turn.

NOTE: Do not use a push-type ratchet screwdriver.

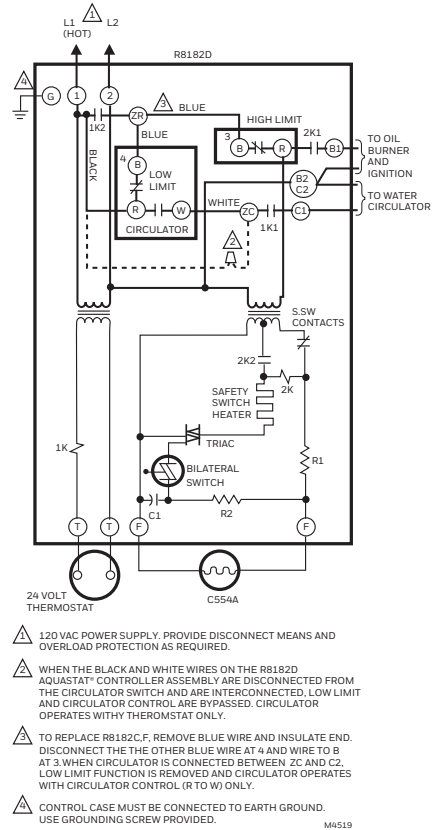

Fig. 9. R8182D internal schematic and wiring diagram.

R8182E

Burner and circulator operate whenever thermostat calls for heat. Relay 2K pulls in. When cadmium sulfide cell sees flame, the safety switch heater circuit is bypassed. 2K is held in through 2K1. If temperature rises to high limit setpoint, R to B breaks, shutting off burner. Circulator continues operation under direction of thermostat. See Fig. 5 10, 15, and 16.

R8182F

A thermostat call for heat pulls in relay 2K to turn on the burner. When cadmium sulfide cell sees flame, safety switch heater circuit is bypassed. Circulator is independent of thermostat circuit, being controlled only by Aquastat® controller switch. Refer to Fig. 6, 11, 15, and 18.

R8182H

A call for heat by the thermostat pulls in relays 1K and 2K to turn on the burner. Safety switch starts to heat. If burner ignites within safety switch timing, cadmium sulfide cell sees flame and safety switch heater circuit is bypassed. Burner shuts off when call for heat is satisfied. Circulator operates when relay 1K pulls in only if R to W in the Aquastat® controller is made.

When R to B (low-limit) is made by a drop in water temperature, it acts as a call for heat, pulling in relay 2K to turn on the burner. Circulator cannot operate. See Fig. 7, 12, 15, and 17.

R8182J

Burner and circulator operate whenever the thermostat calls for heat. Relay 2K pulls in. When cadmium sulfide cell sees flame, the safety switch heater circuit is bypassed. 2K is held in through 2K1. If temperature rises to high-limit setpoint, R to B breaks, shutting off burner. Circulator continues operation under direction of thermostat. See Fig. 8, 13, 15, and 16.

Multizone Control

In all multizone applications, a call for heat in any zone energizes the safety switch circuit and relay 2K pulls in. If burner ignites within safety switch timing, cad cell sees flame and safety switch heater is bypassed.

In all multizone applications with R8182D and H, the low-limit controller in the Aquastat® acts independently to turn on the main burner on a drop in water temperature. When R to B (low-limit) is made, relay 2K pulls in to turn on the main burner, the same as for single-zone applications.

Zone Circulator Control with R8182D,H

The relay for each zone is connected to the Aquastat® controller through terminals ZC and ZR. The R845 Relay and thermostat for each zone can energize the zone circulator through ZC only if R to W in the Aquastat® controller is made. If R to B (high-limit) is made, the zone thermostat energizes the burner through ZR.

Zone Circulator Control with R8182E,J

The relay for each zone is connected to the Aquastat® controller through terminals ZC and ZR. The R845A Relay and thermostat in each zone can energize the zone circulator through ZC on a call for heat. If R to B (high-limit) is made, the zone thermostat energizes the burner through ZR.

Zone Valve Control with R8182

The valve for each zone is connected to the Aquastat® controller by wiring end switches on the zone valve to T-T on the R8182. On a call for heat from any zone, the R8182 operates the same as in single-zone applications.

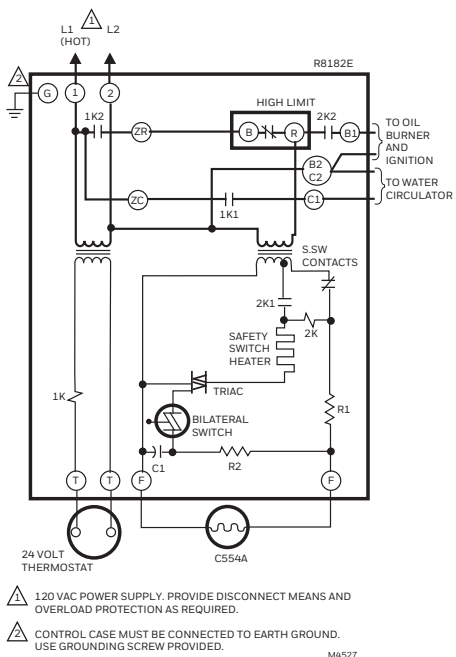

Fig. 10. R8182E internal schematic and wiring diagram.

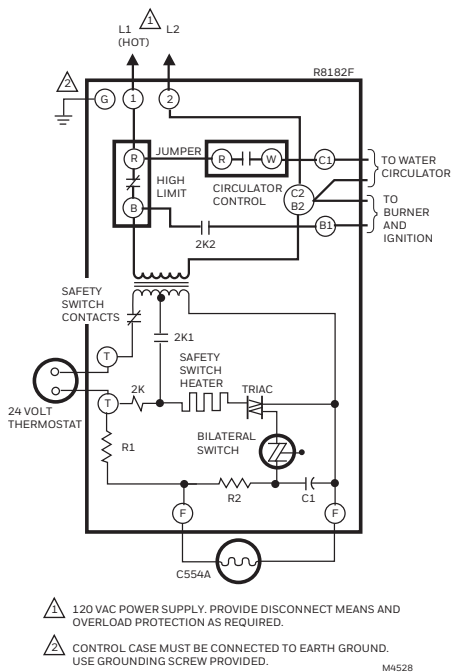

Fig. 11. R8182F internal schematic and wiring diagram.

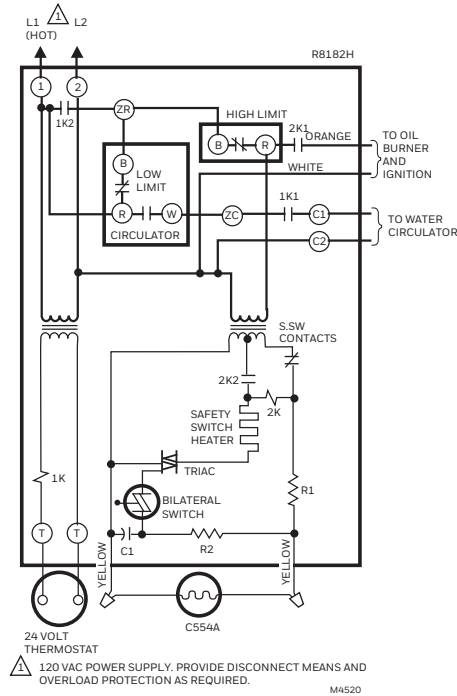

Fig. 12. R8182H internal schematic and wiring diagram.

STARTUP AND CHECKOUT

⚠ WARNING CAN CAUSE PROPERTY DAMAGE, SEVERE INJURY OR DEATH.

This product is intended for use only in systems with a pressure relief valve.

Because heating systems differ, the correct temperature setting for one system may not be correct for another. Follow the boiler manufacturer recommendations for proper selection of settings.

High-Limit Setting—All Models

The high-limit opens and turns off the burner when the water temperature reaches the setpoint. The high-limit automatically resets after the water temperature drops past the setpoint and through the 10°F (6°C) (15°F [8°C] with R8182E,J) differential.

Set the indicator at desired shutoff temperature.

Low-Limit/Circulator Setting—D and H Models (Fig. 17)

On a temperature rise, with the adjustable differential at the minimum setting of 10°F (6°C), the burner circuit (RB) breaks and the circulator circuit (R-W) makes at the low-

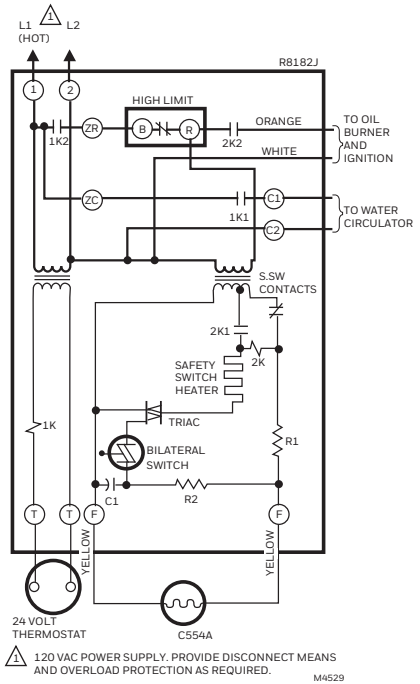

Fig. 13. R8182J internal schematic and wiring diagram.

limit setpoint. See Fig. 17. On a temperature drop of 10°F (6°C) below the setpoint, the R-B circuit makes and the R-W circuit breaks.

At any differential setting greater than 10°F (6°C), the RB make temperature and R-W break temperature remain the same—control setting minus 10°F (6°C). The R-B break and R-W make temperatures are the setpoint temperature plus the difference between the differential setting and 10°F (6°C).

EXAMPLE: Setpoint of 140°F (60°C), differential set at 25°F (14°C). On a temperature rise, R-B breaks and RW makes at 155°F (68°C). On a temperature fall, R-B makes and R-W breaks at 130°F (54°C).

Set low-limit indicator at the minimum water temperature recommended for domestic hot water supply. The setting must be at least 20°F (11°C) below high-limit setting to prevent one switch from locking out the other. Set differential the desired number of degrees.

Circulator Setting—F MODELS (Fig. 18)

Set circulator indicator at the minimum water temperature recommended for hydronic heating comfort. Circulator breaks 10°F (6°C) below setpoint.

Startup

CAUTION

Be sure combustion chamber is free of oil or vapor.

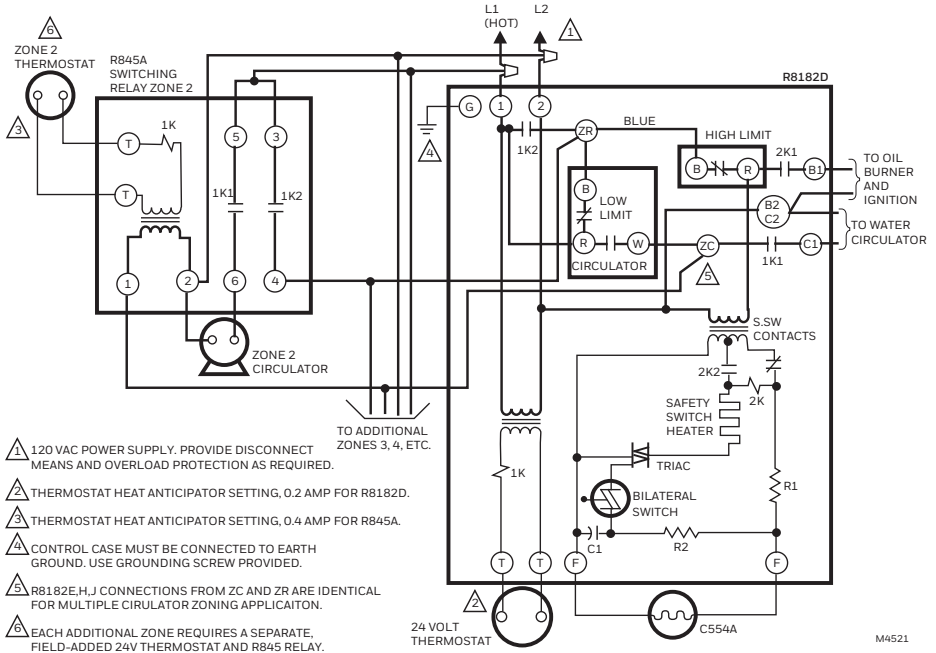

Fig. 14. R8182D and R845A in a typical multiple circulator zoning application.

1. Push red reset button and release.
2. Open hand valve on oil supply line.
3. Set thermostat to call for heat.
4. Close line switch; burner will start.
5. Under normal conditions, burner operates until thermostat is satisfied or line switch is opened.

Make certain the system operates as described in the OPERATION section. Use the following procedure to verify that the Protectorelay™ control is controlling properly.

Flame Failure Check

Shut off oil supply hand valve while burner is on. After 45 seconds, the safety switch locks out, the motor stops, and the oil valve closes. Allow five minutes for burner to cool, then manually reset safety switch.

Ignition Failure Check

Test by closing oil supply while burner is off. Run through starting procedure but do not open the oil supply line hand valve. Safety switch locks out as for flame failure. Then turn oil back on, and reset safety switch.

Power Failure Check

Turn off power supply while burner is on. When burner goes out, restore power and burner will reset.

NOTE: If operation is not as described, see cover insert for additional information and check wiring.

Aquastat® Replacement

The Aquastat® controller section of the Protectorelay™ control is field replaceable. When ordering a replacement assembly, specify the complete model number of the R8182.

To Replace the Aquastat® Limit:

1. Disconnect power supply.
2. Note the position of the connecting wires.
3. Remove fastening screws and wires.
4. Remove Aquastat controller and install new assembly.

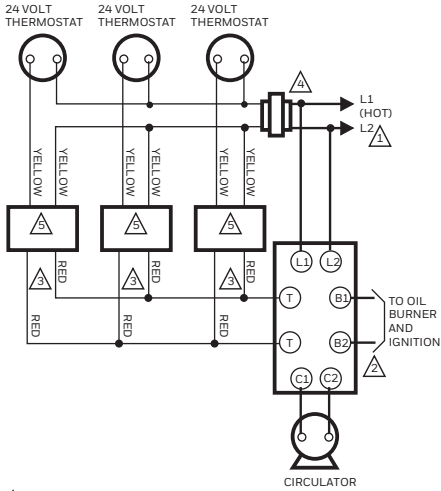

- POWER SUPPLY. PROVIDE DISCONNECT MEANS AND OVERLOAD PROTECTION AS REQUIRED.
- R8182H and J HAVE WHITE AND ORANGE LEADWIRES FOR OIL BURNER AND IGNITION CONNECTIONS.
- RED LEADWIRES PROVIDED ONLY ON MODLES WITH END SWITCH.
- CHOOSE AT72, AT87, OR AT88 TRANSFORMER TO MATCH MAXIMUM SYSTEM LOAD.
- USE V8043 OR V8044 ZONE VALVES WITH AUXILIARY END SWITCH ONLY.

Fig. 15. R8182D,E,F,H, and J in typical zoning application using zone valves.

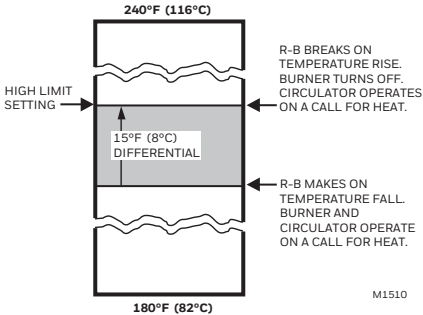

Fig. 16. R8182E,J Aquastat® limit switching.

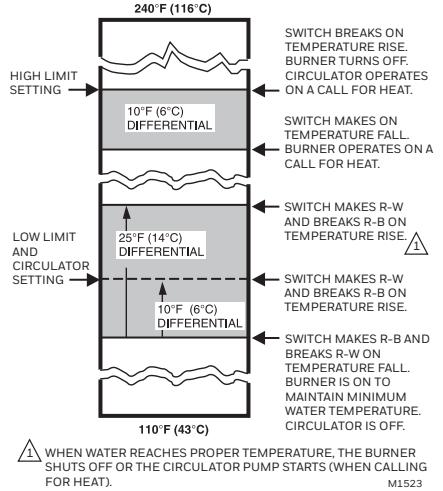

Fig. 17. R8182D,H Aquastat® limit switching.

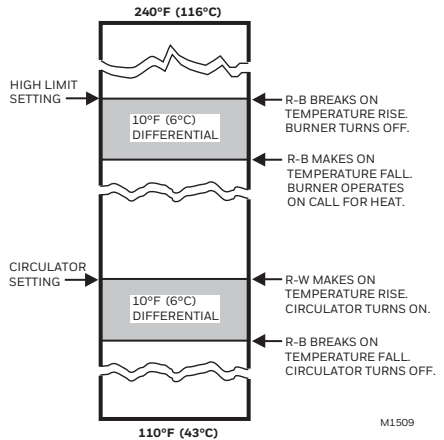

Fig. 18. R8182F Aquastat® limit switching.



Resideo Technologies, Inc.
 1985 Douglas Drive North, Golden Valley, MN 55422
 1-800-468-1502

www.resideo.com 69-0600-02 M.S. Rev. 06-21 | Printed in United States