



VR4304

Intermittent Pilot Combination Gas Control

INSTALLATION INSTRUCTIONS

APPLICATION

These intermittent pilot gas controls are used in gas-fired appliances with capacities up to 300 feet³/hour at 1 inch wc pressure drop [8.5 meters³/hour at 0.25 kPa] for natural gas. They include a manual valve, two automatic operators, a pressure regulator, pilot adjustment and a conduit cover.

The ambient temperature range for the standard-opening model (VR4304M) is -40° to +175°F [-40° to +79°C].

Capacity:

Size (Inlet x Outlet)	Capacity (at 1 inch wc pressure drop) ^a	Minimum Regulated Capacity	Maximum Regulated Capacity
1/2 x 1/2	240 feet ³ /hour [6.8 meter ³ /hour]	30 feet ³ /hour [0.8 meter ³ /hour]	340 feet ³ /hour [9.6 meter ³ /hour]
1/2 x 3/4	270 feet ³ /hour [7.6 meter ³ /hour]	30 feet ³ /hour [0.8 meter ³ /hour]	370 feet ³ /hour [10.5 meter ³ /hour]
3/4 x 3/4	300 feet ³ /hour [8.5 meter ³ /hour]	30 feet ³ /hour 0.8 meter ³ /hour]	415 feet ³ /hour [11.8 meter ³ /hour]

^a Capacity based on 1000 Btu/feet³, 0.64 specific gravity natural gas at 1 inch wc pressure drop [37.3 MJ/meter³, 0.64 specific gravity natural gas at 0.25 kPa pressure drop].

Use conversion factors in Table 1 to convert capacities for other gases.

Table 1. Gas Capacity Conversion Factors.

Gas	Specific Gravity	Multiply Listed Capacity By
Manufactured	0.60	0.516
Mixed	0.70	0.765
Propane	1.53	1.62

Body Pattern: Straight-through.

Inlet x Outlet Sizes Available: 1/2 x 3/4 inch and 3/4 x 3/4 inch.

This gas control comes with two 3/4 to 1/2 inch NPT bushings and one 1/2 to 3/8 inch NPT bushing.

Adapters: Adapters available for 1/2 and 3/4 inch straight and angle connections. Refer to Table 2.

Electrical Ratings:

Voltage and Frequency: 120 Vac, 60 Hz.

Current Draw: 0.14A.

Table 2. Adapter (Flange) Part Numbers.

Inlet/Outlet Pipe Size	Flange Type	Part Number	
		Without Hex Wrench	With Hex Wrench
1/2 inch NPT	Straight	393690-6	393690-16
	Elbow	393690-3	393690-13
3/4 inch NPT	Straight	393690-4	393690-14
	Elbow	393690-5	393690-15

Approvals:

American Gas Association design certificate:
L2025007.

Canadian Gas Association design certificate:
L2025007.

Australian Gas Association design certificate:
Applied for.
Delta C.



INSTALLATION

WHEN INSTALLING THIS PRODUCT...

1. Read these instructions carefully. Failure to follow them could damage the product or cause a hazardous condition.
2. Check the ratings given in the instructions and on the product to make sure the product is suitable for your application.
3. The installer must be a trained, experienced service technician.
4. After installation is complete, use these instructions to check out product operation.

WARNING

FIRE OR EXPLOSION HAZARD CAN CAUSE PROPERTY DAMAGE, SEVERE INJURY, OR DEATH
Follow these warnings exactly:

1. Disconnect power supply before wiring to prevent electrical shock or equipment damage.
2. To avoid dangerous accumulation of fuel gas, turn off gas supply at the appliance service valve before starting installation, and perform Gas Leak Test after completion of installation.
3. Do not bend pilot tubing at gas control or pilot burner after compression fitting has been tightened because gas leakage at the connection can result.
4. Always install sediment trap in gas supply line to prevent contamination of gas control.
5. Do not force the gas control knob. Use only your hand to turn the gas control knob. Never use any tools. If the gas control knob will not operate by hand, call a qualified service technician to replace the gas control. Force or attempted repair can result in fire or explosion.

CAUTION

1. Never apply a jumper across or short the valve coil terminals. This can burn out the heat anticipator in the thermostat or damage the electronic intermittent pilot (IP) module.
2. When a gas control is installed external to the appliance, a conduit cover *must* be installed. See Fig. 1. Place the conduit cover over the flange, then rotate the conduit cover into position.

IMPORTANT

These gas controls are shipped with protective seals over inlet and outlet tappings. Do not remove seals until ready to connect piping.

Follow the appliance manufacturer instructions if available; otherwise, use the following instructions.

CONVERTING BETWEEN NATURAL AND LP GAS

 **WARNING**
FIRE OR EXPLOSION HAZARD CAN CAUSE PROPERTY DAMAGE, SEVERE INJURY, OR DEATH
Do not attempt to use a gas control set for natural gas on LP gas or a gas control set for LP gas on natural gas.

Convert standard-opening gas controls from natural gas to LP gas with the conversion kit included with this gas control. Part number 393691 will convert from natural to LP gas. Part number 394588 will convert from LP to natural gas.

INSTALL ADAPTERS TO GAS CONTROL

Install adapters to gas control as follows:

Flanges

1. Choose the appropriate flange for your application.
2. Remove seal over gas control inlet or outlet.
3. Make sure the O-ring fits into the flange groove. If the O-ring is not attached or is missing, do not use the flange.
4. With the O-ring facing the gas control, align the screw holes on the gas control with the holes in the flange. Insert and tighten the screws provided with the flange. See Fig. 1. Tighten the screws to 25 inch-pounds of torque to provide a gas-tight seal.

Bushings

1. Remove seal over gas control inlet or outlet.
2. Apply moderate amount of good quality pipe compound to bushing, leaving two end threads bare. See Fig. 3. On an LP installation, use compound resistant to LP gas. *Do not use Teflon tape.*
3. Insert bushing in gas control and carefully thread pipe into the bushing until tight.

USING ADAPTERS TO SOLVE SWING RADIUS PROBLEMS

In some field service applications, space limitations make it difficult or impossible to thread the gas control onto the gas supply pipe. This problem can be resolved for many installations by using an adapter. Install the adapter on the end of the supply pipe in place of the gas control by following the same precautions and instructions that are used for installing the gas control. After the adapter is installed, attach the gas control to the adapter as outlined above.

NOTE: Using an adapter increases the overall length of the gas control.

LOCATION

Locate the combination gas control in the appliance vestibule on the gas manifold. In replacement applications, locate the gas control in the same location as the old control.

Do not locate the gas control where it can be affected by steam cleaning, high humidity, dripping water, corrosive chemicals, dust or grease accumulation, or excessive heat.

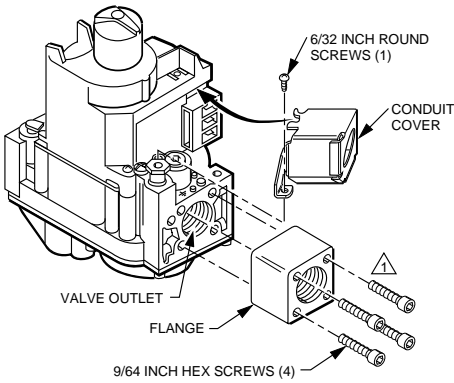

⚠ DO NOT OVERTIGHTEN SCREWS. TIGHTEN TO 25 INCH POUNDS.

M3098A

Fig. 1. Install flange to gas control

To safeguard proper operation, follow these guidelines:

- Locate gas control in a well-ventilated area.
- Mount gas control high enough above the cabinet bottom to avoid exposure to flooding or splashing water.
- Make sure the ambient temperature does not exceed the ambient temperature ratings for each component.
- Cover gas control when the appliance is cleaned with water, steam, or chemicals or to avoid dust and grease accumulation.
- Avoid locating gas control where exposure to corrosive chemical fumes or dripping water is possible.

Install Piping to Gas Control

All piping must comply with applicable codes and ordinances or with the National Fuel Gas Code (ANSI Z223.1 NFPA No. 54), whichever applies. Tubing installation must comply with approved standards and practices.

1. Use new, properly reamed pipe free from chips. If tubing is used, make sure the ends are square, deburred and clean. Make sure all tubing bends are smooth and without deformation.
2. Run pipe or tubing to the gas control. If tubing is used, obtain a tube-to-pipe coupling to connect the tubing to the gas control.
3. Install sediment trap in the supply line to the gas control. See Fig. 2.

Install Gas Control

1. This gas control can be mounted from 0 to 90 degrees in any direction from the vertical position of the gas control knob.
2. Mount the gas control so gas flow is in the direction of the arrow on the bottom of the gas control.

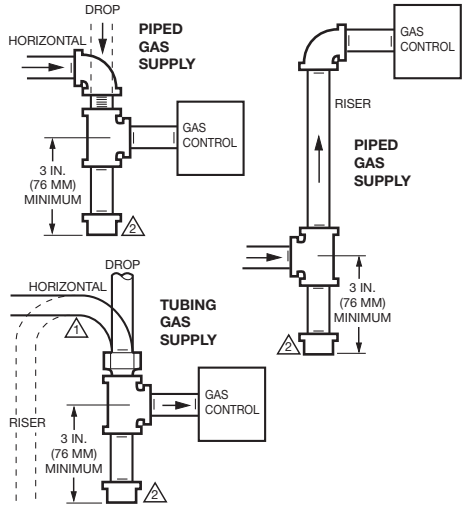

⚠ ALL BENDS IN METALLIC TUBING SHOULD BE SMOOTH.

⚠ CAUTION: SHUT OFF THE MAIN GAS SUPPLY BEFORE REMOVING END CAP TO PREVENT GAS FROM FILLING THE WORK AREA. TEST FOR GAS LEAKAGE WHEN INSTALLATION IS COMPLETE.

M3077C

Fig. 2. Install sediment trap

3. Thread pipe the amount shown in Table 3 for insertion into the gas control or flange. *Do not thread pipe too far.* Valve distortion or malfunction can result when the pipe is inserted too deeply into the gas control.
4. Apply a moderate amount of good quality pipe compound (do not use Teflon tape) to pipe only, leaving two end threads bare. On LP installations, use compound resistant to LP gas. Refer to Fig. 3.

Table 3. NPT pipe thread length in (in.).

Pipe Size	Thread Pipe this Amount	Maximum Depth Pipe can be Inserted into Control
3/8	9/16	3/8
1/2	3/4	1/2
3/4	13/16	3/4

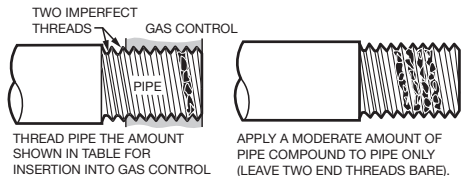

Fig. 3. Use moderate amount of pipe compound

5. Remove seals over gas control inlet and outlet if necessary.
6. Connect pipe to gas control inlet and outlet. Use wrench on the square ends of the gas control. If a flange is used, place wrench on flange rather than on gas control. Refer to Figs. 4 and 5.

Connect Pilot Gas Tubing

1. Cut tubing to desired length and bend as necessary for routing to pilot burner. Do not make sharp bends or deform the tubing. Do not bend tubing at gas control or pilot burner after compression fitting has been tightened because this can result in gas leakage at the connection.
2. Square off and remove burrs from end of tubing.
3. Use the compression fitting supplied with this gas control. Slip the fitting over the tubing and slide out of the way.

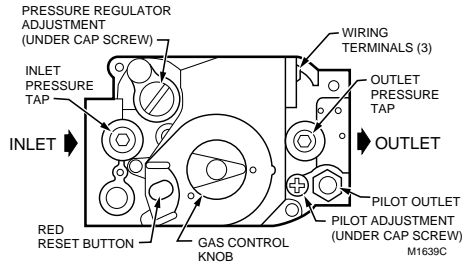

Fig. 4. Top view of gas control

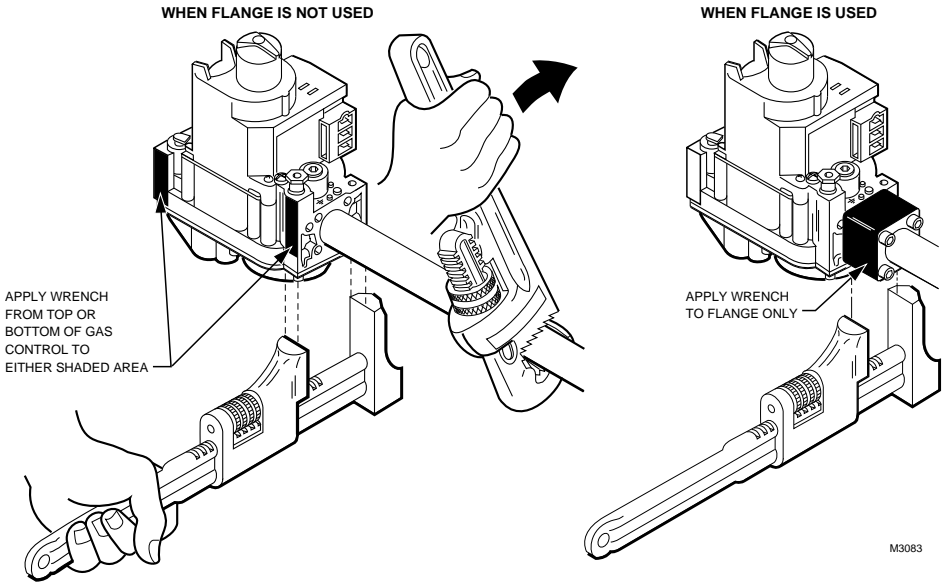

Fig. 5. Proper use of wrench on gas control with and without flanges

NOTE: When replacing a gas control, cut off old compression fitting and replace with the new compression fitting provided on the gas control. Never use the old compression fitting because it may not provide a gas-tight seal.

4. Push tubing into the pilot gas tapping on the outlet end of the control until it bottoms. While holding tubing all the way in, slide compression fitting into place, engage threads and turn until finger tight. Then tighten one more turn with wrench. Do not overtighten. Refer to Fig. 6.
5. Connect other end of tubing to pilot burner according to pilot burner manufacturer instructions.

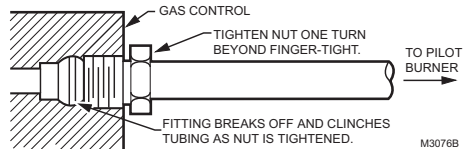

Fig. 6. Always use new compression fitting

All wiring including insulated quick connect terminals must comply with applicable electrical codes and ordinances. Disconnect power supply before making wiring connections to prevent electrical shock or equipment damage.

WIRING

Follow the wiring instructions furnished by the appliance manufacturer, if available, or use the following general instructions provided below. Where these instructions differ from the appliance manufacturer, follow the appliance manufacturer instructions.

1. Check the power supply rating on the gas control and make sure it matches the available supply. Install thermostat and other controls as required.
2. When the gas control is installed external to the appliance, install the conduit cover on the conduit fitting. Do not secure the conduit cover at this time.
3. Connect control circuit to gas control terminals. See Figs. 4 and 7.

NOTE: Use leadwires with insulated terminals.

4. Make sure the conduit cover is in position and secured to the gas valve with the screw provided. See Fig. 1.
5. Adjust thermostat heat anticipator as instructed in appliance manual (i.e., usually 0.1A).

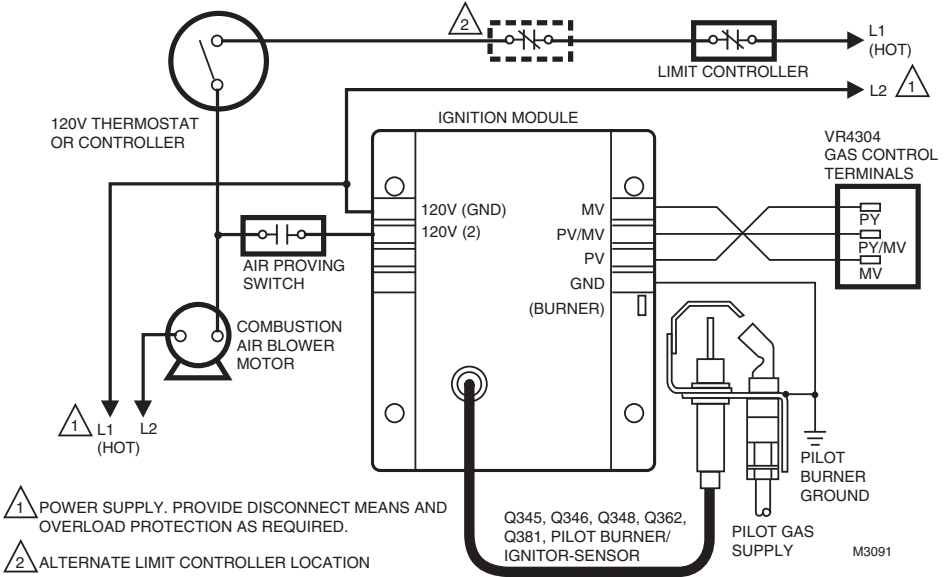

Fig. 7. VR4304 wiring connections in intermittent ignition system

STARTUP AND CHECKOUT

⚠ WARNING

FIRE OR EXPLOSION HAZARD CAN CAUSE PROPERTY DAMAGE, SEVERE INJURY, OR DEATH

1. Do not force the gas control knob. Use only your hand to turn the gas control knob. Never use any tools.
2. If the gas control knob will not operate by hand, call a qualified service technician to replace the gas control.

GAS CONTROL KNOB SETTINGS

The gas control knob settings are as follows:
OFF: Prevents pilot and main burner gas flow.
ON: Permits gas to flow into the control body. Under control of the thermostat and intermittent pilot module, gas can flow to the pilot and main burner.

NOTE: Gas controls are shipped with the gas control knob in the ON position.

TURN ON SYSTEM

Rotate the gas control knob counterclockwise to ON.

TURN ON MAIN BURNER

Follow instructions provided by appliance manufacturer or turn up thermostat to call for heat.

PERFORM GAS LEAK TEST

⚠ WARNING

FIRE OR EXPLOSION HAZARD CAN CAUSE PROPERTY DAMAGE, SEVERE INJURY, OR DEATH

Check for gas leaks with a rich soap and water solution anytime work is done on a gas control.

GAS LEAK TEST

1. Paint all pipe connections upstream of the gas control with a rich soap and water solution. Bubbles indicate a gas leak.
2. If a gas leak is detected, tighten the pipe connection.
3. Stand clear while lighting main burner to prevent injury caused from hidden gas leaks that could cause flashback in the appliance vestibule. Light the main burner.
4. With the main burner in operation, paint all pipe joints (including flanges) and gas control inlet and outlet with a rich soap and water solution.
5. If another gas leak is detected, tighten flange screws, joints, and pipe connections.
6. Replace the part if gas leak can not be stopped.

ADJUST THE PILOT BURNER FLAME

The pilot flame should envelop 3/8 to 1/2 in. [10 to 13 mm] of the igniter-sensor tip. Refer to Fig. 8. To adjust the pilot flame:

1. Remove the pilot adjustment cover screw. Refer to Fig. 4.
2. Turn the inner adjustment screw clockwise to decrease or counterclockwise to increase the pilot flame.
3. To prevent gas leakage always replace the cover screw after adjustment.

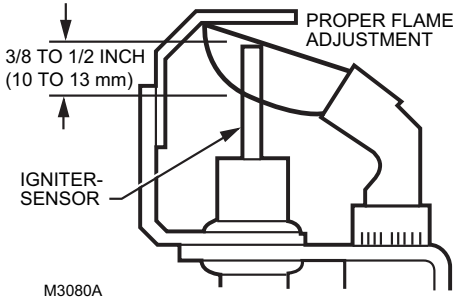

Fig. 8. Proper flame adjustment

CHECK AND ADJUST GAS INPUT TO MAIN BURNER

CAUTION

1. Do not exceed the input rating stamped on the appliance nameplate, or manufacturer recommended burner orifice pressure for the size orifice(s) used. Make certain the primary air supply to the main burner is properly adjusted for complete combustion (refer to the appliance manufacturer instructions).
2. **WHEN CHECKING GAS INPUT BY CLOCKING THE GAS METER:**
 - Make sure that the only gas flow through the meter is that of the appliance being checked.
 - Make certain that other appliances are turned off with pilot burners extinguished (or deduct that gas consumption from the meter reading).
 - Convert the flow rate to Btuh as described in Gas Controls Handbook, form 70-2602, and compare to the Btuh input rating on the appliance nameplate.
3. **WHEN CHECKING GAS INPUT WITH A MANOMETER (PRESSURE GAUGE):**
 - To connect the manometer, be sure the gas control knob is in the OFF position before removing the outlet pressure tap plug.
 - When removing the manometer, turn the gas control knob back to OFF and replace the outlet pressure tap plug.
 - Shut off the gas supply at the appliance service valve, or at the gas tank for LP gas, before removing the outlet pressure tap plug and before disconnecting the manometer and replacing the outlet pressure tap plug.
 - Perform the Gas Leak Test at the outlet pressure tap plug.

Standard-Opening Pressure Regulator

1. The gas control outlet pressure should match the manifold pressure listed on the appliance name-plate.
2. With the main burner operating, check the gas control flow rate by using the meter clamping method or check the gas pressure using a manometer connected to the gas control outlet pressure tap. Refer to Fig. 4.
3. If necessary, adjust the pressure regulator to match the appliance rating. Refer to Table 4 or 5 for the factory set nominal outlet pressures and adjustment setting ranges.
 - a. Remove the pressure regulator adjustment cap screw.
 - b. Using a screwdriver, turn the inner adjustment screw clockwise to increase or counterclockwise to decrease the main burner gas pressure.
 - c. Always replace the cap screw and tighten firmly to safeguard proper operation.
4. If the desired outlet gas pressure or gas flow rate can not be achieved by adjusting the gas control, check the gas control inlet pressure by using a manometer at the inlet pressure tap. If the inlet pressure is in the normal range (refer to Table 4 or 5), replace the gas control. Otherwise, take the necessary steps to provide proper gas pressure to the gas control.

CHECK SAFETY SHUTDOWN PERFORMANCE

WARNING

FIRE OR EXPLOSION HAZARD CAN CAUSE PROPERTY DAMAGE, SEVERE INJURY, OR DEATH
Perform the safety shutdown test anytime work is done on a gas system.

NOTE: Read steps 1 through 7 below before starting and compare to the safety shutdown or safety lockout tests recommended for the intermittent pilot (IP) module. Where they differ, use the procedure recommended for the module.

1. Turn off gas supply.
2. Set the thermostat or controller above room temperature to call for heat.
3. Watch for an ignition spark at pilot burner either immediately or following prepurge. See IP module specifications.
4. If module has timed ignition, time the length of the igniter operation. See IP module specifications.
5. After the module locks out, open gas control knob and make sure there is no gas flow to the pilot or main burner. *With modules that continue spark until pilot lights or system is shut down manually, pilot should light when gas control knob is opened.*
6. Set the thermostat below room temperature and wait one minute.
7. Operate system through one complete cycle to make sure all controls operate properly.

Table 4. Pressure Regulator Specification Pressures in Inches WC.

Model	Type of Gas	Nominal Inlet Pressure Range	Outlet Pressure	
			Nominal Factory Outlet Setting	Adjustment Setting Range
			Full Rate	Full Rate
Standard-opening	Natural	5.0 - 7.0	3.5	3.0 - 5.0
	LP	12.0 - 14.0	10.0	8.0 - 12.0

Table 5. Pressure Regulator Specification Pressures in kPa.

Model	Type of Gas	Nominal Inlet Pressure Range	Outlet Pressure	
			Nominal Factory Outlet Setting	Adjustment Setting Range
			Full Rate	Full Rate
Standard-opening	Natural	1.2 - 1.7	0.9	0.7 - 1.2
	LP	2.9 - 3.9	2.7	2.0 - 3.0

MAINTENANCE

WARNING

FIRE OR EXPLOSION HAZARD CAN CAUSE PROPERTY DAMAGE, SEVERE INJURY, OR DEATH
 Improper cleaning or reassembly can cause gas leakage. When cleaning, be sure that the control is reassembled properly and perform gas leak test.

Regular preventive maintenance is important in applications such as commercial cooking, agricultural and industrial operations that place a heavy load on system controls because:

- In many such applications, particularly commercial cooking, the equipment operates 100,000 to 200,000 cycles per year. Such heavy cycling can wear out the gas control in one to two years.
- Exposure to water, dirt, chemicals and heat can damage the gas control and shut down the control system.

The maintenance program should include regular checkout of the gas control; see Startup and Checkout section. To check out the control system, see the appliance manufacturer literature. Maintenance frequency must be determined individually for each application. Some considerations are:

- *Cycling frequency.* Appliances that may cycle 100,000 times annually should be checked monthly.
- *Intermittent use.* Appliances that are used seasonally should be checked before shutdown and again before the next use.
- *Consequence of unexpected shutdown.* Where the cost of an unexpected shutdown would be high, the system should be checked more often.
- *Dusty, wet or corrosive environment.* Since these environments can cause the gas control to deteriorate more rapidly, the system should be checked more often.

If the gas control will be exposed to high ammonia conditions, e.g., those used in greenhouses or animal barns, contact your Resideo sales representative to request a gas control with corrosion resistant construction. The gas control should be replaced if:

- It does not perform properly during checkout or troubleshooting.
- The gas control knob is hard to turn or push down or it fails to pop back up when released.
- The gas control is likely to have operated for more than 200,000 cycles.

SERVICE

WARNING

FIRE OR EXPLOSION HAZARD CAN CAUSE PROPERTY DAMAGE, SEVERE INJURY OR DEATH
 Do not disassemble the gas control; it contains no replaceable components. Attempted disassembly or repair can damage the gas control.

CAUTION

Do not apply a jumper across or short the valve coil terminals. Doing so can burn out the heat anticipator in the thermostat or damage the electronic module.

IF MAIN BURNER WILL NOT COME ON WITH CALL FOR HEAT

1. Make sure the gas control knob is in the ON position.
2. Adjust the thermostat several degrees above room temperature.
3. Using an ac voltmeter, check for voltage at the gas control.
 - If pilot lights, measure across MV/PV and MV.
 - If pilot does not light, measure across MV/PV and PV before safety lockout occurs.
4. If voltage is not present, check control circuit for proper operation.
5. If proper control circuit voltage is present, replace gas control.

INSTRUCTIONS TO THE HOMEOWNER (FOR YOUR SAFETY, READ BEFORE OPERATING)

⚠ WARNING

FIRE OR EXPLOSION HAZARD CAN CAUSE PROPERTY DAMAGE, SEVERE INJURY, OR DEATH

Follow these warnings exactly:

1. Pilot flame is lit automatically. Do not light the pilot flame manually.
2. Before lighting pilot burner flame, smell around the appliance for gas. Be sure to smell next to the floor because LP gas is heavier than air.
3. IF YOU SMELL GAS:
 - Turn off the gas supply at the appliance service valve. On LP gas systems, turn off gas supply at the gas tank.
 - Do not light any appliances in the house.
 - Do not touch electrical switches or use the phone.
 - Leave the building and use a neighbor's phone to call your gas supplier.
 - If you can not reach your gas supplier, call the fire department.
4. Do not force the gas control knob. Use only your hand to push down or turn the gas control knob. Never use any tools. If the gas control knob will not operate by hand, call a qualified service technician to replace the gas control. Force or attempted repair can result in a fire or explosion.
5. Call a qualified service technician to replace the gas control if it has been flooded with water.
6. Replace the gas control in the event of any physical damage, tampering, bent terminals, missing or broken parts, stripped threads, or evidence of exposure to heat.

IMPORTANT

Follow the operating instructions provided by the manufacturer of your heating appliance. The information below will be of assistance in a typical gas control application, but the specific controls used and the procedures outlined by the manufacturer or your appliance may differ and require special instructions.

TO TURN ON THE APPLIANCE

STOP: READ THE WARNINGS ABOVE.

The pilot flame is lit automatically. *Do not attempt to manually light the pilot.* If the appliance does not turn on when the thermostat is set several degrees above room temperature, follow these instructions:

1. Set the thermostat to its lowest setting to reset the safety control.
2. Disconnect all electric power to the appliance.
3. Remove the gas control access panel.
4. Push in the gas control knob slightly and turn clockwise to OFF.
5. Wait five minutes to clear out any unburned gas. If you then smell gas, STOP! Follow step 3 in the Warning in the Instructions To The Homeowner section. If you do not smell gas, continue with the next step.
6. Turn the gas control knob counterclockwise to ON.
7. Replace the gas control access panel.
8. Reconnect all electric power to the appliance.
9. Set the thermostat to the desired setting.
10. If the appliance does not turn on, set the gas control knob to OFF and contact a qualified service technician for assistance.

TURNING OFF THE APPLIANCE

VACATION SHUTDOWN—Set the thermostat to the desired room temperature while you are away.

COMPLETE SHUTDOWN—Push in the gas control knob slightly and turn clockwise to OFF. Do not force. Appliance will completely shut off. Follow the Instructions to the Homeowner above to resume normal operation.



Resideo Technologies, Inc.
1985 Douglas Drive North, Golden Valley, MN 55422
1-800-468-1502

www.resideo.com 69-0838-01 M.S. 06-20 | Printed in United States