



# SV9540; SV9640 SmartValve™ System Controls

## INSTALLATION INSTRUCTIONS

### APPLICATION

The SV9540; SV9640 SmartValve™ System Controls combine gas flow control and electronic intermittent pilot sequencing functions into a single unit. The low voltage igniter, flame sensor and pilot burner are supplied by the Q3450 or Q3480 Pilot Hardware. Provides all gas ignition safety functions by controlling gas flow, ignition source, and a 120 Vac or 240 Vac combustion air blower. The control also monitors the appliance airflow proving switch and limit string to assure proper appliance operation. Provides prepurge, postpurge, timed trial for pilot ignition, with 100 percent shutoff and continuous retry. Diagnostic LED indicates system status.

This control communicates directly with the ST9160 Electronic Fan Timer (EFT) in typical forced warm air furnace applications. It also interfaces with the 208907 Terminal Board, providing compatibility with power stealing thermostats. Or, it directly interfaces with the appropriate power supplies and a system thermostat for additional appliance applications. When controlled directly by a thermostat, the control does not provide a postpurge function, as power to the control is removed when the thermostat call for heat ends.

The SV9540; SV9640 system is suitable for a wide range of fan assisted combustion gas-fired appliances including furnaces, rooftop furnaces, boilers, unit heaters, infrared heaters, water heaters and commercial cooking appliances. The specific application of the SmartValve System is the responsibility of the appliance manufacturer. See Table 1 for temperature ranges and regulator types.

### SPECIFICATIONS



#### CAUTION

The SV9540; SV9640 provide direct replacement only. Use the Y8610 to convert standing pilot systems to electronic ignition systems.

**Table 1. Model Number Suffix Letter Designation.**

Model No. Suffix Letter	Ambient Temperature Range	Pressure Regulator Type
H	0°F to 175°F (-18°C to +79°C)	Slow-opening
M	-40°F to 175°F (-40°C to +79°C)	Standard
P	40°F to 175°F (-40°C to +79°C)	Step-opening

#### Body Pattern:

SV9540: Straight through with 1/2 in. inlet and 1/2 in. outlet; or 1/2 in. NPT inlet and 1/2 in. inverted flare outlet.

SV9640: Straight through with 1/2 in. inlet and 1/2 in. outlet, 1/2 in. inlet and 3/4 in. outlet, or 3/4 in. inlet and 3/4 in. outlet.

#### Electrical Ratings:

System Transformer:

SV9540: 40 VA minimum NEMA rated.

SV9640: 40 VA minimum NEMA rated.

NOTE: Larger system transformer may be required for specific applications.

#### Voltage and Frequency:

24 Vac, 60 Hz; 50 Hz models available.

#### Output Ratings:

Igniter Load: 1.5A maximum.

Induced Draft Motor Load: 2.5A Full Load, 10A

Locked Rotor at 120 Vac; 1.75A Full Load, 5A

Locked Rotor at 240 Vac.

#### Current at 24 Vac:

24V Thermostat: See Table 2.



**Table 2. Thermostat Current (Run Mode); with control connected directly to thermostat.**

Model	24 Vac, 60 Hz
SV9540	0.25A
SV9640	0.25A

**Prepurge Time (Factory-set):**

3, 15, 30 or 45 seconds, depending on model.

**Trial for Ignition:**

90 seconds.

**Postpurge Time (Factory-set):**

5 seconds; this is not available when the SmartValve System Control is connected directly to the thermostat.

**Retry Delay:**

5 minutes.

**Flame Failure Response Time:**

1.6 seconds maximum at 2 μ A.

**Capacity:**

See Table 3.

**Conversion:**

Use conversion factors in Table 4 to convert capacities for other gases.

**Regulation Range (Btuh);**

**SV9540 with 1/2 in. NPT Outlet:**

Natural Gas:

Minimum: 20,000.

Maximum: 200,000.

LP Gas:

Minimum: 40,000.

Maximum: 200,000.

**SV9540 with 1/2 in. Inverted Flare Outlet:**

Natural Gas:

Minimum: 20,000.

Maximum: 180,000.

LP Gas:

Minimum: 40,000.

Maximum: 180,000.

**SV9640 (3/4 in. x 3/4 in.):**

Natural Gas:

Minimum: 30,000.

Maximum: 415,000.

LP Gas:

Minimum: 30,000.

Maximum: 415,000

**Natural-LP Gas Conversion Kits:**

Natural Gas to LP:

393691 Conversion Kit.

LP to Natural Gas:

394588 Conversion Kit.

**IMPORTANT**

*SV9540P; SV9640P CANNOT be field-converted to LP or natural gas.*

**Pipe Adapters:**

Angle and straight adapters available for 3/8-, 1/2- and 3/4-in. pipe. See Table 5. Flange kits include one flange with attached O-ring, four mounting screws, a 9/64 in. hex wrench and instructions.

**Approvals:**

International Approval Services (IAS):  
Design Certified C2030025.

**Table 3. Capacity<sup>b</sup> of SV9540; SV9640.**

Model	Size (Inlet x Outlet) (in.)	Capacity (at 1 in. wc pressure drop <sup>a,c</sup> )	Minimum Regulated Capacity	Maximum Regulated Capacity
SV9540	1/2 x 1/2 NPT	150 ft <sup>3</sup> /hr (4.2 m <sup>3</sup> /hr)	20 ft <sup>3</sup> /hr (0.6 m <sup>3</sup> /hr)	200 ft <sup>3</sup> /hr (5.7 m <sup>3</sup> /hr)
	1/2 NPT x 1/2 inverted flare	130 ft <sup>3</sup> /hr (3.7 m <sup>3</sup> /hr)	20 ft <sup>3</sup> /hr (0.6 m <sup>3</sup> /hr)	180 ft <sup>3</sup> /hr (5.1 m <sup>3</sup> /hr)
SV9640	1/2 x 1/2	240 ft <sup>3</sup> /hr (6.8 m <sup>3</sup> /hr)	30 ft <sup>3</sup> /hr (0.8 m <sup>3</sup> /hr)	340 ft <sup>3</sup> /hr (9.6 m <sup>3</sup> /hr)
	1/2 x 3/4	270 ft <sup>3</sup> /hr (7.6 m <sup>3</sup> /hr)	30 ft <sup>3</sup> /hr (0.8 m <sup>3</sup> /hr)	370 ft <sup>3</sup> /hr (10.5 m <sup>3</sup> /hr)
	3/4 x 3/4	300 ft <sup>3</sup> /hr (8.5 m <sup>3</sup> /hr)	30 ft <sup>3</sup> /hr (0.8 m <sup>3</sup> /hr)	415 ft <sup>3</sup> /hr (11.8 m <sup>3</sup> /hr)

<sup>a</sup> Capacity based on 1000 Btu/feet<sup>3</sup>, 0.64 specific gravity natural gas at 1 in. wc pressure drop (37.3 MJ/meter<sup>3</sup>, 0.64 specific gravity natural gas at 0.25 kPa pressure drop).

<sup>b</sup> Capacity is reduced by 5 percent with the use of outlet screen.

<sup>c</sup> Valves are guaranteed at only 77 percent of the rating.

**Table 4. Gas Capacity Conversion Factor.**

Gas	Specific Gravity	Multiply Listed Capacity By
Manufactured	0.60	0.516
Mixed	0.70	0.765
Propane	1.53	1.62

**Table 5. Adapter (Flange) Part Numbers.**

Inlet/Outlet Pipe Size	Flange Type	Part No. <sup>a,b</sup>	
		Without Hex Wrench	With Hex Wrench
3/8 in. NPT	Straight	393690-1	393690-11
	Elbow	393690-2	393690-12
1/2 in. NPT	Straight	393690-6	393690-16
	Elbow	393690-3	393690-13
3/4 in. NPT	Straight	393690-4	393690-14
	Elbow	393690-5	393690-15

<sup>a</sup> Flange kits include one flange, one O-ring and four mounting screws.

<sup>b</sup> Do not use flanges on control models with 3/4 in. inlet and 3/4 in. outlet. On models with 1/2 in. inlet and 3/4 in. outlet, use flanges only on the 1/2 in. inlet side.

## PLANNING THE INSTALLATION



### WARNING

**FIRE OR EXPLOSION HAZARD CAN CAUSE PROPERTY DAMAGE, SEVERE INJURY, OR DEATH**

Follow these warnings exactly:

1. Plan the installation as outlined below.
2. Plan for frequent maintenance as described in the Maintenance section.

When intermittent pilot systems are used on central heating equipment in barns, greenhouses, and commercial properties and on heating appliances such as commercial cookers, agricultural equipment, industrial heating equipment and pool heaters, heavy demands are made on the controls. Special steps may be required to prevent nuisance shutdowns and control failure due to frequent cycling, severe environmental conditions related to moisture, corrosive chemicals, dust or excessive heat. These applications require Resideo Engineering review; contact your Sales Representative for assistance.

Review the following conditions that can apply to your specific installation and take the precautionary steps suggested.

### Frequent Cycling

This control is designed for use on appliances that typically cycle three to four times an hour only during the heating season. In year-around applications with greater cycling rates, the control can wear out more quickly. Perform a monthly check-out.

## Water or Steam Cleaning

If a control gets wet, replace it. If the appliance is likely to be cleaned with water or steam, protect (cover) the control and wiring from water or steam flow. Mount the control high enough above the bottom of the cabinet so it does not get wet during normal cleaning procedures.

## High Humidity or Dripping Water

Dripping water can cause the control to fail. Never install an appliance where water can drip on the control.

In addition, high ambient humidity can cause the control to corrode and fail. If the appliance is in a humid atmosphere, make sure air circulation around the control is adequate to prevent condensation. Also, regularly check out the system.

## Corrosive Chemicals

Corrosive chemicals can attack the control, eventually causing a failure. If chemicals are used for routine cleaning, avoid contact with the control. Where chemicals are suspended in air, as in some industrial or agricultural applications, protect the control with an enclosure.

## Dust or Grease Accumulation

Heavy accumulations of dust or grease can cause the control to malfunction. Where dust or grease can be a problem, provide covers for the control to limit contamination.

## Heat

Excessively high temperatures can damage the control. Make sure the maximum ambient temperature at the control does not exceed the rating of the control. If the appliance operates at very high temperatures, use insulation, shielding, and air circulation, as necessary, to protect the control. Proper insulation or shielding should be provided by the appliance manufacturer; verify proper air circulation is maintained when the appliance is installed.

## INSTALLATION

### When Installing this Product...

1. Read these instructions carefully. Failure to follow them could damage the product or cause a hazardous condition.
2. Check the ratings given in the instructions and on the product to make sure the product is suitable for your application.
3. Installer must be a trained, experienced service technician.
4. After installation is complete, check out product operation as provided in these instructions.

**⚠ WARNING**

**FIRE OR EXPLOSION HAZARD CAN CAUSE PROPERTY DAMAGE, SEVERE INJURY OR DEATH**  
Follow these warnings exactly:

1. Disconnect power supply before wiring to prevent electrical shock or equipment damage.
2. To avoid dangerous accumulation of fuel gas, turn off gas supply at the appliance service valve before starting installation, and perform Gas Leak Test after completion of installation.
3. Do not bend pilot tubing at ignition system control or pilot burner after compression fitting is tightened, or gas leakage at the connection can result.
4. Always install a sediment trap in gas supply line to prevent contamination of ignition system control.

**⚠ WARNING**

**LINE VOLTAGE CAN CAUSE PROPERTY DAMAGE, SEVERE INJURY OR DEATH.**

Never apply a jumper across or short any of the terminals in the SV9540; SV9640 wiring harness. This can damage the system transformer or the control.

Follow the appliance manufacturer instructions if available; otherwise, use these instructions as a guide.

## Converting Ignition System Control from Natural Gas to LP Gas Application (or LP Gas to Natural Gas Application)

**⚠ WARNING**

**FIRE OR EXPLOSION HAZARD CAN CAUSE PROPERTY DAMAGE, SEVERE INJURY OR DEATH**  
Do NOT attempt to convert step-opening models (SV9540P/SV9542P; SV9640P/SV9642P).

Always change the main and pilot burner orifices when converting from natural to LP gas or from LP to natural gas. Follow appliance manufacturer specifications and instructions carefully to assure proper appliance conversion.

Ignition system controls are factory-set for natural (and manufactured) or LP gas. Do not attempt to use an ignition system control set for natural (manufactured) gas on LP gas, or an ignition system control set for LP gas on natural (manufactured) gas.

Ignition system controls with standard or slow opening regulators (SV9540M,H; SV9640M,H) can be converted from one gas to the other with a conversion kit (ordered separately). Order part no. 393691 to convert from natural (manufactured) to LP gas; order part no. 394588 to convert from LP to natural (manufactured) gas.

**IMPORTANT**

*Ignition system controls with step-opening regulators (SV9540P; SV9640P) CANNOT be field-converted to LP or natural gas.*

## Install Adapters To Control

If adapters are being installed on the control, mount them as follows:

## Flanges

1. Choose the appropriate flange for your application.
2. Remove the seal over the ignition system control inlet or outlet.
3. Make sure that the O-ring is fitted in the groove of the flange. If the O-ring is not attached or missing, do not use the flange.
4. With the O-ring facing the ignition system control, align the screw holes on the ignition system control with the holes in the flange. Insert and tighten the screws provided with the flange. See Fig. 1. Tighten the screws to 25 inch-pounds of torque to provide a gas-tight seal.

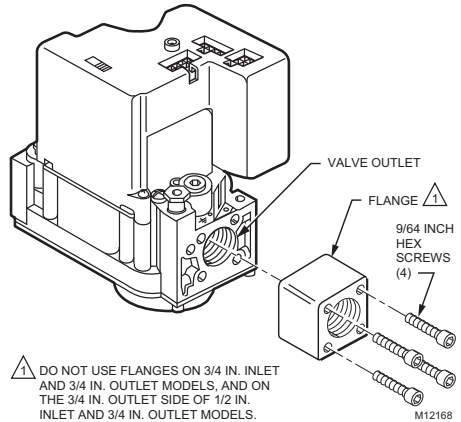

**Fig. 1. Firmly fasten flange to valve, but do not overtighten screws.**

## Bushings

1. Remove the seal over the ignition system control inlet or outlet.
2. Apply a moderate amount of good quality pipe compound to the bushing, leaving two end threads bare. On an LP installation, use compound resistant to LP gas. Do not use Teflon tape.
3. Insert the bushing in the ignition system control and carefully thread the pipe into the bushing until tight.

Complete the instructions below for installing the piping, installing the control, connecting the pilot tubing and wiring. Make sure the leak test you perform on the control after completing the installation includes leak testing the adapters and screws. If you use a wrench on the valve after the flanges are installed, use the wrench only on the flange, not on the control. See Fig. 5.

## Location

The SV9540; SV9640 are mounted in the appliance vestibule on the gas manifold.

**IMPORTANT**

*These ignition system controls are shipped with protective seals over the inlet and outlet tap-pings. Do not remove the seals until ready to connect the piping.*

## Install Piping to Control

All piping must comply with local codes and ordinances or with the National Fuel Gas Code (ANSI Z223.1 NFPA No. 54), whichever applies. Tubing installation must comply with approved standards and practices.

1. Use new, properly reamed pipe free from chips. If tubing is used, make sure the ends are square, deburred and clean. All tubing bends must be smooth and without deformation.
2. Run pipe or tubing to the ignition system control. If tubing is used, obtain a tube-to-pipe coupling to connect the tubing to the ignition system control.
3. Install a sediment trap in the supply line to the ignition system control. See Fig. 2.

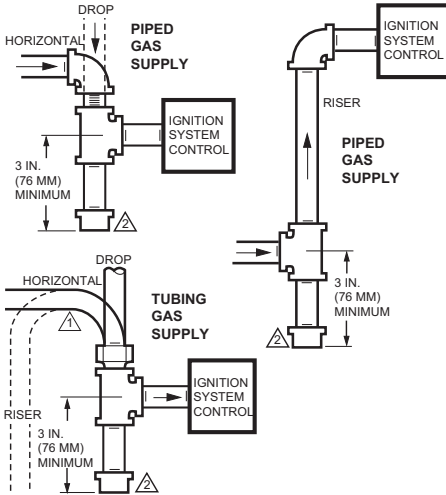

⚠ ALL BENDS IN METALLIC TUBING SHOULD BE SMOOTH.

⚠ CAUTION: SHUT OFF THE MAIN GAS SUPPLY BEFORE REMOVING THE END CAP TO PREVENT GAS FROM FILLING THE WORK AREA. TEST FOR GAS LEAKAGE WHEN INSTALLATION IS COMPLETE.

M3343A

Fig. 2. Sediment trap installation.

## Install Control

1. This ignition system control can be mounted 0 to 90 degrees in any direction, including vertically, from the upright position of the ignition system control switch.
2. Mount the control so the gas flow is in the direction of the arrow on the bottom of the ignition system control.

3. Thread the pipe the amount shown in Table 6 for insertion into ignition system control or adapters. Do not thread pipe too far. Valve distortion or malfunction can result if the pipe is inserted too deeply.

Table 6. NPT Pipe Thread Length (in.).

Pipe Size	Thread Pipe this Amount	Maximum Depth Pipe can be Inserted into Control
3/8	9/16	3/8
1/2	3/4	1/2
3/4	13/16	3/4

4. Apply a moderate amount of good quality pipe compound (do not use Teflon tape) only to the pipe, leaving two end threads bare. On LP installations, use a compound resistant to LP gas. See Fig. 3.

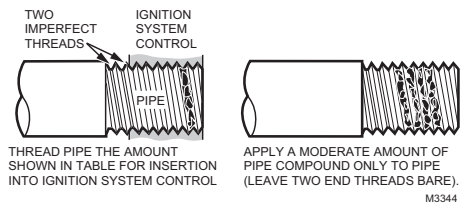

Fig. 3. Use moderate amount of pipe compound.

5. Remove the seals over the ignition system control inlet and outlet, if necessary.
6. Connect the pipe to the ignition system control inlet and outlet. Use a wrench on the square ends of the ignition system control. If a flange is used, place the wrench on the flange rather than on the ignition system control. Refer to Fig. 4 and 5.

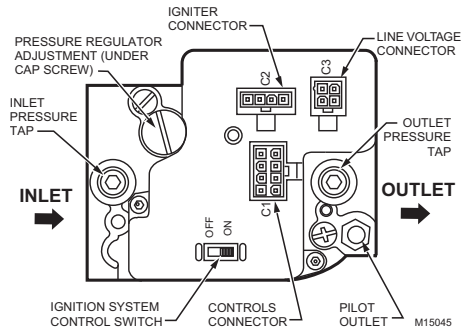

Fig. 4. Top view of ignition system control.

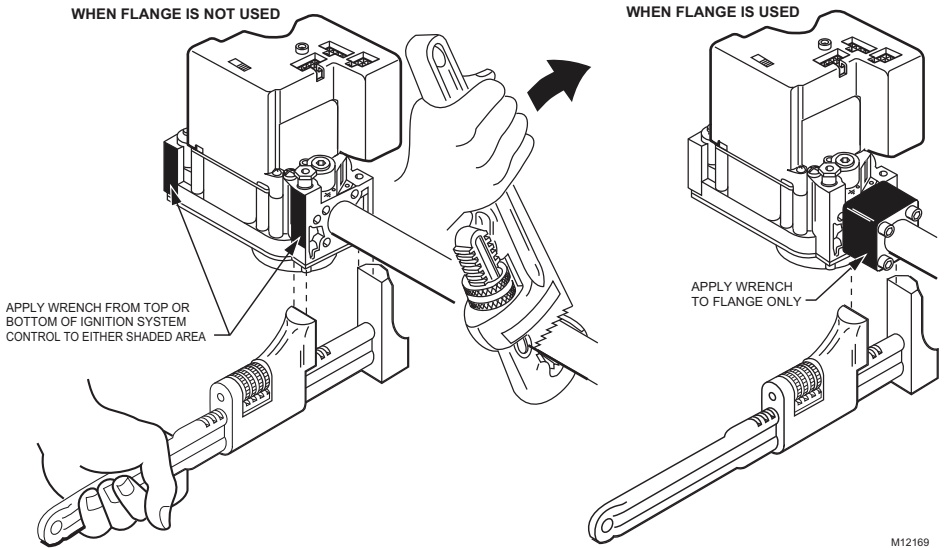

Fig. 5. Proper use of wrench on ignition system control with and without flanges.

### Connect Pilot Gas Tubing

1. Cut tubing to the desired length and bend as necessary for routing to the pilot burner. Do not make sharp bends or deform the tubing. Do not bend the tubing at the ignition system control after the compression nut is tightened, because this can result in gas leakage at the connection.
2. Square off and remove burrs from the end of the tubing.
3. Unscrew the brass compression fitting from the pilot outlet (Fig. 4). Slip the fitting over the tubing and slide out of the way. See Fig. 6
4. Push the tubing into the pilot gas tapping on the outlet end of the control until it bottoms. While holding the tubing all the way in, slide the fitting into place and engage the threads—turn until finger tight. Then tighten one more turn with a wrench. Do not overtighten.
5. Connect the other end of the tubing to the pilot burner according to the instructions supplied with Q3450/Q3480.

NOTE: The pilot tubing provides the SmartValve System flame sense current path. Make sure the connections are clean and tight for proper operation.

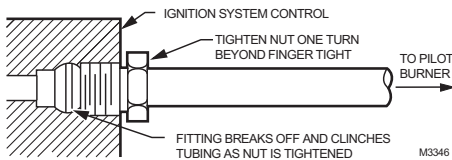

Fig. 6. Always use new compression fitting.

### Wiring

Follow the wiring instructions furnished by the appliance manufacturer, if available, or use the general instructions provided below. When these instructions differ from the appliance manufacturer, follow the appliance manufacturer instructions.

All wiring must comply with applicable electrical codes and ordinances.

Disconnect power supply before making wiring connections to prevent electrical shock or equipment damage.

1. Check the power supply rating on the ignition system control and make sure it matches the available supply. The system transformer should be NEMA rated for 40 VA or larger. An appliance system power review is recommended. Install a transformer, thermostat and other controls, as required.
2. With 120 Vac power supply, connect the 120V hot lead to L1 on the ST9160 or 208907 Terminal Board. With 240 Vac power supply, there must be 120 Vac potential between L1 and appliance chassis.
3. Appliance chassis must have reliable connection to earth ground.
4. Connect control circuit to the ignition system control using the keyed connector. See Fig. 7 through 10.

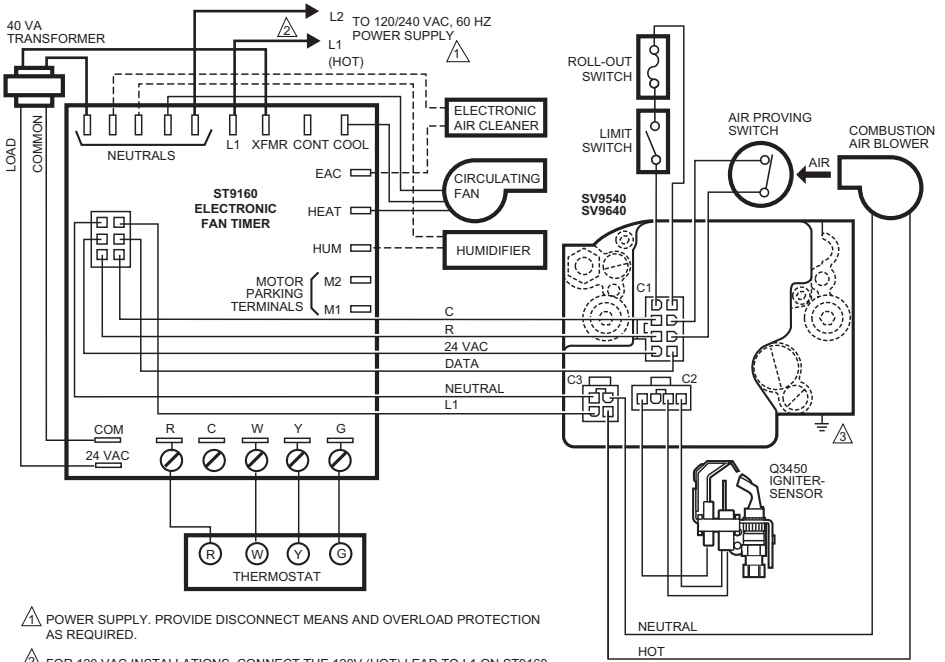

- ⚠ POWER SUPPLY. PROVIDE DISCONNECT MEANS AND OVERLOAD PROTECTION AS REQUIRED.
- ⚠ FOR 120 VAC INSTALLATIONS, CONNECT THE 120V (HOT) LEAD TO L1 ON ST9160. FOR 240 VAC INSTALLATIONS, THERE MUST BE 120 V BETWEEN L1 AND APPLIANCE CHASSIS.
- ⚠ APPLIANCE CHASSIS MUST HAVE RELIABLE CONNECTION TO EARTH GROUND.

M12176

**Fig. 7. SV9540; SV9640 typical wiring connections in fan assisted warm air furnace with ST9160 Electronic Fan Timer.**

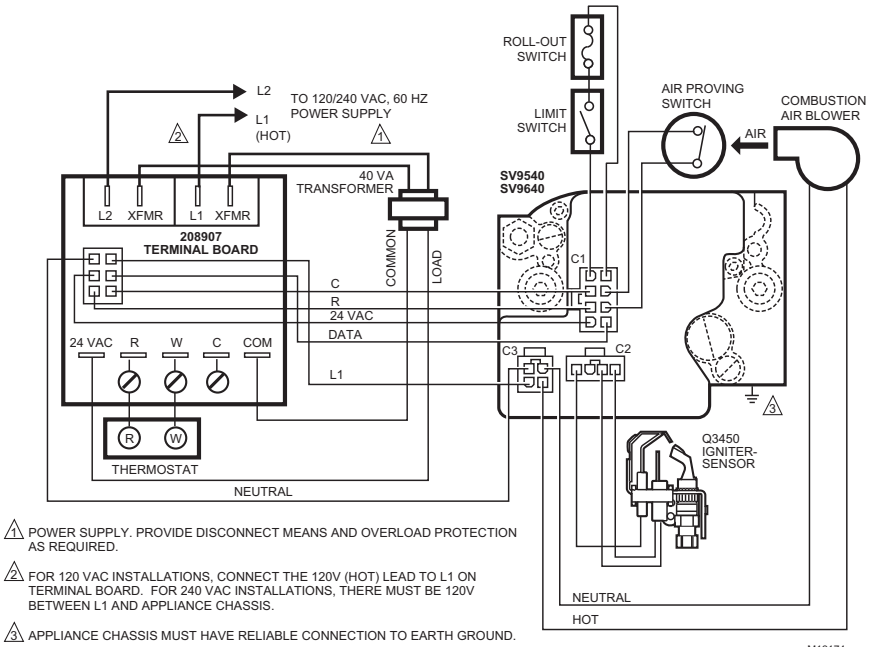

M12174

Fig. 8. SV9540; SV9640 typical wiring connections with 208907 Terminal Board.

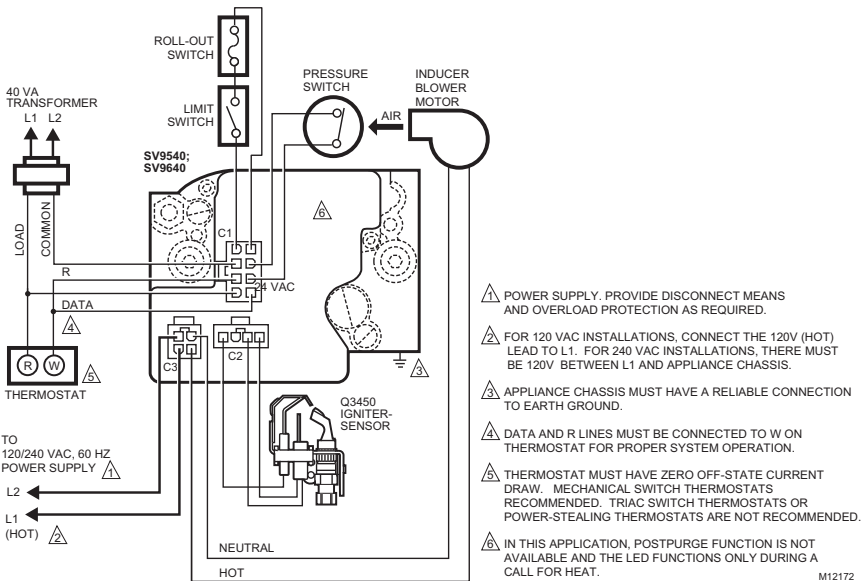

M12172

Fig. 9. SV9540; SV9640 typical wiring connections direct to the system thermostat.



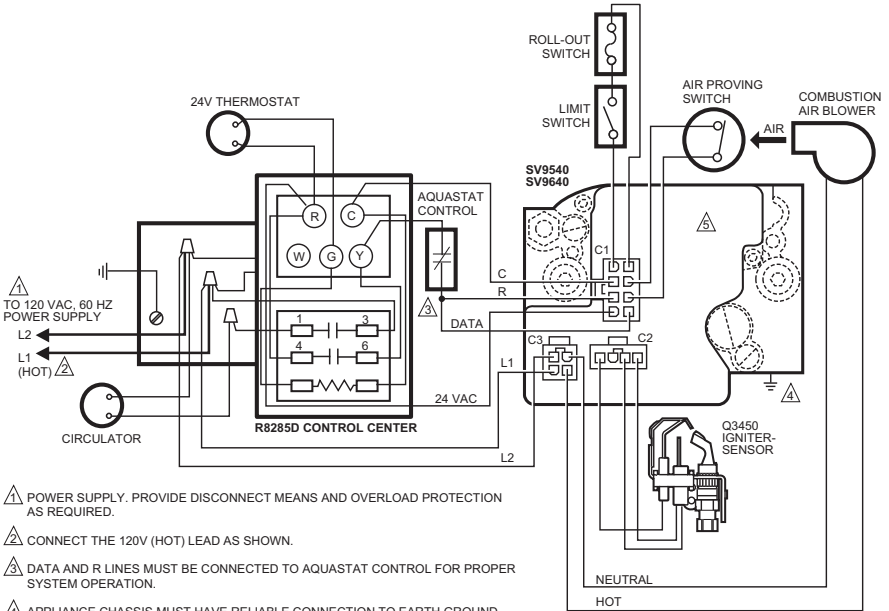

- ⚠ POWER SUPPLY. PROVIDE DISCONNECT MEANS AND OVERLOAD PROTECTION AS REQUIRED.
- ⚠ CONNECT THE 120V (HOT) LEAD AS SHOWN.
- ⚠ DATA AND R LINES MUST BE CONNECTED TO AQUASTAT CONTROL FOR PROPER SYSTEM OPERATION.
- ⚠ APPLIANCE CHASSIS MUST HAVE RELIABLE CONNECTION TO EARTH GROUND.
- ⚠ IN THIS APPLICATION, POSTPURGE FUNCTION IS NOT AVAILABLE AND THE LED FUNCTIONS ONLY DURING A CALL FOR HEAT.

M12398

Fig. 10. SV9540; SV9640 typical boiler wiring diagram.

## STARTUP AND CHECKOUT

### Ignition System Control Switch Settings

Ignition system control switch settings are as follows:

- OFF prevents pilot and main gas flow through the ignition system control.
- ON permits gas to flow through the control body. At the appropriate time in the appliance operation, main gas can flow to the main burner.

**NOTE:** Controls are shipped with the ignition system control switch in the ON position. If the appliance is operated with the ignition system control switch in the OFF position, the system will respond as if the air proving switch is stuck in the no airflow position.

### Turn on Main Burner

Follow the instructions provided by the appliance manufacturer or turn up the thermostat to call for heat.

### Perform Gas Leak Test

**⚠ WARNING**  
**FIRE OR EXPLOSION HAZARD CAN CAUSE PROPERTY DAMAGE, SEVERE INJURY OR DEATH**  
 Check for gas leaks with soap and water solution any time work is done on a gas system.

### ⚠ CAUTION

Do not spray soap and water solution on the SmartValve housing. Do not use an excessive amount of soap and water solution to perform the gas leak test. These can damage the control.

### Gas Leak Test

1. Paint pipe connections upstream of the ignition system control with rich soap and water solution. Bubbles indicate a gas leak.
2. If a leak is detected, tighten the pipe connections.
3. Stand clear of the main burner while lighting to prevent injury caused from hidden leaks that could cause flashback in the appliance vestibule. Light the main burner.
4. With the main burner in operation, paint the pipe joints (including adapters) and the control inlet and outlet with rich soap and water solution.
5. If another leak is detected, tighten the adapter screws, joints, and pipe connections.
6. Replace the part if a leak cannot be stopped.

### Check and Adjust Pilot Flame

The pilot flame should envelop 3/8 to 1/2 in. (10 to 13 mm) of the tip of the flame rod. It should also be in continual contact with the ground electrode. See Fig. 11. If the pilot flame is small or lazy, or does not touch the ground electrode, the inlet gas pressure may be too low, or the pilot orifice may be partially clogged. Check and repair as necessary. If the pilot flame is hard and noisy, the inlet gas pressure may be too high. The ignition system control has a pilot adjustment mechanism to

reduce the pilot flow if necessary. The pilot adjustment is shipped at the full pilot gas flow rate. If pilot adjustment is necessary, proceed as follows:

1. Remove pilot adjustment cover screw. See Fig. 4.
2. Pilot adjustment is shipped at full flow rate. Turn the inner adjustment screw clockwise if the inlet pressure is too high. Turn the inner adjustment screw clockwise to decrease or counterclockwise to increase pilot flame.
3. Replace the cover screw after the adjustment to prevent gas leakage.

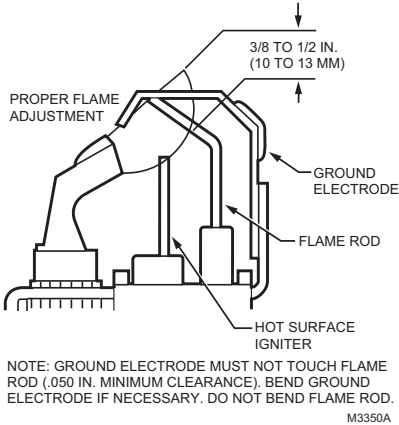

Fig. 11. Proper flame adjustment.

## Check and Adjust Gas Input and Burner Ignition

### ⚠ CAUTION

1. Do not exceed input rating stamped on appliance nameplate, or manufacturer's recommended burner orifice pressure for size orifice(s) used. Make certain primary air supply to main burner is properly adjusted for complete combustion. Follow instructions of appliance manufacturer.
2. IF CHECKING GAS INPUT BY CLOCKING GAS METER: Make certain there is no gas flow through the meter other than to the appliance being checked. Other appliances must remain off with the pilots extinguished (or that consumption must be deducted from the meter reading). Convert flow rate to Btuh as described in form 70-2602, Gas Controls Handbook, and compare to Btuh input rating on appliance nameplate.
3. IF CHECKING GAS INPUT WITH MANOMETER: Make sure the ignition system control is in the OFF position before removing outlet pressure tap plug to connect manometer (pressure gauge). Also move the ignition system control switch to the OFF position when removing the gauge and replacing the plug. Before removing inlet pressure tap plug, shut off gas supply at the manual valve in the gas piping to the appliance or, for LP, at the tank. Also shut off gas supply before disconnecting manometer and replacing plug. Repeat Gas Leak Test at plug with main burner operating.

NOTE: Check the inlet pressure before adjusting the pressure regulator.

1. Carefully check the main burner lightoff. Make sure that the main burner lights smoothly and that all ports remain lit.
2. Check the full rate manifold pressure listed on the appliance nameplate. Ignition system control full rate outlet pressure should match this rating.
3. With main burner operating, check the ignition system control flow rate using the meter clocking method or check pressure using a manometer connected to the outlet pressure tap on the ignition system control. See Fig. 4.
4. If necessary, adjust the pressure regulator to match the appliance rating. See Tables 7 and 8 for factory-set nominal outlet pressure and adjustment range.
  - a. Remove the pressure regulator adjustment cap screw.
  - b. Using a screwdriver, turn the inner adjustment screw clockwise to increase or counterclockwise to decrease the gas pressure to the burner.
  - c. Always replace the cap screw and tighten firmly to prevent gas leakage.
5. If the desired outlet pressure or flow rate cannot be achieved by adjusting the ignition system control, check the ignition system control inlet pressure using a manometer at the ignition system control inlet pressure tap. If the inlet pressure is in the nominal range (see Tables 7 and 8), replace the ignition system control. Otherwise, take the necessary steps to provide proper gas pressure to the control.

NOTE: If the burner firing rate is above 150,000 Btu/h on SV9540 models (see Table 3 for SV9640 capacities), it may not be possible to deliver the desired outlet pressure. This is an application issue, not a control failure. Take whatever steps are required to correct the situation.

6. STEP-OPENING PRESSURE REGULATORS ONLY. Carefully check the burner lightoff at step pressure. Make sure the burner lights smoothly and without

flashback to the orifice. Make sure all ports remain lit. Cycle the burner several times, allowing at least 60 seconds between cycles for the regulator to resume the step function. Repeat after allowing the burner to cool. Readjust the full rate outlet pressure, if necessary, to improve lightoff characteristics.

**Table 7. Pressure Regulator Specification Pressures (in. wc).**

Model Type	Type of Gas	Nominal Inlet Pressure Range	Factory Set Nominal Outlet Pressure		Setting Range	
			Step	Full Rate	Step	Full Rate
Standard, Slow	NAT	5.0-7.0	—	3.5	—	3.0-5.0
	LP	12.0-14.0	—	10.0	—	8.0-12.0
Step	NAT	5.0-7.0	0.9	3.5	None	0.7-1.7
	LP	12.0-14.0	2.2	10.0	None	1.4-5.5

**Table 8. Pressure Regulator Specification Pressures (kPa).**

Model Type	Type of Gas	Nominal Inlet Pressure Range	Factory Set Nominal Outlet Pressure		Setting Range	
			Step	Full Rate	Step	Full Rate
Standard, Slow	NAT	1.2-1.7	—	0.9	—	0.7-1.2
	LP	2.9-3.9	—	2.5	—	2.0-3.0
Step	NAT	1.2-1.7	0.2	0.9	None	0.17-0.48
	LP	2.9-3.9	0.5	2.5	None	1.4-1.37

## MAINTENANCE

### WARNING

**FIRE OR EXPLOSION HAZARD CAN CAUSE PROPERTY DAMAGE, SEVERE INJURY, OR DEATH**  
Do not attempt to take the control apart or clean it. Improper cleaning or reassembly can cause gas leakage.

Regular preventive maintenance is important in applications such as in the commercial cooking and agricultural and industrial industries that place a heavy load on system controls because:

- In many such applications, particularly commercial cooking, the equipment operates 100,000 to 200,000 cycles per year. Such heavy cycling can wear out the gas control in one to two years.
- Exposure to water, dirt, chemicals and heat can damage the gas control and shut down the control system.

The maintenance program should include regular check-out of the control as outlined in the Startup and Checkout section, and the control system as described in the appliance manufacturer literature.

Maintenance frequency must be determined individually for each application. Some considerations are:

- Cycling frequency. Appliances that may cycle 20,000 times annually should be checked monthly.
- Intermittent use. Appliances that are used seasonally should be checked before shutdown and again before the next use.
- Consequence of unexpected shutdown. Where the cost of an unexpected shutdown would be high, the system should be checked more often.
- Dusty, wet, or corrosive environment. Since these environments can cause the gas control to deteriorate more rapidly, the system should be checked more often.

The system should be replaced if:

- It does not perform properly on checkout or troubleshooting.
- The gas control is likely to have operated for more than 200,000 cycles.
- The control is wet or looks as if it has been wet.

## SERVICE

### WARNING

**FIRE OR EXPLOSION HAZARD CAN CAUSE PROPERTY DAMAGE, SEVERE INJURY OR DEATH**  
Do not disassemble the ignition system control; it contains no replaceable components. Attempted disassembly or repair can damage the ignition system control.

### CAUTION

1. Do not apply a jumper across or short any of the terminals in the SV9540; SV9640 wiring harness. Doing so can damage the system transformer or the system control.
2. After servicing, verify proper system operation.

#### **IMPORTANT**

*Allow 60 seconds after shutdown before re-energizing step-opening model to assure lightoff at step pressure.*

## Sequence of Operation

1. Make sure the ignition system control switch is in the ON position.
2. Follow the sequence of operation as shown in Fig. 12.

**SV9540; SV9640 INTERMITTENT PILOT SmartValve™  
SYSTEM CONTROL SEQUENCE OF OPERATION  
WITH ST9160 ELECTRONIC FAN TIMER OR 208907 TERMINAL BOARD**

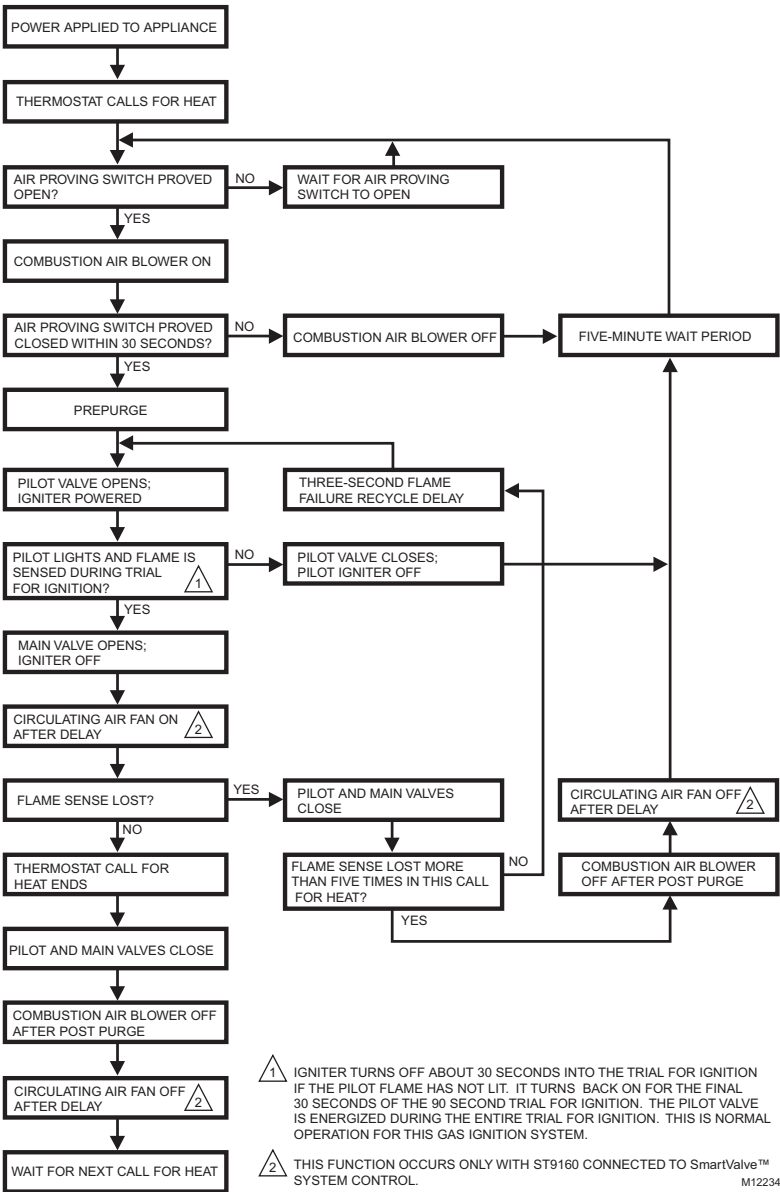

**Fig. 12. SV9540; SV9640 sequence of operation.**

# TROUBLESHOOTING

## Troubleshooting with LED Indicator Assistance

No cycling of appliance power or thermostat call for heat since appliance failure has occurred.



### WARNING

**LINE VOLTAGE POWER CAN CAUSE PRODUCT DAMAGE, SEVERE INJURY OR DEATH**

Only a trained, experienced service technician should perform this troubleshooting.

1. Check the system thermostat to make sure it is calling for heat. (Do not cycle the thermostat on and off at this time.)
2. Remove the appliance burner compartment door. Do not interrupt power to the SV9540; SV9640 by opening any electrically interlocked panels.
3. Observe the LED indicator on the SV9540; SV9640; check and repair system as noted in the following chart:

LED Status	Indicates	Check/Repair
Off	No power to system control.	<ol style="list-style-type: none"> <li>1. Line voltage input power at L1 and L2 connectors on ST9160 Electronic Fan Timer (EFT) or 208907 Terminal Board</li> <li>2. Low voltage (24V) power at 24 VAC and COM terminals on ST9160 or Terminal Board</li> <li>3. Fuse on ST9160 EFT, if provided.</li> <li>4. System wiring harness is in good condition and securely connected at both ends.</li> </ol>
Bright-Dim	<p>Normal Operation</p> <p>This indication shows whenever the system is powered, unless some abnormal event has occurred.</p>	Not Applicable
2 Flashes	<p>Airflow proving switch remains closed longer than 30 seconds after a call for heat begins.</p> <p>Combustion air blower is not energized until airflow proving switch opens.</p>	<ol style="list-style-type: none"> <li>1. Airflow proving switch stuck closed.</li> <li>2. Airflow proving switch miswired or jumpered.</li> </ol>
3 Flashes	<p>Airflow proving switch remains open longer than 30 seconds after combustion air blower energized.</p> <p>System goes into 5 minute delay period, with combustion air blower off. At the end of the 5 minute delay, another ignition cycle will begin.</p>	<ol style="list-style-type: none"> <li>1. Ignition system control switch must be in the ON position.</li> <li>2. Airflow proving switch operation, tubing, and wiring.</li> <li>3. Obstructions or restrictions in appliance air intake or exhaust flue system that prevent proper combustion airflow.</li> </ol>
4 Flashes	<p>Limit string is open.</p> <p>Combustion air blower is energized. If control system includes ST9160 Electronic Fan Timer, the heat speed circulating air fan will be energized until the limit string resets.</p>	<ol style="list-style-type: none"> <li>1. Open manual reset or auto reset burner rollout switch.</li> <li>2. Open high temperature or auxiliary limit switch.</li> <li>3. Limit and rollout switch wiring is in good condition and securely connected.</li> </ol>
5 Flashes	<p>Flame signal sensed out of proper sequence.</p> <p>Combustion air blower is energized. If control system includes ST9160 Electronic Fan Timer, the heat speed circulating air fan will be energized after the selected heat fan on delay.</p>	Flame at pilot burner.
6 Flashes	<p>System Lockout</p> <p>After 5 minute delay time, control system will reset and initiate a new ignition sequence, if the call for heat is still present.</p>	<ol style="list-style-type: none"> <li>1. Gas supply off or at too low pressure to operate appliance</li> <li>2. Damaged or broken HSI element</li> <li>3. Line voltage HOT leadwire not connected to L1 terminal on ST9160 or Terminal Board.</li> <li>4. Appliance not properly earth grounded.</li> <li>5. Flame sense rod contaminated or in incorrect location.</li> <li>6. Pilot burner located in incorrect position.</li> <li>7. Pilot burner leadwires are in good condition and properly connected.</li> </ol>

- After LED flash code analysis and appliance repair are complete, turn the thermostat below room temperature for 10 seconds; turn the thermostat above room temperature to initiate a new call for heat.
- Observe the ignition sequence, comparing it to the Sequence of Operation shown in Fig. 12. Allow the new ignition sequence to proceed until appliance lights or an abnormal or unexpected event is observed. See next section.

## Troubleshooting Without LED Indicator Assistance

Appliance power or thermostat call for heat has cycled since appliance failure occurred.



### WARNING

**LINE VOLTAGE POWER CAN CAUSE PRODUCT DAMAGE, SEVERE INJURY OR DEATH**

Only a trained, experienced service technician should perform this troubleshooting.

- Make sure the appliance power is on and any manually operated gas cock on the appliance is open.
- Remove appliance burner compartment door. Confirm that SV9540; SV9640 LED indicator is flashing in a "bright -dim" sequence.
- Make sure the ignition system control switch is in the ON position.
- Disconnect the system thermostat leadwires at the ST9160 EFT or the 208907 Terminal Board.
- Using alligator clips on a short jumper wire, jumper the R and W terminals on the EFT or Terminal Board.
- Observe the appliance operation, comparing it to the Sequence of Operation shown in Fig. 12. Allow the ignition sequence to proceed until the appliance lights or an abnormal or unexpected event is observed.
- Check the appliance as shown in the following table:

If	And	Check/Repair
Combustion air blower does not energize.	2 Flash code does not come on 30 seconds after call for heat starts.	1. Combustion air blower wiring 2. Combustion air blower
Combustion air blower does not energize.	2 Flash code does come on 30 seconds after call for heat starts.	1. Airflow proving switch stuck closed. 2. Airflow proving switch miswired or jumpered.
Combustion air blower is energized.	3 Flash code does not come on after 30 seconds.	Wait for the prepurge time to expire
3 Flash code comes on 30 seconds after combustion air blower is energized.	Combustion air blower turns off.	1. Ignition system control switch must be in the ON position. 2. Airflow proving switch stuck in open position. 3. Airflow proving switch tubing and wiring 4. Obstructions or restrictions in appliance air intake or exhaust flue system that prevent proper combustion air flow.
Prepurge time has expired.	HSI element does not glow red within 5 seconds.	1. Broken or damaged HSI element 2. Broken or damaged HSI element leadwires 3. SV9540; SV9640 failure to power HSI element.
HSI element is glowing red.	Pilot does not light during the 90 second trial for ignition.  NOTE: HSI element will turn off for approximately 25 seconds during the 90 second trial for ignition.	1. Pilot tubing not purged of air [Initiate another ignition sequence with the R-W jumper to clear pilot tubing more quickly] 2. Inlet gas pressure too low for proper appliance operation. 3. Pilot burner improperly positioned in airflow 4. Clogged or incorrect pilot orifice. 5. Combustion air blower moving pilot gas away from HSI element.
Pilot lights during trial for ignition.	Main gas does not flow.  If pilot flame is not sensed during trial for ignition, main valve will not open. System will shut off HSI element and pilot gas flow, go through a 5 minute delay period, then initiate another ignition trial.	1. Line voltage to L1 terminal of ST9160 or Terminal Board must be 120 volts with reference to appliance chassis. 2. Appliance must be reliably connected to earth ground. 3. Combustion air blower moving pilot flame away from pilot burner flame rod. 4. Inlet gas pressure too low for proper flame sensing. 5. Flame sense rod contaminated or in incorrect location. 6. Wiring between SV9540; SV9640 and pilot burner must be in good condition and properly connected.
Main burner lights.	Circulating air fan is not turned on after appropriate delay time (systems with ST9160 Electronic Fan Timer only).	1. Wiring between SV9540; SV9640 and ST9160 EFT. 2. Proper operation of ST9160 EFT.

If	And	Check/Repair
Main burner goes out before thermostat call for heat ends.	4 Flash code comes on.	1. Open manual reset or auto reset burner rollout switch. 2. Open high temperature or auxiliary limit switch. 3. Limit and rollout switch string wiring is in good condition and securely connecte.d
Main burner goes out before thermostat call for heat ends.	4 Flash code does not come on.	1. Intermittent wiring connection between SV9540; SV9640 and pilot burner. 2. Combustion air blower moving pilot flame away from pilot burner flame rod. 3. Airflow proving switch has opened. 4. Flame sense rod ceramic or leadwire overheated. 5. Gas flow supply reduced or interrupted.
5 Flash code comes on.		Flame at pilot burner.
6 Flash code comes on. After 5 minute delay time, control system will reset and initiate a new ignition sequence, if the call for heat is still present.		1. Gas supply off or at too low pressure to operate appliance 2. Damaged or broken HSI element 3. Line voltage to L1 terminal on ST9160 or Terminal Board must be 120 volts with reference to appliance chassis. 4. Appliance not properly earth grounded. 5. Flame sense rod contaminated or in incorrect location. 6. Pilot burner located in incorrect position. 7. Pilot burner leadwires in good condition and properly connected

## Instructions to the Homeowner

### WARNING

#### FIRE OR EXPLOSION HAZARD CAN CAUSE PROPERTY DAMAGE, SEVERE INJURY, OR DEATH

Follow these warnings exactly:

- Pilot flame is lit automatically. Do not light the pilot flame manually.
- Before lighting the pilot burner flame, smell around the appliance for gas. Be sure to smell next to the floor because LP gas is heavier than air.
- IF YOU SMELL GAS:
  - Turn off the gas supply at the appliance service valve. On LP gas systems, turn off the gas supply at the gas tank.
  - Do not light any appliances in the house.
  - Do not touch electrical switches or use the phone.
  - Leave the building and use a neighbor's phone to call your gas supplier.
  - If you cannot reach your gas supplier, call the fire department.
- The ignition system control must be replaced in event of any physical damage, tampering, bent terminals, missing or broken parts, stripped threads, or evidence of exposure to heat.

### IMPORTANT

*Follow the operating instructions provided by the manufacturer of your heating appliance. The information below describes a typical ignition system control application, but the specific controls used and the procedures outlined by the manufacturer of your appliance can differ, requiring special instructions.*

## STOP: Read the Warnings Above.

The pilot flame is lit automatically. If the appliance does not turn on when the thermostat is set several degrees above room temperature, follow these instructions:

- Set the thermostat to its lowest setting to reset the safety control.
- Disconnect all electric power to the appliance.
- Remove the ignition system control access panel.
- Move the ignition system control switch to the OFF position.
- Wait five minutes to clear out any unburned gas. If you then smell gas, STOP! Follow Step 3 in the Warning above. If you do not smell gas, continue with the next step.
- Move the ignition system control switch to the ON position.
- Replace the ignition system control access panel.
- Reconnect all electric power to the appliance.
- Set the thermostat to the desired setting.
- If the appliance does not turn on, move the ignition system control switch to the OFF position and contact a qualified service technician for assistance.

## Turning off the Appliance

### Vacation Shutdown—

Set the thermostat to the desired room temperature while you are away.

### Complete Shutdown—

Turn off power to the appliance. Turn off the gas supply to the appliance. Appliance will completely shut off. Follow the procedure in the Instructions to the Homeowner section above to resume normal operation.



Resideo Technologies, Inc.  
1985 Douglas Drive North, Golden Valley, MN 55422  
1-800-468-1502

[www.resideo.com](http://www.resideo.com) 69-1059-01 M.S. 03-21 | Printed in United States