



AQ25042B RelayPLUS Zone Synchronizing Boiler Control

System commissioning date: _____

Customer: _____

Building address: _____

INSTALLATION JOB RECORD

INSTRUCTIONS:

Fill in the details of the equipment connected to the control module and the zoning module:

- A.** Low voltage control module wiring
- B.** Low voltage zone thermostats
- C.** Low voltage zone valves with end switches or line voltage pumps
- D.** Line voltage Boiler pump and DHW device
- E.** Review and set DIP switch settings - once the DIP switches for the control module (AQ15000B) and zoning module (AQ15540B) have been set, complete the "Installer Settings" diagrams by filling in the circles to indicate the DIP switch position set during installation.

File this with other installation records for equipment used on this installation.

A Boiler Control Module

Terminal #	9-10	11-12
Terminal ID	DHW	Boiler
Function	DHW demand	Boiler demand
Equipment		
Manufacturer		
Model #		
Serial #		
Date Code		
Notes		

B Zoning Thermostats

Terminal #	5-6	7-8	9-10	11-12
Terminal ID	TH1	TH2	TH3	TH4
Function	Zone call for heat			
Equipment				
Manufacturer				
Model #				
Date Code				
Notes				

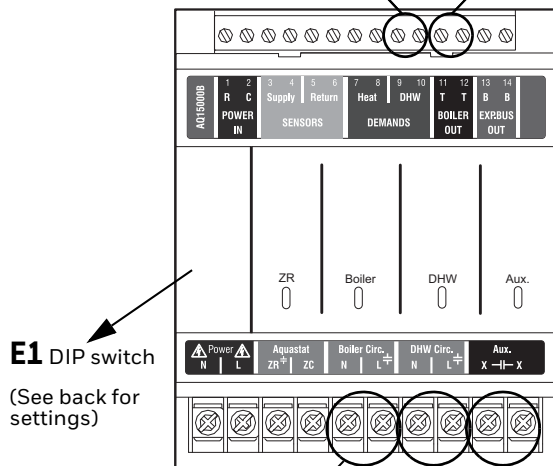

E1 DIP switch
(See back for settings)

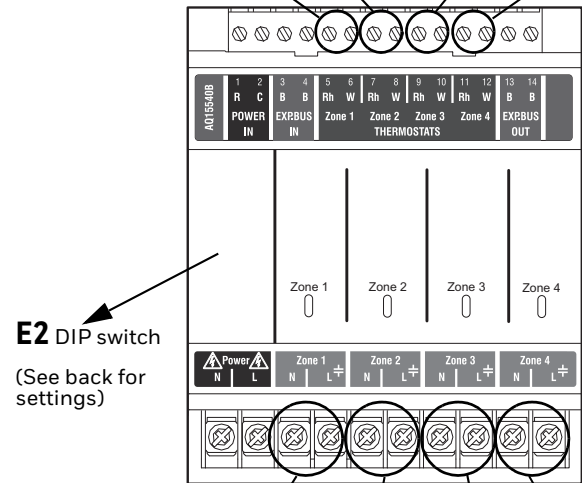

E2 DIP switch
(See back for settings)

D Boiler Pump, DHW, and AUX Device

Terminal ID	Boiler	DHW	AUX
Function	Boiler loop control	DHW loop control	Line voltage-rated Aux device control (installer-defined)
Equipment			
Manufacturer			
Model #			
Power (Amps)			
Notes			

C Zoning Pumps or Valves

Terminal ID	Zone 1	Zone 2	Zone 3	Zone 4
Function	Zone control			
Equipment (circle one)	Pump / Valve	Pump / Valve	Pump / Valve	Pump / Valve
Manufacturer				
Model #				
Power draw Amps (pumps) VA (valves)				
Notes				



E1 Boiler Control Module DIP Switch Settings (AQ15000B)

DIP Switch	Switch Description	Label	Factory Setting	Installer Setting								
DHW	1 DHW Device: Pump or Valve	<table border="1"> <tr><td>Pump</td><td>Valve</td></tr> <tr><td>Off</td><td>Priority</td></tr> <tr><td>Off</td><td>O/Ride</td></tr> <tr><td>Off</td><td>Purge</td></tr> </table>	Pump	Valve	Off	Priority	Off	O/Ride	Off	Purge		
Pump	Valve											
Off	Priority											
Off	O/Ride											
Off	Purge											
	2 DHW Priority: Off or Priority											
	3 DHW Priority Override: Off or O/Ride (override)											
	4 Boiler post purge location: Off = zones only; Purge = DHW tank first, then zones											
Aux.	5 Aux output: Main = default; Group = group pump	<table border="1"> <tr><td>Main</td><td>Group</td></tr> <tr><td>Main</td><td>Bypass</td></tr> </table>	Main	Group	Main	Bypass						
Main	Group											
Main	Bypass											
	6 Aux output: Main = default; Bypass = boiler bypass pump											
Mass	7 Load Mass: Lo = Low mass (baseboard); Hi = High mass (radiant slab)	<table border="1"> <tr><td>Lo</td><td>Hi</td></tr> <tr><td>N/A</td><td>N/A</td></tr> </table>	Lo	Hi	N/A	N/A						
Lo	Hi											
N/A	N/A											
	8 Not used at this time											

Fill in the circle to indicate position of DIP switch.

E2 Zoning Module DIP Switch Settings (AQ15540B)

DIP Switch	Switch Description	Label	Factory Setting	Installer Setting																
1	<p>Zone Address: The positions of these 4 DIP switches define the unique address for each zone on the AQUATROL network. For each group of 4 zones, there can be only one DIP switch in the right hand (On) position.</p> <p>The correct DIP switch settings for each zone module are:</p> <ul style="list-style-type: none"> First Zone (1-4) Module: 1 = ON position; 2, 3, & 4 = OFF position Second Zone (5-8) Module: 2 = ON position; 1, 3, & 4 = OFF position Third Zone (9-12) Module: 3 = ON position; 1, 2, & 4 = OFF position Fourth Zone (13-16) Module: 4 = ON position; 1, 2, & 3 = OFF position 																			
2																				
3																				
4																				
5	<ul style="list-style-type: none"> If set to SYNC, zone synchronization is enabled. If set to NOT, zone synchronization is disabled. 	<table border="1"> <tr><td>Zones</td><td>1-4</td></tr> <tr><td></td><td>5-8</td></tr> <tr><td></td><td>9-12</td></tr> <tr><td></td><td>13-16</td></tr> <tr><td>Sync</td><td>Not</td></tr> <tr><td>N/C</td><td>N/O</td></tr> <tr><td>-</td><td>Group</td></tr> <tr><td>1-Stg</td><td>2-Stg</td></tr> </table>	Zones	1-4		5-8		9-12		13-16	Sync	Not	N/C	N/O	-	Group	1-Stg	2-Stg		
Zones	1-4																			
	5-8																			
	9-12																			
	13-16																			
Sync	Not																			
N/C	N/O																			
-	Group																			
1-Stg	2-Stg																			
6	<ul style="list-style-type: none"> If zone valves are normally closed (N.C.), set the NC/NO DIP switch to the OFF position. If zone valves are normally open (N.O.), set the NC/NO DIP switch to the ON position. 																			
7	<ul style="list-style-type: none"> If set to Group (ON position) the zone outputs are energized with the AUX pump*. If set to - (OFF position), the AUX Pump contacts are not affected by activity on these zones 																			
8	<ul style="list-style-type: none"> If set to 2-Stg (ON position), then 2-stage operation is activated on thermostat inputs. The zoning module operates as two 2-stage zones or 3 zones (one 2-stage and two 1-stage). If set to 1-Stg (OFF position), then operates as four 1-stage zones. 																			

Fill in the circle to indicate position of DIP switch.

* The AQ15000B Boiler Control Module DIP switch #5 must be set to GROUP position and DIP switch #6 must be set to MAIN position.