

AQ251 Series Boiler Reset Control Panels

PRODUCT DATA



PRODUCT DESCRIPTION

The AQ251 Series of AQUATROL® Boiler Reset Controls provides simplified, energy-efficient outdoor temperature compensated control of a high-temperature boiler loop in residential hydronic heating systems. The AQ251 easily converts a single-zone heating system into a room-by-room comfort control system. The boiler controls of the AQ251 can ensure ample supply of hot water for both space heating and priority generation of domestic hot water for bathing, dishes and laundry.

Contents

Specifications	2
1 Installation Preparation	3
2 Mounting	5
3 Wiring Procedure	6
4 Program and Configure the Control Panel	14
5 Test and Check Out the Installation	18
6 Purge Air from all System and Zone Piping	19
7 Document and Keep a record of all System Settings	19
Troubleshooting	20
Appendix	23
User Menu	23
Installer Menu	30

FEATURES

The AQ251 Series has the following features:

- Outdoor temperature compensation (reset), or Load reset based on indoor temperature feedback, or none
- Domestic hot water (DHW) priority and priority override protection.
- Customizable control settings and schedules allow for greater level of control and comfort.
- Central set-back schedules available.
- Zoning Control for up to four, single-stage zones or two, two-stage zones as shipped; can be expanded to a total of 16 zones with AQ255 or AQ257 expansion zoning panels, and up to 64 zones by using up to three AQ254 Add-a-Temperature expansion panels and additional expansion zoning modules.
- Use with digital non-communicating thermostats or AQ1000 2-wire polarity insensitive communicating thermostats.
- When using non-communicating thermostats, the following features are not available:
 - Outdoor temperature is not displayed on the thermostat.
 - Time clock on AQ1000TP2 will not synchronize with the Control Module.
 - Central programming, vacancy and setback schedules of AQ1000 from AQ panel are not enabled.
 - AQ panel will not display individual zone temperatures.
 - Individual zone freeze protection.
- Allows display of outdoor temperature on all AQ1000 thermostats when used with an AQ12C10 outdoor sensor (included).
- Intuitive programming interface (can be programmed at your shop and taken to the job site “ready-to-install”).
- Pump/valve exercise.
- Line or low-voltage output for zoning equipment (pumps or valves).
- Integral 38 VA transformer with self resetting electronic fuse.
- Automated test and purge feature for quick start-up and simplified troubleshooting.
- Two hour power supply module (super capacitor) retains day and time settings during power outage and a non-volatile EPROM memory retains program settings during power outage.



SPECIFICATIONS

The AQ251 Control Panels and corresponding attached equipment are listed in Table 1.

Table 1. AQ251 Series Control Panel Models.

Control Panel	Corresponding Control Module	Corresponding Zoning Module
AQ25110B	AQ15100B	none
AQ25142B	AQ15100B	AQ15540B
AQ25144B	AQ15100B	AQ15740B

Application: Controls one boiler, as well as domestic hot water (DHW) management and zoning operation in a hydronic zoning system.

Power and Electrical Ratings:

Power Supply: 120 Vac / 60Hz

Auxiliary Pump Contact Rating: 120 to 240 Vac, 5A, 1/3 HP

Auxiliary Low Voltage Contact Rating: 24 Vac, 0.5A, 12VA

Boiler (T-T) Contact Rating: 24 Vac, 0.5A, 12VA

Boiler Pump (C1-C2) Output Rating: 120 Vac 5A, 1/3HP

DHW Pump/Valve Output Rating: 120 Vac 5A, 1/3HP

B-B Communication Bus Terminals: Low voltage, Class II, 2-wire polarity-insensitive, digital communicating link to other Control or Zoning modules

Electrical Connections (Line Voltage): Wire-clamp screw terminals; maximum 2 x 14 AWG each on line voltage terminals

Environmental Ratings:

Control and Zoning Panel Temperature Rating: 32°F to 130°F (0°C to 55°C)

Operating Humidity Range (% RH): 5 to 90% RH, non-condensing

Temperature Ratings:

Boiler Design Temperature: 80°F to 210°F (26°C to 99°C)

Boiler Differential: 2°F to 41°F (1°C to 23°C), or Auto

Boiler High Limit Control Temperature: OFF, 120°F to 225°F (OFF, 49°C to 107°C)

Boiler Low Limit Control Temperature: OFF, 60°F to 180°F (OFF, 15°C to 82°C)

Outdoor Low Design Control Temperature: -60°F to 32°F (-51°C to 0°C)

Boiler Minimum Return Control Temperature: OFF, 80°F to 180°F (OFF, 27°C to 82°C)

Sensor Temperature Rating: -58°F to 230°F (-50°C to 110°C)

Warm Weather Shut Down (WWSD) Temperature:

OFF, 35°F to 100°F (OFF, 1°C to 38°C)

Cold Weather Shut Down (CWSD) Temperature: OFF, 32°F to 100°F (OFF, 0°C to 38°C)

Inputs/Outputs:

Auxiliary (Demand) Input: External dry contacts connection only

DHW Demand Input: External dry contacts connection only

R-C Input (on Control and Zoning Modules): 24 Vac Class II

R-C Output (on transformer): 38 VA, 24 Vac Class II

Heat Demand Input External dry contacts connection only

Modulating Output: 0-10 or 2-10 Vdc for variable speed pump or modulating boiler

Mixing Valve Output (floating, open/close) (dry relay): 24 Vac, 12 VA

Interface and Timings:

User Interface (Setting, Programming): LCD Display and a 7-button keypad

Setback Program: 7 day, up to 2 setback periods/day.

DHW Valve Open: 0-230 seconds, before boiler loop pump is energized.

DHW Purge: Yes/No; selects whether purge is applied after a DHW demand is served

Boiler Heat Post Purge: Off, 10 seconds to 30 minutes (factory default is 30 seconds)

Pump/Valve exercise: 30 seconds per 2 weeks of space heating inactivity

Thermostat Compatibility: Digital thermostats and/or AQ1000 Series 2-wire communicating thermostats

Supply/Return Loop Sensor: 10K ohm NTC thermistor at 77°F (25°C) ± 0.5°F (±0.3°C). Lead length: 10 ft. (3.0 m); up to 500 ft. (150 m) using 18 AWG or larger wire, beta=3892.

ORDERING INFORMATION

When purchasing replacement and modernization products from your TRADELINE® wholesaler or distributor, refer to the TRADELINE® Catalog or price sheets for complete ordering number. If you have additional questions, need further information, or would like to comment on our products or services, please write or phone:

1. Your local Honeywell Environmental and Combustion Controls Sales Office (check white pages of your phone directory).
2. Honeywell Customer Care
1885 Douglas Drive North
Minneapolis, Minnesota 55422-4386
3. <http://customer.honeywell.com> or <http://customer.honeywell.ca>

International Sales and Service Offices in all principal cities of the world. Manufacturing in Belgium, Canada, China, Czech Republic, Germany, Hungary, Italy, Mexico, Netherlands, United Kingdom, and United States.

Outdoor Sensor: 10K ohm NTC thermistor at 77°F (25°C) ± 0.5°F (±0.3°C). Lead length: 15 ft. (4.6 m); up to 500 ft. (150 m) using 18 AWG or larger wire, beta=3892

Dimensions (HxWxD): 8 x 16 1/2 x 3 3/8 in. (20.3 x 42 x 8.5 cm) approximate

Weight: 4.9 lb. (2.3 kg)

Approvals: Canadian Standards Association: Certified, File No. LR76030

1 INSTALLATION PREPARATION

NOTES: *Throughout these instructions, the following terminology conventions are used:*

- **AQ251** refers to all of the AQ25142B, AQ25144B and AQ25110B Control Panels. Where there are specific instructions or details relating to the “-42B”, “-44B”, or “-10B” Control Panels, the full model number (i.e. AQ25144B) is used;
- **Control Panel** refers to an assembled product, consisting of a transformer, Control Module and Zoning Module, all contained within an AQ2000 panel enclosure;
- **AQ255** refers to all of the AQ25542B, AQ25542B, AQ25582B and AQ25742B Expansion Zoning Panels, and **AQ257** refers to the AQ25744B Expansion Zoning Panel. Where there are specific instructions or details relating to the “-42B”, “-82B”, “-42B”, or “-44B” Expansion Zoning Panels, the full model number (i.e. AQ25744B) is used;
- **Expansion Zoning Panel** refers to an assembled product, consisting of a Zoning Module and—if applicable—a transformer, contained within an AQ2000 panel enclosure; Expansion Zoning Panels are available in either 4-zone or 8-zone configurations. See Table 1 in “AQ2000 Series Expansion Zoning Panels” (form no. 69-1981) for specific models.
- **AQ151** refers to the AQ15100B Control Module - within an AQ251 Series Control Panel.
- **Control Module** refers to the component within an AQ251 Series Control Panel that performs the “master control operations”. See Table 1 for specific models.
- **Zoning Module** refers to the component within the AQ251 Series Control Panel that controls zoning operations;
- **AQ155** refers to the AQ15540B Zoning Module and **AQ157** refers to the AQ15740B Zoning Module.

When Installing this Product...

1. **Read these instructions carefully. Failure to follow them could damage the product or cause a hazardous condition.**
2. **Check the ratings given in the instructions and on the product to make sure the product is suitable for the application.**
3. **Installers must be trained, experienced, and licensed service technicians.**
4. **Follow local codes for installation and application.**
5. **After installation is complete, check out the product operation as printed in these instructions.**



WARNING

Risk of electrical shock. Can cause severe injury, property damage or death. Disconnect power supply before installation and before servicing.

Check That You Have All the Necessary Equipment For a Successful Installation

- AQ2000 Series components:
 - AQ251 Control Panel
 - AQ Expansion Zoning Panels (if more than four space-heating zones in the system)
 - Digital Thermostats (one for every space-heating zone being controlled)
- Boiler supply and return temperature sensors and secondary loop sensor (included with the AQ251 Control Panel)
- Outdoor temperature sensor (included with AQ251 Control Panel)
- Low voltage thermostat wire
- Zoning equipment (zone valves or pumps)

Read All Instructions Carefully Before Proceeding

The AQ251 Control Panels are a part of a totally new series of hydronic controls. And although they - and other AQ2000 system components - are very easy to install and operate, they are different than other hydronic controls that you have previously installed. So take a moment to read through this quick installation guide before beginning the installation. Failure to follow them could damage the product or cause a hazardous condition.

Familiarize Yourself With the AQ251 Control Panel Layout

Refer to Fig. 1. All AQ251 Control Panels consist of three functional components:

1. AQ10X38 transformer (power supply module), which connects to 120 Vac power and supplies 24 Vac power to the Control Module and Zoning Modules
2. AQ15100B boiler/DHW Control Module, which controls the boiler and domestic hot water (DHW) functions, as well as coordinating the overall operation of the hydronic system.
3. One of two different 4-zone Zoning Modules:
 - AQ15740B (part of the AQ25144B Control Panel) for zoning with 24 Vac zone valves with end switches
 - AQ15540B (part of the AQ25142B Control Panel) for zoning with either line voltage circulators or 24 Vac zone valves without end switches.

AQ251 Control Panels can control a maximum of 16 zones by connecting additional Expansion Zoning Panels to the AQ251 Control Panel. Each Expansion Zoning Panel is configured with its own bank of DIP switches, located in the left-most section of each Zoning Module.

AQ251 SERIES BOILER RESET CONTROL PANELS

In general, the top terminals of the AQ2000 Series components carry low voltage (24 Vac) power and the bottom terminals carry line voltage (120 Vac) power. This is illustrated in Fig. 1. The only exception to this is the AQ15540B Zoning Module when used with low voltage zone valves (without end switches). In this case, the bottom terminals of the Transformer and Control Module carry line voltage (120 Vac), but the bottom terminals of the Zoning Module will carry low voltage (24 Vac) power.

The powered terminals on the bottom of the AQ2000 Series Control Modules and Zoning Modules are connected internally, as shown in Fig. 2. The voltage supplied to the N and L terminals is also available at the adjacent terminal pairs when the hot (⊕) relays are switched.

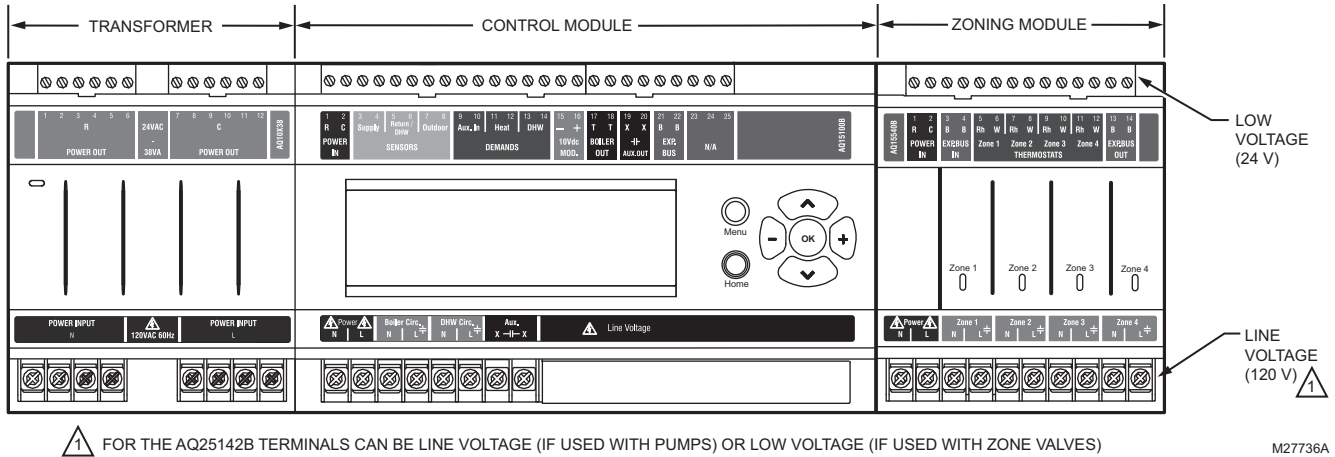

⚠ FOR THE AQ25142B TERMINALS CAN BE LINE VOLTAGE (IF USED WITH PUMPS) OR LOW VOLTAGE (IF USED WITH ZONE VALVES)

M27736A

Fig. 1. AQ251 Control Panel layout (AQ25142B shown).

⊕
CONTACTS
SYMBOL

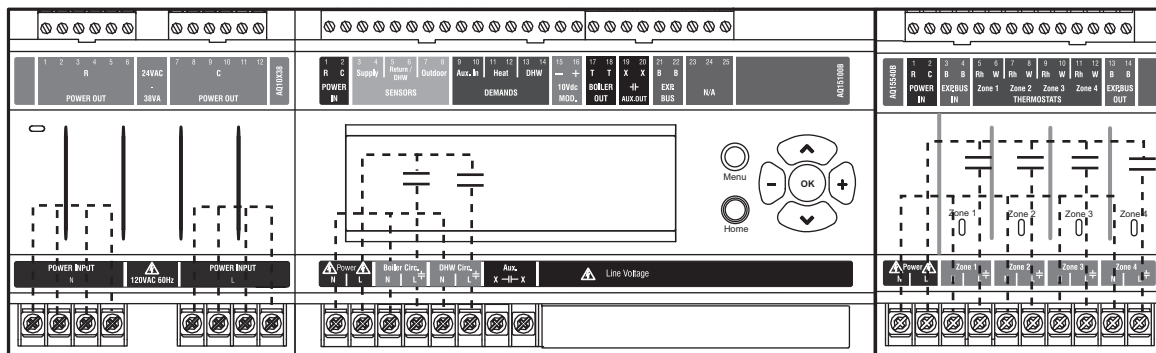

M27737A

Fig. 2. Internal wiring for AQ2000 Series components line voltage relays.

2 MOUNTING

This section describes how to mount the Control Panel, Expansion Zoning Panels, and the Thermostats.

Mount AQ251 Control Panel

Mount the control panel on the wall:

1. Use the template supplied with the AQ251 Series Control Panel to mark mounting holes for panels
2. Install two top screws, mount the panel, and install the two lower screws.

Mount Expansion Zoning Panel(s)

If there are Expansion Zoning Panels to install, mount them to the wall now:

1. Remove wire channel plugs from the AQ251 Control Panel and any Expansion Zoning Panels (see Fig. 3).
2. Mount Expansion Zoning Panel on the right-hand end of the AQ251 Control Panel. Install two top screws of the Expansion Zoning Panel, ensuring it is level with the adjoining Control Panel, and install two lower screws.
3. Reverse wire channel plugs and re-insert them into their slot, to form a wiring channel between the Control Panel and the Expansion Zoning Panel (see Fig. 3) and to connect the two panels together.
4. Repeat steps 1–3 for any additional Expansion Zoning Panels.

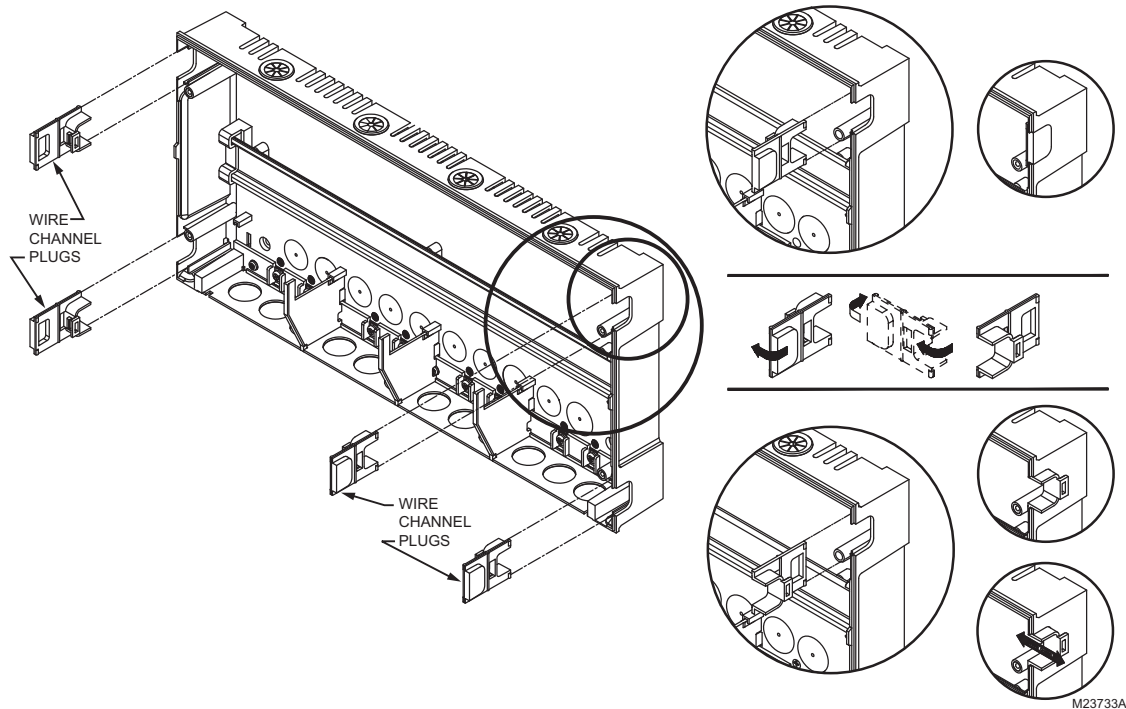

Fig. 3. Orientation of wire channel plugs for creating pass-through wire channel and for joining Control Panel to Expansion Zoning Panels.

Mount and Wire Thermostats in the Zones

Install the thermostats on the walls in the zones that are to be controlled by the AQ251 Control Panel.

When using AQ1000 thermostats refer to the installation instructions (form #69-2005) included with the AQ1000 thermostats.

If not done already, run low voltage thermostat wire (24 gauge or heavier) from the thermostats back to the Zoning Modules connected to the AQ251 Control Panel.

NOTES: If not otherwise specified, low voltage wiring should be run with 18 gauge thermostat wire and line voltage wiring should be run with 14 gauge wire. AQUATROL® line voltage screw terminals are only approved for use with 22 to 12 gauge copper conductors.

Several wiring diagrams are included in this document. For additional information, refer to <http://customer.honeywell.com> or your local distributor.

3 WIRING PROCEDURE

The AQ251 Control Panel is pre-wired at the factory, making for faster installation:

- For all models, the low voltage output terminals located at the top of the transformer are wired to the R and C input terminals of the Control Module.
- For those Control Panel models that come with Zoning Modules included, (all but the AQ25110B), the transformer's low voltage outputs are also wired to the R and C inputs of the Zoning Module. The B-B "Exp. Bus" terminals of the Control Module are wired to the B-B "Exp. Bus IN" terminals of the Zoning Module.

Beginning with the top left of Fig. 4 and moving clockwise around the panel, wire components to the AQ251 Control Panel and Expansion Zoning Panels (if installed) in the following six steps:

- "Step 1 – Transformer Wiring"
- "Step 2 – Control Panel Wiring"
- "Step 3 – Thermostats Wiring" on page 9
- "Step 4 – Zoning Equipment Wiring" on page 9
- "Step 5 – Line Voltage System Outputs" on page 12
- "Step 6 – Connection to Line Voltage Power" on page 13

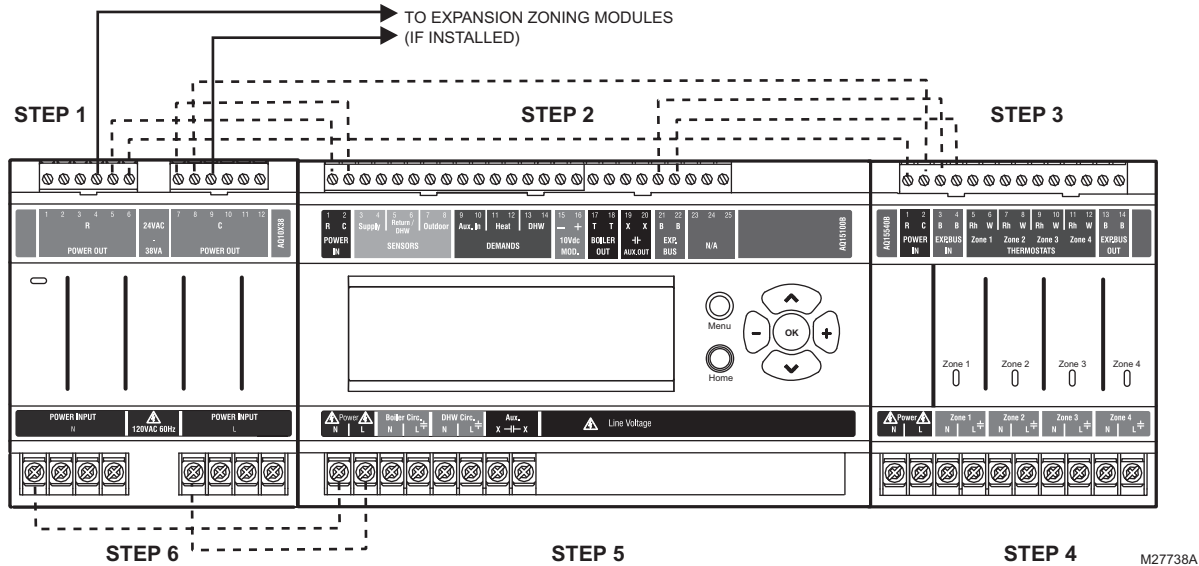

Fig. 4. Wiring sequence.

Step 1 – Transformer Wiring

Factory pre-wiring of the Control Panels is shown as dotted lines in Fig. 4.

In addition to the pre-wiring, run low voltage jumper wires from available R and C terminals on the secondary of the transformer to the R and C terminals of any Expansion Zoning Panel.

Step 2 – Control Panel Wiring

Wire the Temperature Sensors, System Demands, Low Voltage Outputs, and Communication Bus (Refer to Fig. 5 for wiring terminals on the top of the AQ251):

- "Temperature Sensor Wiring" on page 7
- "System Demands Wiring" on page 7
- "Low Voltage Outputs Wiring" on page 8
- "Communication Bus Wiring" on page 8

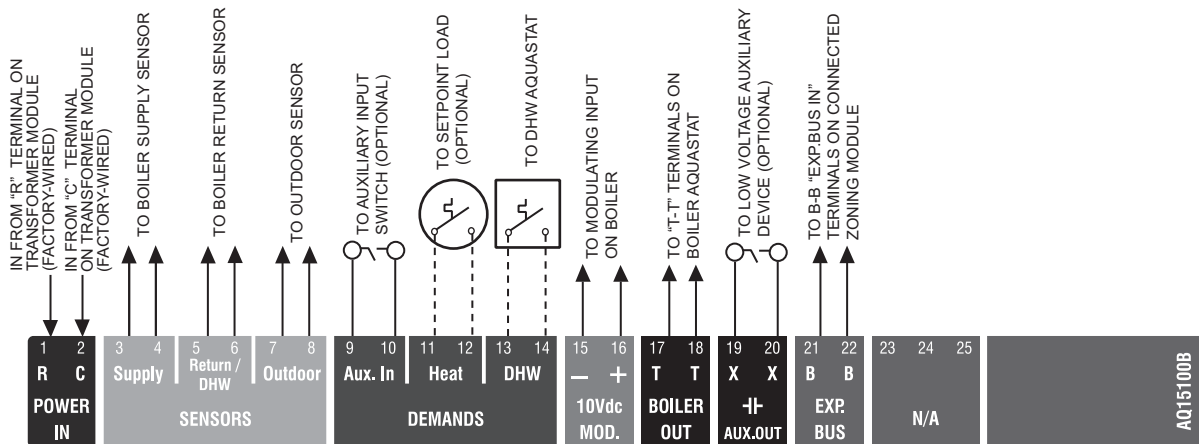

Fig. 5. Low voltage wiring for the AQ15100B Control Module.

Temperature Sensor Wiring

Connect the lead wires of each sensor to the corresponding terminals on top of the AQ151 Control Module. See Fig. 5 on page 6.

The Boiler Supply, Return and Secondary loop sensors can be installed either as strap-on sensors or inserted into an immersion well that is packed with thermally-conductive paste.

BOILER SUPPLY AND RETURN SENSORS.

Both the Supply and Return Sensors should be installed on the supply and return piping of the boiler for proper operation of the AQ251 Control Panel. Even if the AQ251 is connected to a modulating condensing boiler with its own supply and/or return sensors, the AQ251's sensors should still be installed for the control to operate.

The Boiler Supply water sensor should be installed on the supply piping close to the exit port of the boiler, using one of the AQ12C11 strap-on sensors supplied with the AQ251. See Fig. 6.

The Boiler Return sensor should be installed on the return piping as close to the entrance port to the boiler as practical, using the other AQ12C11 strap-on sensor supplied with the AQ251.

The correct location is one that will measure the temperature of all combined sources of water returning back to the boiler.

Insulate strap-on sensors with pipe wrap to ensure accurate boiler temperature sensing.

The Boiler Supply and Return water sensors come with 10 ft. (3m) of wire to minimize the need for splicing.

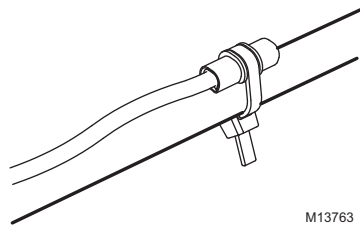

Fig. 6. Strap-on temperature sensor installation.

OUTDOOR SENSOR

The outdoor sensor should be located:

- in a shady location out of direct sunlight
- at least three feet from dryer, bathroom, or other vents
- above the expected snow line where ice and debris cannot cover it
- on the north side of the building.

See Fig. 7 for typical placement. Outdoor sensor comes with 10 ft. (3m) of wire to facilitate splicing the sensor on the interior of the building. Alternatively, if the building is equipped with a continuous fresh air supply using, for example, an air-to-air heat exchanger, the outdoor sensor may be installed in the insulated portion of the ventilation intake duct, taking care not to expose the sensor to direct or indirect sunlight.



Fig. 7. Outdoor temperature sensor installation.

IMPORTANT

Do not run sensor wires parallel, or close, to telephone, Ethernet, or power cables. Cross all power, Ethernet, and telephone wiring at right angles. If sensor wires are located in an area with strong sources of electromagnetic interference, or EMI, (e.g., if sensor wires are run in the same electrical chase as line voltage wiring) use twisted pair, shielded cable, or run wires in a grounded metal conduit. This is important, since the calculated temperature - based on the sensor's resistance reading - can be distorted by high EMI, potentially causing the AQ251 to not operate properly. If using shielded cable or conduit, connect the shield wire to earth ground only at the AQ251 panel. Do not ground the shield or conduit at any other location or electromagnetic shielding will be ineffective. If shielded cable is used, Honeywell recommends the use of shielded cable with a continuous ground plane, such as foil, with an integral drain wire for bonding to earth ground.

System Demands Wiring

Additional information about settings for the various System Demands is discussed in Table 6 on page 30.

AUX-IN

If the optional Aux In. contacts (terminals 9 and 10) will be used, wire them now. These inputs are powered with 24 Vdc and must connect only to a dry closure contact (unpowered switch).

The Aux-In contact closure sets the system into a specific state, as determined by the installer setup using the EQUIPMENT SETUP > AUXILIARY I/O sub-menu (see Fig. 25 on page 39).

HEAT DEMAND

If the optional Heat Demand (terminals 11 and 12) will be used, wire them to a system setpoint demand (dry contact closure), such as a pool or spa Aquastat®.

The HEAT contact closure drives the system to control either at the Reset temperature or the Setpoint temperature, as determined by the installer setup using the EQUIPMENT SETUP > ZONING > HEAT DMND selection (see Fig. 25 on page 39). Heat Demand priority allows only heat for the first 30

minutes of a call for heat and then allows the space heating needs to be added in for the next 30 minutes. This cycle continues until the call for heat is satisfied.

DOMESTIC HOT WATER

Wire the DHW (terminals 13 and 14) to the Aquastat or thermostat on the domestic hot water tank.

DHW priority allows only DHW heat for the first 30 minutes of a call for DHW and then allows the space heating needs to be added in for the next 30 minutes. This cycle continues until the call for DHW is satisfied.

NOTE: If the AQ251 is connected to a modulating condensing boiler with built-in DHW management, the DHW tank's Aquastat should be connected to the AQ251's DHW (terminals 13 and 14). The AQ251's Aux. Out (terminals 19 and 20) should be wired to the boiler's DHW input terminals to the AQ251. In this case, the Aux Out contacts should be programmed (in Installer Mode settings) to close when there's a call for DHW [EQUIPMENT SETUP>AUXILIARY IO>AUX.OUT>DHW]

Low Voltage Outputs Wiring

10 Vdc

The 10 Vdc terminals (15 and 16) of the AQ251 produce a modulating (0-10 Vdc or 2-10 Vdc) signal that can drive a modulating boiler's combustion fan to maintain a constant supply temperature from the boiler (generally equal to the Boiler High Limit setting in the EQUIPMENT SETUP > BOILER SETTINGS sub-menu).

Boiler Signal: If the AQ251 panel is configured to send a 0-10V or 2-10V signal to a modulating/condensing boiler, connect the AQ251's modulating output terminals (15 and 16) to the modulating signal input on the boiler control.

BOILER

Wire the Boiler dry contact output (terminals 17 and 18) to the T-T terminals on the boiler Aquastat or the boiler's control panel. See Fig. 15 on page 12 for wiring connections to a typical boiler Aquastat.

These contacts are made any time the system has a request for boiler operation, unless the water supply temperature is above the target temp at that time, at which time the system primary boiler pump would come on.

AUX-OUT

If the Auxiliary Out low voltage output will be used, wire it now to the device that will be switched when the Auxiliary Out's dry contacts close. Wire the hot leg of the device through the Aux. Out connection (terminals 19 and 20).

The Aux-Out relay contacts close to correspond with an action as determined by the installer setup using the EQUIPMENT SETUP > AUXILIARY I/O sub-menu (see Fig. 25 on page 39).

NOTE: The Aux. Out contacts are rated for low voltage devices only.

Communication Bus Wiring

All AQ2000 components communicate with each other on the AQUATROL network using communication bus wiring. This wiring must connect all AQ2000 components. Otherwise, features that depend on this networked communication (e.g., zone synchronization, outdoor temperature displayed on thermostats, etc.) will not function.

The communication bus wiring is polarity insensitive. The installer does not need to worry about a +ve or -ve orientation of the wires. If there are two wires connected between the B-B Bus Exp. In on one module and B-B Bus Exp. Out on another module, there will be communication. See example in Fig. 8 for how this wiring is to be installed.

The communication bus connections for AQ251 Control Panels are pre-wired at the factory. If connecting an Expansion Zoning Panel to an AQ25110B, wire the Control Panel's B-B "Exp.Bus" terminals (21-22) to the B-B "Exp. Bus IN" terminals (3-4) of the Expansion Zoning Panel.

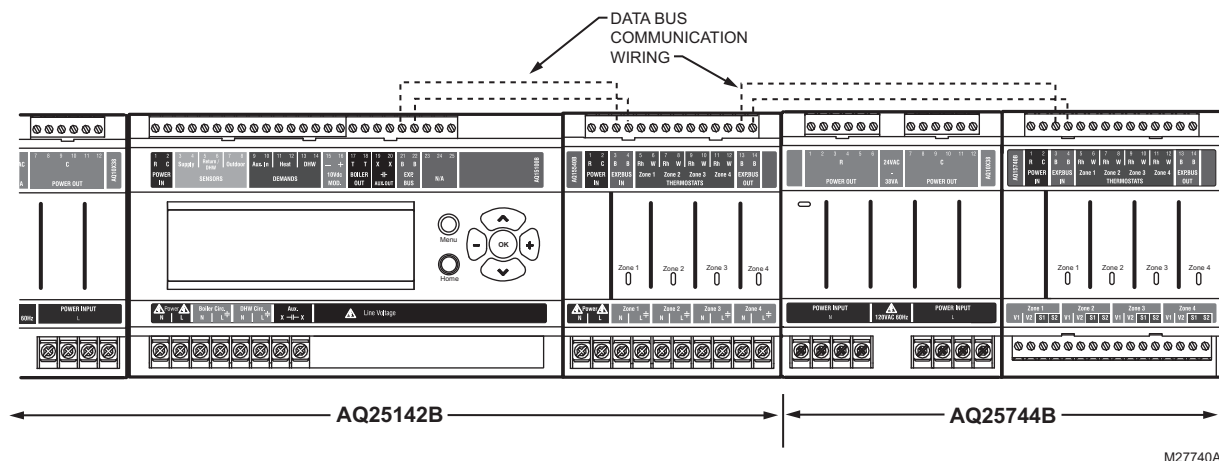

Fig. 8. Wiring for communication bus.

Step 3 – Thermostats Wiring

NOTE: The new AQ2000 panels will work with either digital (electronic) non-communicating thermostats or AQ1000 communicating thermostats.

- Using low voltage thermostat wire, connect one thermostat from each zone to the corresponding THERMOSTATS Zone X inputs on top of the Zoning Module (see Fig. 9).
- If there are additional zones (on Expansion Zoning Panels) connected to this Zoning Module, run low voltage thermostat wiring from the B-B Exp. Bus Out connection (terminals 13 and 14) of the Zoning Module to the B-B Exp. Bus. In connection (terminals 3 and 4) on the Expansion Zoning Panel.

IMPORTANT

Do not run thermostat wires parallel, or close, to telephone, Ethernet, or power cables. Cross all power, Ethernet, and telephone wiring at right angles.

If thermostat wires are located in an area with strong sources of electromagnetic interference, or EMI, (e.g., if thermostat wires are run in the same electrical chase as line voltage wiring) use twisted pair, shielded cable, or run wires in a grounded metal conduit.

This is important, because the AQ1000 thermostats are communicating thermostats which send and received data via the two wires connecting them to the Zoning Module. This data can be distorted by the EMI, potentially causing the AQ251 to not operate properly.

- Run low voltage thermostat wiring from the R and C terminals on the AQ251 Control Panel's transformer to the R and C terminals on the Expansion Zoning Panel. As an alternative, you can run low voltage thermostat wiring from the R and C terminals on the Zoning Module to the R and C terminals on the Expansion Zoning Panel.

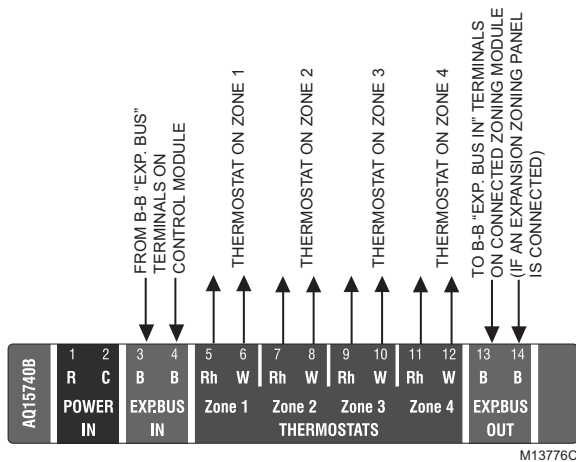

Fig. 9. Connecting AQ1000 thermostats.

Step 4 – Zoning Equipment Wiring

Because the Zoning Module of the AQ25142B Control Panel can be used with either low voltage zone valves (without end switches) or line voltage pumps or valves, field installed wiring of the correct voltage needs to be connected to the zoning equipment terminals on the bottom left portion of the Zoning Module.

Line Voltage – Circulators or Zone Valves

Refer to Fig. 10. Remove the plastic wiring barrier that is located in the bottom wiring channel between the AQ15100B Control Module and the Zoning Module. Run jumper wires from the N and L terminals on the bottom of the AQ251 Control Panel's transformer, through the wiring channel across the bottom of the Control Panel, and to the corresponding N and L terminals of the Zoning Module.

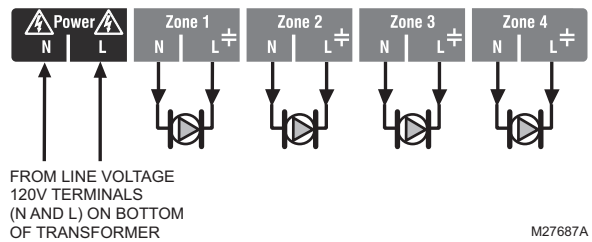

Fig. 10. Wiring an AQ15540B Zoning Module for use with line voltage circulators.

Low Voltage – Zone Valves With or Without End Switches

Wire using step 1 for zone valves without end switches, or use step 2 for zone valves with end switches:

- Low voltage zone valves without end switches: Using Fig. 12 on page 10 as a guide, run jumper wires from the R and C terminals on the secondary of the AQ251's transformer, through the wiring channel across the top of the Control Panel, and down through the wiring channel on the right side of the panel and over to the R and C terminals on the bottom of the Zoning Module.

IMPORTANT

*If low voltage zone valves are used with the AQ25142B Control Panel, the supplied Low Voltage Output sticker (shown in Fig. 11) **must** be applied over the line voltage output sticker (see Fig. 10) that is already attached to the Zoning Module.*

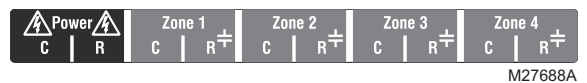

Fig. 11. Low voltage output sticker.

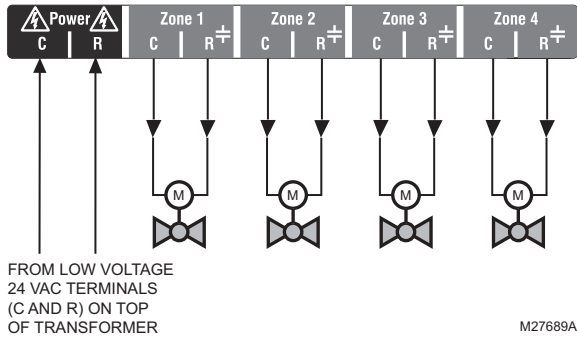

Fig. 12. Wiring an AQ15540B Zoning Module for use with low voltage zone valves without end switches.

2. Low voltage zone valves with end switches:
See Fig. 13. 24 Vac power is pre-wired between the transformer secondary at the top left of the AQ251's transformer and the AQ15740B Zoning Module. No field wiring is required.

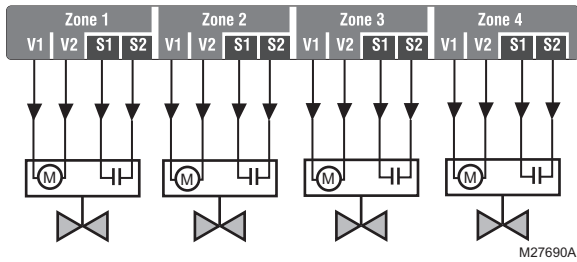

Fig. 13. Wiring an AQ15740B Zoning Module for use with low voltage zone valves with end switches.

NOTE: When wiring zone valves with end switches, note the transformer's VA:

If low voltage zone valves with end switches are used for zone control, make sure the selected zone valves do not draw more power (VA) than the 38 VA capacity of the AQ10X38 transformer supplied with the AQ251 Control Panel. This integral transformer has enough power to operate 4 motorized zone valves (such as Honeywell V8043E valves or 4 valves using low-amperage draw, heat motor actuators, such as Honeywell MV100 actuators), plus power the electronics of the AQ251's Control Module and up to 16, AQ1000 thermostats. If zone valves with high-amperage-draw heat-motor actuators are used (such as Taco 500 series zone valves), additional 24 Vac transformer capacity will need to be wired to the Zoning Module to power the valves. See Fig. 14 on page 11 for recommended wiring of additional low voltage VA capacity to AQ2000 Series Zoning Modules.



CAUTION

Equipment Damage Hazard.

Can damage internal circuitry of Zoning Module.

The ES1 and ES2 terminals of the AQ15740B Zoning Module are powered terminals and must only be connected to a set of dry contacts, such as a zone valve motor's end switch. If power is applied to these contacts (for example, by running line voltage through the zone valves' end switches to bring on a circulator feeding those valves), the internal circuitry of the Zoning Module will be damaged, in which case the warranty for this product will be voided.

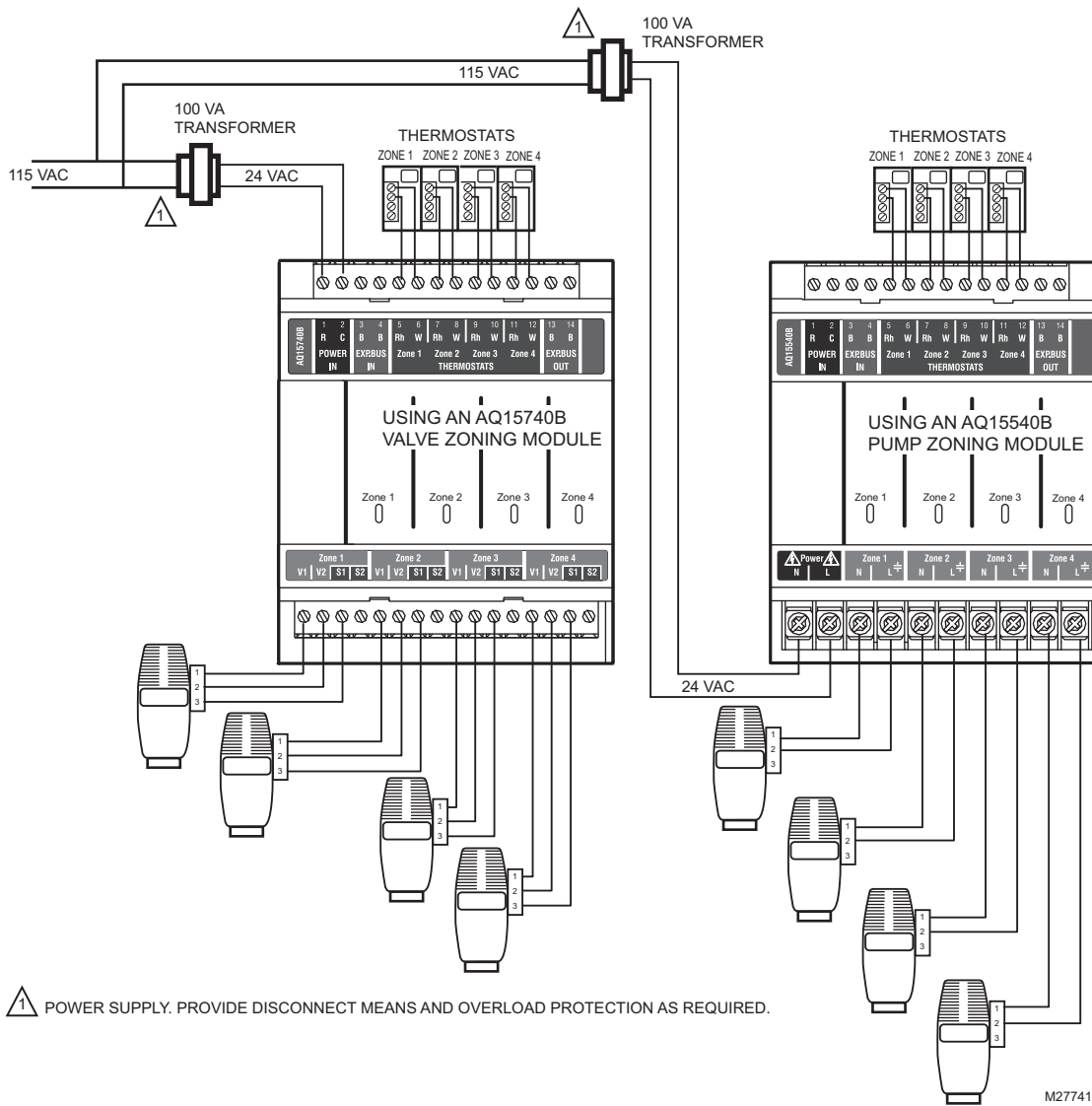

Fig. 14. Wiring of additional low voltage VA capacity.

Step 5 – Line Voltage System Outputs

Refer to Fig. 15 and follow the steps in this section to wire these devices to the AQ251 Control Module.

- “1. Boiler Pump”
- “2. DHW Device”
- “3. Line Voltage Rated Aux Output (Aux. pump)” on page 13

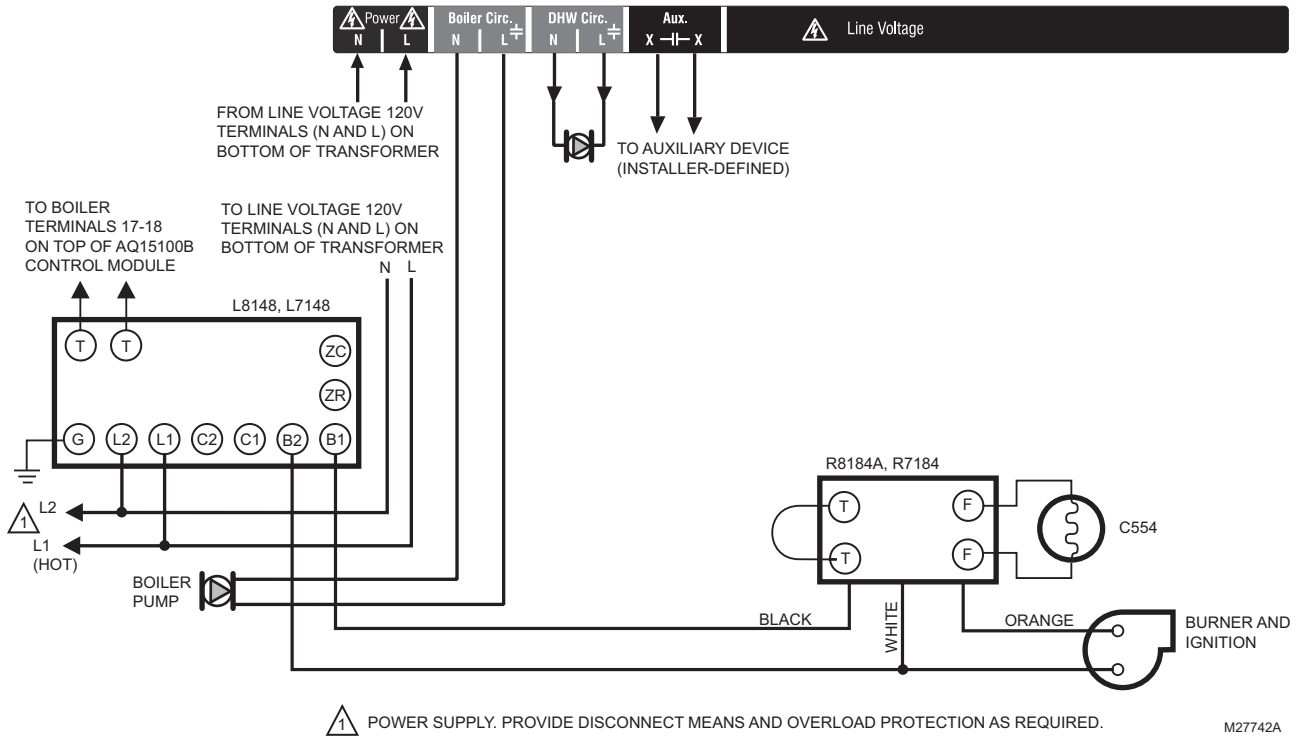

Fig. 15. Line Voltage Connections for AQ251.

1. Boiler Pump

Connect the N and L wires of the boiler loop pump to the N and switched hot terminals of the line voltage Boiler output, shown in Fig. 17 on page 13. The ground wire of the pump can be connected to any of the 8 ground screw terminals located on the back surface of the Control Panel enclosure.

The boiler pump contacts are made after any one of the following occur:

- A call for heat has occurred from any heating zone.
- The Heat input is shorted on terminals 11 and 12.
- The DHW input is shorted and the DHW type is configured as a valve.

The pump is delayed for the FIRE DELAY programmed in the EQUIPMENT SETUP > BOILER OPERATION sub-menu (see Fig. 25 on page 39). The boiler pump and the last zone calling remain on in order to move heat out of the boiler for the period of time programmed in the Purge time menu under the fire delay. Manually adjusting thermostats affects the operation of this software so it can not be tested manually, you must observe it under normal operating conditions.

NOTE: If the AQ251 is connected to a modulating condensing boiler, the boiler pump may need to be connected to the boiler, not the AQ251. Confirm this with the boiler’s installation manual.

2. DHW Device

Wire the DHW pump or line voltage zone valve to the N and switched hot terminals of the DHW output, as shown in Fig. 17 on page 13.

If using a low voltage zone valve, wire the primary of a spud-mounted transformer (115V to 24V) to the DHW line voltage output contacts and connect the low voltage zone valve to the secondary terminals of this transformer. A spud-mounted transformer may be located in one of the conduit knockouts on the bottom of the AQ251 Control Panel.

Alternatively, a 24 Vac zone valve can be connected to the Aux. pump line voltage-rated dry contacts, which can be configured to close on a DHW call. This configuration is defined in the Installer Equipment Setup menu beginning on page 30.

The DHW contacts are made when the DHW inputs on terminals 13 and 14 are shorted by the controlling Aquastat. This is a line voltage output designed to go to the DHW pump. If 24 Vac is needed for a low voltage valve, you can mount a step-down transformer on the conduit opening and wire the valve from the transformer. When DHW is enabled, the system has a 30-minute priority over all calls for heat. After 30 minutes, calls for heat are added back in to the operation for 30 minutes and then turned off again. This repeats until the DHW is satisfied.

3. Line Voltage Rated Aux Output (Aux. pump)

To connect a line voltage auxiliary device to these contacts, such as a boiler bypass pump, power the pump from the N and L terminals on the bottom of the Control Module, running the L (hot) lead through the AUX.Pump contacts. See Fig. 16 for details. The exact wiring schematic will depend on what is connected to these dry contacts.

The Aux Pump is a line voltage-rated dry contact that is controlled by the selection in the EQUIPMENT SETUP > AUXILIARY I/O sub-menu (see Fig. 25 on page 39).

NOTE: Use of this output is optional. The Aux. pump dry contacts are line voltage-rated but unpowered. A low voltage device can be connected to these programmable contacts, but the wire's insulation must meet applicable codes for use in line voltage enclosures. See page 30 for programming options for the Aux. Pump dry contacts.



Fig. 16. Wiring of the Aux. pump line voltage rated dry contacts (example shown is a by-pass pump).

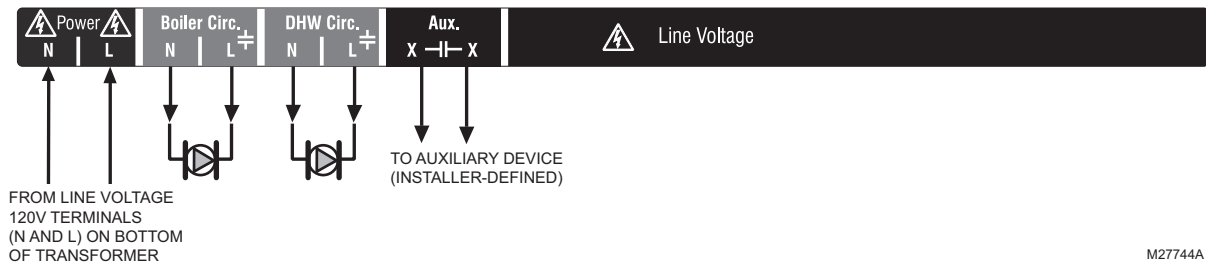

Fig. 17. Wiring for Boiler Pump, DHW Device, and Aux Output.

Step 6 – Connection to Line Voltage Power

Connect the N and L line voltage inputs of the AQ251 Control Panel (at the bottom of the transformer) to the electrical distribution panel and power up the Control. A service switch should be installed on the hot (L) lead to the distribution panel.

If multiple Zoning Modules are connected to the AQ251 Control Panel, the line voltage wiring can either be run directly from the N and L terminals on the primary of the transformer to each Zoning Module (Fig. 18), or run in a daisy chain from the N and L terminals of one AQ2000 module to the N and L terminals of the next AQ2000 module (Fig. 19 on page 14).

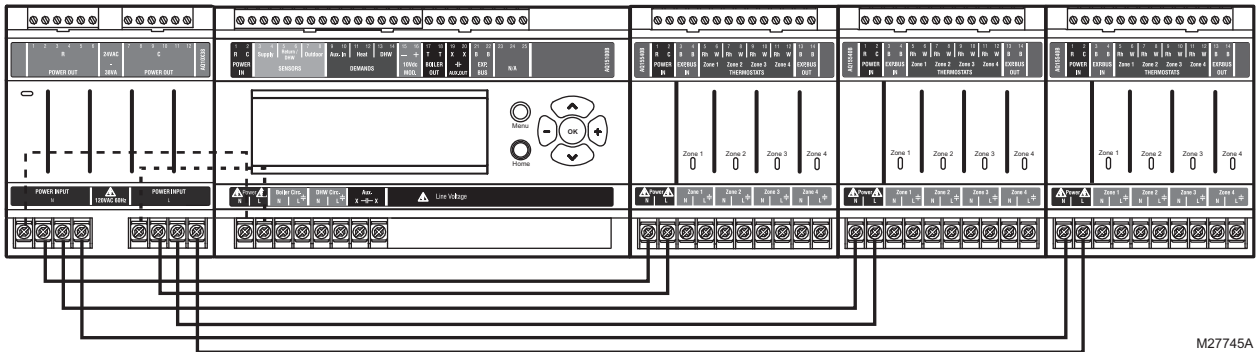
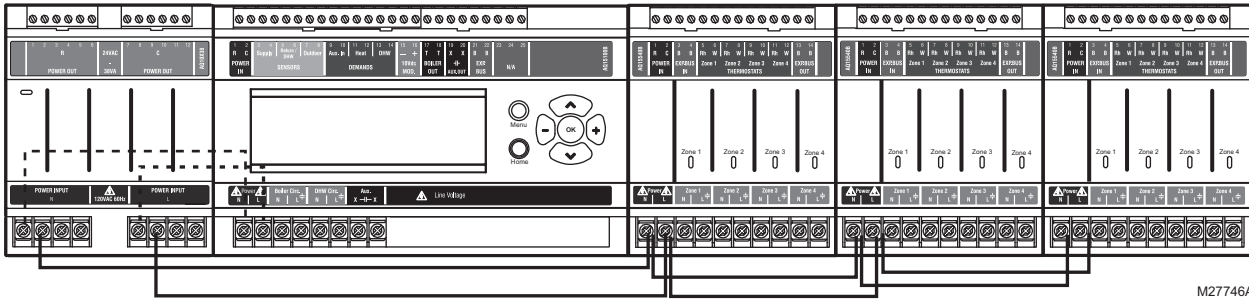

Fig. 18. Connections for multiple Zoning Panels - parallel wiring.



M27746A

Fig. 19. Alternate Connections for multiple Zoning Panels - daisy chain wiring.

CAUTION

Electrical Shock or Equipment Damage Hazard. Can shock individuals or short equipment circuitry. When line voltage is applied to the AQ251 Control Panel and the front cover of the Panel is removed, there is a risk of electrocution. Be careful to avoid contact with the line voltage (N and L) terminals, either with your fingers or with metal tools (such as a screwdriver) when power is applied to the Control Panel.

Although these factory default values for the Control Module and each Zoning Module are suitable for many installations, Honeywell recommends that they be reviewed, and changed as necessary, to get optimal performance of the hydronic system controlled by the AQ2000 Series products.

Zoning Module DIP Switch Location

The AQ15540B (pump Zoning Module) and AQ15740B (valves with end switches Zoning Module) both have DIP switches in 8-switch banks and are concealed behind snap-on covers, as shown in Fig. 20.

4 PROGRAM AND CONFIGURE THE CONTROL PANEL

Only two steps are required to set up the AQ251 Series Control Panel:

1. Check the program settings for the Control Module: Operation of the AQ251's Control Module is set by the menu selections accessible through the Control Module's LCD screen. See "AQ251 – System Programming" on page 16 for instructions.
2. Check the DIP switch settings for each Zoning Module.

Control Panel Defaults

Operation of the AQ251 Control Module is set by the menu selections accessible through the Control Module's LCD screen. See "AQ251 – System Programming" on page 16 for instructions.

The AQ251 Control Panels are shipped from the factory with pre-defined values for all program settings. These factory default settings are commonly used by hydronics contractors across North America. Usually, most of the settings only need to be checked by the installing contractor to make sure they are suitable for the job, rather than having to input all the settings from scratch.

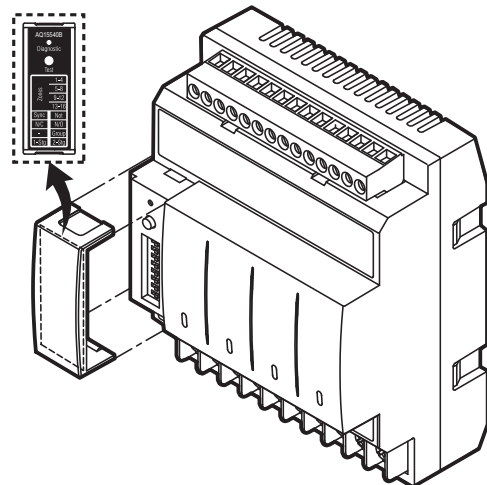

M23731A

Fig. 20. Location of the DIP switches for the AQ155/AQ157 Zoning Modules.

Zoning Module DIP Switch Settings

A chart of the different settings for each DIP switch is attached to the inside of each DIP switch cover.

Refer to Table 2 on page 15, and check all DIP switch settings. If necessary, change the switch settings to suit the desired operation of the hydronic installation.

NOTES:

1. To set DIP switches 1 through 4, which identify the unique address of each zone on the AQUATROL network:
 - Refer to the descriptions in Table 2 for the correct DIP switch settings for the Zoning Module. Unpredictable zone behavior may occur if more than one Zoning Module has DIP switches (1-4) set to the same address.
2. DIP Switch 5 enables or disables Zone Synchronization:
 - The factory setting disables Zone Synchronization, which is an energy saving feature of the AQ2000 panels. Zone Synchronization coordinates zone demands to start at the same time when the boiler cycle begins. The AQ2000 functions as activating valves. The valve logic induces a delay before activating the boiler pump even when zone pumps are used. When Zone Synchronization is not selected, the zone demands are served whenever they call for heat.
 - The Zone Synchronization feature replaces the pump/valve selection of previous AQ2000 versions.

3. DIP Switch 8 functionality:
 - The factory setting enables 1-stage per zone thermostat. The zoning module operates as four 1-stage zones.
 - When using a 2-stage thermostat, set DIP switch 8 to 2-Stg. The 2-stage selection uses TH1 and TH2 inputs for 2-stage thermostat control. For the selected zone, TH1 is the first stage input from the thermostat and TH2 is the second stage input. Inputs TH3 and TH4 operate in same manner. The 2-stage selection reduces the zoning module to a 2 zone module from a 4 zone module.
 - When using digital 2-stage thermostats (non AQ1000 thermostats), the system set-up process changes slightly. During system set-up, create an artificial demand on the zoning module by increasing the set point on the thermostat. The artificial demand is required during the PRI/SEC set-up menu to select the primary and secondary loop for each zone and stage.

Review the settings of all DIP switches for each Zoning Module connected to an AQ1510 Control Module, to ensure they are correct before system start-up.

When you finish setting the DIP switches for all the Zoning Modules, replace the front cover of the AQ251 Control Panel and the cover of each Expansion Zoning Panel.

NOTE: The snap-on DIP switch covers are designed so they cannot be removed (exposing the DIP switches) when the front cover of the AQ251 Control Panel is in place.

Table 2. AQ15540B Zoning Module (Pump Zoning Module) DIP Switch Arrangement.

DIP Switch	Switch Description	Label and Factory Settings
1 2 3 4	<p>Zone Address: The positions of these 4 DIP switches define the unique address for each zone on the AQUATROL network. For each group of 4 zones, there can be only one DIP switch in the right-hand (ON) position.</p> <p>The correct DIP switch settings for each zone module are:</p> <ul style="list-style-type: none"> • First Zone (1-4) Module: 1 = ON position; 2, 3, and 4 = OFF position • Second Zone (5-8) Module: 2 = ON position; 1, 3, and 4 = OFF position • Third Zone (9-12) Module: 3 = ON position; 1, 2, and 4 = OFF position • Fourth Zone (13-16) Module: 4 = ON position; 1, 2, and 3 = OFF position 	
5	<ul style="list-style-type: none"> • If set to SYNC, zone synchronization is enabled. • If set to NOT, zone synchronization is disabled. 	
6	<ul style="list-style-type: none"> • If zone valves are normally closed (N.C.), set the NC/NO DIP switch to the OFF position. • If zone valves are normally open (N.O.), set the NC/NO DIP switch to the ON position. 	
7	<ul style="list-style-type: none"> • If set to Group (ON position), the AUX Pump contacts on the Control Module are switched when any of the zones on this Zoning Module are active. • If set to - (OFF position), the AUX Pump contacts are not affected by activity on these zones. 	
8	<ul style="list-style-type: none"> • If set to 2-Stg (ON position), then 2-stage operation is activated on thermostat inputs. The zoning module operates as two 2-stage zones or 3 zones (one 2-stage and two 1-stage). • If set to 1-Stg (OFF position), then operates as four 1-stage zones. 	

AQ251 – System Programming

This section describes how to navigate the user interface using the keypad and LCD display, and how to program the AQ251 Control Panel, which begins on page 17.

Keypad

The AQ251 User Interface consists of an LCD screen (16 characters by 3 rows) and a 7-button keypad for navigating the menus, as illustrated in Fig. 22. Fig. 21 provides an isolated view of the keypad.

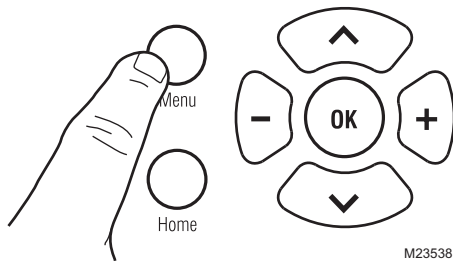

Fig. 21. AQ251 keypad.

- Menu** Press this button to access the User Menu. When pressed while in a sub-menu, the sub-menu's values are saved before going up one level in the current menu.
- Home** Press this button to leave the User or Installer Menu and return to the Home Page display screen.
- OK** Press this button to enter a sub-menu of the active menu item. A menu item is active when the indicator arrow (←) is positioned beside the item.

- ^ and v Press these buttons to scroll up/down in the menu items. Pressing one of these buttons automatically saves your current selection, exits the edit mode, and moves to the previous or next menu item.
- and + Press these buttons to decrease/increase the value of a selected menu item, or to scroll through a list of pre-defined options.
 - If the menu item being modified is a number, the displayed value will decrease/increase by pressing these buttons. When holding the - or + button for more than a second, the values automatically decrease/increase at a faster pace, similar to setting the time on a digital clock radio.
 - If the menu item is an option, pressing these buttons scrolls through the list of available options one at a time.

LCD Display

The LCD on the AQ251 Control Panel is used to:

- Monitor system status and performance.
- Select and/or modify control settings for the hydronic system.
- Diagnose and troubleshoot system problems.

The layout of the display is logical and simple to navigate. The information displays so that the installer can see at a glance the system's operating temperatures, as well as the status of the system equipment, such as a call for heat, DHW pump on, Boiler T-T terminals energized, etc. In addition, all system information displays in simple, straightforward English for quick system diagnosis. Fig. 22 illustrates the layout and features of the LCD display panel and keypad.

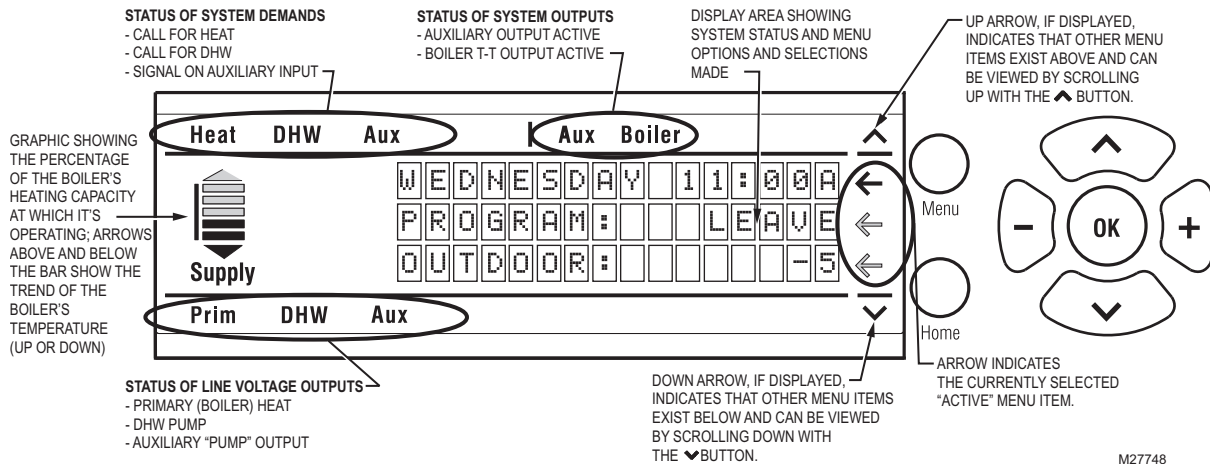

Fig. 22. LCD display and keypad layout.

LCD Display Navigation

This section describes how the keypad is used to navigate the LCD display and menus.

- The LCD displays up to three lines of text at a time. For menus with more than three lines, use the up and down buttons (^ or v) to scroll through the menu options.
- As the menu is scrolled up or down, the indicator arrow (←) shows which menu item is active.
- If the active menu item is part of a list of predefined options (e.g., Day of the Week) press the - or + button to scroll through the available options until the preferred option is displayed. The option is automatically saved when the indicator arrow is scrolled away from the value being edited.
- If the active menu item requires you to define a value (e.g., a setpoint), use the - or + button to decrease or increase the value until the desired value is displayed. The selection will be saved when the indicator arrow is scrolled up or down.

NOTES:

1. When setting times for the setback schedule, you must use the – or + buttons to change the time.
 2. The OK button, when pressed, defaults the time setting to “--:--” (midnight).
- If the active menu item leads to a further sub-menu, pressing the OK button displays the sub-menu options on the LCD. Scroll through this sub-menu to position the indicator arrow (←) beside the desired menu item to input or modify. Choose one of the options provided or input the desired value for the menu item. When satisfied, scroll to another item and your selection will be saved.
 - To define or modify another item within the same menu, scroll the up and down buttons (∧ or ∨) until the indicator arrow (←) is beside the desired option. Use the – or + buttons to set the value for that item.
 - To move back (up) one level within a menu, press the Menu button.
 - To return to the Home Page display, press the Home button.

NOTE: The AQ251 automatically returns to the Home Page display after 60 minutes of inactivity on the keypad.

HOME PAGE DISPLAY

The Home Page is the default view displayed on the AQ251 Control Panel's LCD screen.

There are two Home Page views - Simple and Detail.

- Simple view shows 3 lines of text and is a brief description of the system operation: Day, Time of Day, Current Program and Outdoor temperature.
- Detail view includes the same 3 lines, plus 8 lines of additional information, including Boiler Supply and Return temperatures, Boiler Supply Target temperature, Zone Demand and Zone Count, and DHW temperature (if configured for DHW sensor use). Detail view is the factory default setting for the Home Page.

The choice of the Simple or Detail Home Page view is made from the USER MENU > PREFERENCES/TIME>HOMEPAGE menu option.

The Home Page, together with the System Status information (a selection from the User Menu), provides a service contractor extensive diagnostic information for troubleshooting the installation.

NOTES: Home Page display upon restart after a power failure of more than four hours:

1. Upon restarting the AQ251 following a power disruption of greater than 4 hours, the message PLS SET DAY/TIME OF DAY displays on the top line of the Home Page screen. The message disappears after the DAY and TIME OF DAY are updated.
 - If the power failure parameter is set to Backlight (USER MENU > PREFERENCES), the LCD backlight flashes repeatedly, along with the message.
2. The AQ251 starts up with its clock settings as: DAY = MONDAY, TIME OF DAY = 12:00 midnight, and program = OCCupied.
3. Until the DAY and TIME OF DAY settings are adjusted, the control remains in permanent setpoint (comfort) mode.
4. When the DAY and TIME OF DAY settings are adjusted, the AQ251 follows the four programs of WAKE, LEAVE, RETRN (return), and SLEEP.

Refer to “Home Page” on page 23 in the “Appendix” for illustrations of the Simple and Detail displays.

Programming the AQ251

Program the AQ251 by using the keypad and LCD display to select parameters from the User and Installer menus. Refer to Fig. 22 on page 16 for an illustration of the LCD screen and keypad.

NOTE: The figures in “Menu Structure” on page 38 provide a graphical layout of the AQ251’s User and Installer menus.

When a new AQ2000 component is connected on the AQUATROL network, it will be seamlessly integrated in the system after a few seconds. If one or more components are disconnected or stop providing data to the network, a message will appear on the System Status display until the fault is corrected.

User Menu

The User Menu is intended for use by the building owner to choose the LCD display preferences, Zone Settings (including setpoint temperatures and setback times for each zone), and temperatures for the WAKE, LEAVE, RETRN (return), and SLEEP programs.

The Home Page and User Menu allow the building owner to:

- View the status of the system.
- Set up preferences for how the system information is displayed.
- Set the setpoint temperatures for each zone.
- Program times of the day when the system will set back the temperatures for the WAKE, LEAVE, RETURN, and SLEEP programs.

NOTE: If there are any problems with the system’s operation, the AQ251 displays error codes on the System Status Page display of the LCD panel. For details on these, refer to “Troubleshooting” on page 20.

TO ACCESS THE USER MENU:

Press the Menu button on the keypad at any time to access the User Menu.

Refer to Table 5 on page 24 in the “Appendix” for all of the User Menu options for the AQ251 Control Panel, the factory default values and permissible ranges for each option, and a brief description of each setting.

Installer Menu

The Installer Menu is used to:

- Set up and modify the Equipment Settings (for boiler operation, DHW management, zoning, auxiliary input/output operation, and options such as pump/valve exercise, freeze protection, and Save/Restore settings)
- Access the Test and Purge functions to facilitate quick and simple commissioning of the hydronic system.

TO ACCESS THE INSTALLER MENU:

1. Press the Home button to return to the Home Page display.
2. Press and hold the OK button for 3 seconds until the message, INSTALLER MODE – ARE YOU SURE?, displays.
3. Select YES.

- Press and release the OK button to display the Installer Menu.

Refer to Table 6 on page 30 in the “Appendix” for all of the Installer Menu options for the AQ251 Control Panel, the factory default values and permissible ranges for each option, and a brief description of how each setting affects the AQ251’s operation.

5 TEST AND CHECK OUT THE INSTALLATION

Startup

IMPORTANT

Apply power to the AQ251 Control Panel only after all of the AQ2000 SERIES components (Control Panel, thermostats, sensors, Zoning Panels) have been connected to the other equipment in the hydronic heating system (boiler, zone valves or pumps, DHW, Aquastat, etc.).

When powered, the AQ251 Control Panel begins its start-up routine, establishing communication with all other AQ2000 Series components on the AQUATROL network.

Test

The TEST feature enables the installer to checkout all of the system’s outputs, sensors, and zone equipment as part of system commissioning (Checkout).

The TEST operation is accessed from the Installer Menu option EQUIPMENT SETUP >TEST AND PURGE. To begin testing the installation, position the indicator arrow (←) beside the equipment group to be tested (OUTPUTS, SENSORS, or ZONES and press the OK button.

Test Outputs

- When TEST OUTPUTS is selected, the AQ251 LCD displays a list of all outputs that can be tested. To select an output to test, position the indicator arrow (←) beside that output and press the + button to activate the output’s relay. As each output is activated, a word icon for that output is displayed at the top or bottom of the LCD display (refer to Fig. 22 on page 16). The test routine activates the output relay until the – button is pressed to turn off that output.
- To test additional outputs, navigate the list using the up and down arrows (▲ or ▼), position the indicator arrow (←) beside that output and press the + button to begin testing. Press the – button to de-activate the output relay and stop its test.
- Any combination of outputs can be activated at the same time when testing the outputs.
- When finished testing the outputs, press the Menu button to return to the TEST AND PURGE sub-menu.

Test Sensors

When TEST SENSORS is selected, the AQ251 LCD displays the temperature that each of the SUPPLY, RETURN, SECONDARY and OUTDOOR sensors is measuring. If a sensor is malfunctioning or is not properly connected to the AQUATROL network, the value “- -” displays beside that sensor on the LCD, instead of its temperature. If any of the sensors reports a temperature that is illogical, investigate further by referring to “Troubleshooting” on page 20.

Test Zones

- When TEST ZONES is selected, the Installer can test all space heating zones connected to the AQ251 simultaneously or individually.
- If zones are tested simultaneously (TEST ALL ZONES), all zone outputs energize immediately (with a delay of 1/10th of a second between each pump or valve to minimize the chance of electrical circuit overloads caused by the inrush currents from the pumps’ motors).
- A zero (0) displayed after a zone’s ID address (e.g., Zone A1 0, A2 0, A16 0) indicates that the AQ251 Control Module has received confirmation that the zone’s pump or valve is closed, or OFF. Similarly, a one (1) displayed after a zone’s ID address (e.g., Zone A1 1, A2 1, A16 1) indicates that the AQ251 has received confirmation that the zone’s pump or valve is open, or ON.
 - For zone pumps or zone valves without end-switches, a 1 is displayed as soon as the pump is energized.
 - For zone valves with end-switches, a 1 is displayed only after the valve’s end switch makes or the valve’s Time To Open delay has expired (for use with 2-wire valves).
- To test zones individually, position the indicator arrow (←) beside a selected zone. Press the + button to energize it, and press the – button to de-energize it. As each zone is tested, the Status LED on the Zoning Module associated with that zone illuminates. To test additional zones, position the indicator arrow (←) beside the zone to be tested, Press the + button to energize the zone’s pump or valve, and then press the – button to de-energize it.
- Any combination of zones can be activated at the same time when testing the zones.
- When finished testing the zones, press the Menu button to return to the TEST AND PURGE sub-menu.

Checkout

- From the Installer Menu, select Boiler Settings and reduce the Warm Weather Shut Down (WWSD) temperature setting until it is disabled and the display shows “- -”. This way, the WWSD will not interfere with the zone operation during checkout.
- Turn down the DHW Aquastat, if present, to avoid interfering with space heating control operation.
- Turn up the setpoint of one of the thermostats associated with the Boiler (Primary) loop.
 - The zone valve or pump associated with that zone turns on.
 - The Boiler T-T relay activates (Boiler displays in the demands section of the LCD screen), and the Boiler pump relay activates (PRIMary displays in the outputs section of the LCD screen).

NOTE: See Fig. 22 on page 16 for the demands and outputs display areas on the LCD.

- c. Depending on the settings for the AUX.PUMP (line voltage-rated dry contacts) and the AUX OUT (low voltage-rated dry contacts), either or both of these relays may also close.
4. Turn down the setpoint of one thermostat. The zone valve or pump associated with that zone should turn off. The Boiler T-T and Boiler pump relay outputs should be de-activated.
5. Repeat steps 3 and 4 for all zones to verify each zone is operating correctly. Thermostats may be exercised individually or all together to accelerate the check out process.
6. Turn up the DHW Aquastat to simulate a call for hot water.
 - a. If the DHW device is a pump, the DHW relay output energizes immediately. The Boiler pump relay remains off.
 - b. If the DHW device is a valve, the Boiler pump relay energizes after a delay to allow the zone valve to fully open. This delay is selected from the EQUIPMENT SETUP>DHW>DHW VLV.OP menu option.
- c. Turn up the setpoint of one of the AQ1000 zone thermostats.
 - (1) If the DHW relay is configured to control a pump, and DHW PRIOrity is selected, the Boiler and the associated zone pump's relay remain off.
 - (2) If the DHW relay is configured to control a valve, and DHW PRIOrity is selected, the Boiler pump activates after a delay for the DHW zone valve to open, but the associated zone relays remain off.
 - (3) If DHW PRIOrity is disabled, space heating zone pumps and valves should operate during a call for DHW.
7. Turn down the DHW Aquastat to end the call for hot water. Space heating operation should continue (if DHW priority is disabled) or resume (if DHW PRIOrity is enabled).

6 PURGE AIR FROM ALL SYSTEM AND ZONE PIPING

The PURGE operation on the AQ251 Control Panel allows the installer to purge all zones (loops) sequentially, or each zone individually, for a period of time, PURGE TIME, which selected from the EQUIPMENT SETUP >TEST AND PURGE > PURGE submenu. The purge time can be adjusted in increments of 1 minute, up to a maximum of 30 minutes per loop to be purged.

After you have defined which loops to purge (all loops, or an individual loop) and for how long (using the AQ251's menus), position the indicator arrow (←) beside the START PURGE

option and press the OK button. The START PURGE display will change to STOP PURGE and the AQ251 display begins counting down the time remaining for the purge cycle.

Purging All Loops

When the purge time has elapsed for the first loop, the control proceeds to the next loop and performs the purge operation on each loop in sequential order. After all selected loops have been purged, the display shows PURGE COMPLETED.

7 DOCUMENT AND KEEP A RECORD OF ALL SYSTEM SETTINGS

After the AQ251 Series Control Panel and any AQ255/AQ257 Expansion Zoning Panels have been set up and the entire hydronic installation is operating properly, it is important to document all the system settings for future reference.

Job Records

All AQ2000 Series Panels are shipped with Installation Job Records for documenting these settings. These should be filled out completely and saved in the Installing Contractor's files.

NOTES: There are two classes of settings used by the AQ251 to control the operation of the heating system, Zone Settings and System (or Equipment) Settings. Both types of settings are stored in non-volatile memory and are not lost following an extended power disruption.

WHEN USING AQ1000 THERMOSTATS

1. Zone Settings are designed to be adjustable by the user or the installer and are stored in the faceplate of each zone's AQ1000 thermostat. These settings are not saved with the SAVE SETUP operation. If

the faceplates of two AQ1000 thermostats are switched, the settings (setpoints, zone minimum, zone maximum, etc.) will also be switched.

2. System Settings are designed to be adjustable only by the system installer and are stored in the AQ151 Control Module. These are the settings that are saved with the SAVE SETUP operation.

SAVE Feature

In addition to the hardcopy Installation Job Records, the AQ251 Control Panel has a convenient SAVE feature that allows the installing contractor to save the specific equipment setting for this installation in the AQ251's memory for future recall, in case the system's settings are inadvertently changed. This feature is found in the EQUIPMENT SETUP > SAVE/RESTORE sub-menu.

There are three levels of settings in the AQ251's memory – CURRENT, FACTORY and SETUP.

- **CURRENT** settings are the settings that are currently displayed in any of the menus and are the settings that the AQ251 uses to operate. Any time a value is changed in any of the menus, the CURRENT settings are changed and these new settings are instantly used by the AQ251 Control Panel.
- **FACTORY** settings are the default values loaded at the factory and are the starting point for programming the AQ251. These values are permanently stored in memory

and cannot be over-written or erased. The AQ251 can be restored to factory settings through the RESTORE FACTORY option in the SAVE / RESTORE sub-menu. A warning prompt, RESTORE FACTORY—ARE YOU SURE?, displays and YES or NO must be chosen before proceeding. If YES is selected, the FACTORY settings are copied to the AQ251's CURRENT settings and the Control Panel begins to operate with these values immediately.

- **SETUP** settings are the specific settings for this installation which an installer has saved after the AQ251 is set up and operating well. These are saved for future recall, in case the system's settings are inadvertently changed.
 - To save this installation's settings for the first time, go to the EQUIPMENT SETUP > SAVE/RESTORE sub-menu. Position the indicator arrow (←) beside SAVE SETUP and press OK. This saves the current system settings to the SETUP values.
 - To retrieve the SETUP values at any time in the future, go to the EQUIPMENT SETUP > SAVE / RESTORE sub-menu and select RESTORE SETUP to load those values into the AQ251 as the CURRENT settings. The system will now operate according to these retrieved settings.
 - If the current settings are modified after a RESTORE SETUP operation is performed, simply select SAVE SETUP again to overwrite these new settings into the SAVE settings memory.



CAUTION

If you change any system settings after a RESTORE SETUP operation, you change the current settings that the AQ251 uses as its basis of operation.

TROUBLESHOOTING

The following information helps the installer correctly identify system problems, making troubleshooting much faster.

Table 3 and Table 4, beginning on page 22, describe the possible error codes and status notices that can be communicated on the AQ155 / AQ157 Zoning Modules' diagnostic LEDs.

System Status Information

To aid in troubleshooting hydronic systems controlled by an AQ251, the operational status of the system is shown on the System Status page. Status notices and error messages display here as appropriate, i.e., only those that are pertinent to the system's current operation will be displayed. See Table 4 on page 22 for a complete list of status notices and error messages. The System Status page is available from the User Menu.

When a new AQ2000 component is connected on the AQUATROL network, its settings are communicated to the AQ251 Control Module within 10 seconds of being connected. If the component is an AQ1000 thermostat, the setpoints for that zone thermostat can be modified from the AQ251 Control Module as soon as it is recognized.

When an AQ1000 thermostat is disconnected from the AQUATROL network, a message displays on the System Status page of the AQ251 indicating "Lost Zone A-xx", where

"xx" is the specific identity, or address, of the lost zone. This helps the servicing contractor quickly identify the lost zone and fix its wiring to re-establish communication with the AQ251 Control Module.

This diagnostic information is very valuable and the System Status page is the first place a contractor should look for information when troubleshooting system problems.

Communications Loss

Because all AQ2000 Series components communicate with each other via the dedicated AQUATROL network when controlling a hydronic system, one possible failure mode of the AQ251 would be loss of communication between the AQ1510 Control Module and any connected Zoning Modules, or between a Zoning Module and any zone thermostats connected to the AQUATROL network. In general, the Control Module:

- Periodically tries to re-establish communication with any lost components on the network.
- Initializes any component that re-establishes its communication.
- Displays an error code on the AQ251's System Status page, until the error is corrected and/or communication is re-established.

Control Module Reaction

When the AQ1510 Control Module loses communication with any number of zones for more than one minute (as long as there is at least one zone communicating on the AQUATROL network), the AQ251 continues to deliver heat to the other non-communicating zones.

When communication is lost with all zones, the AQ251 enters BOILER FREEZE PROTECTION mode, in which it fires the boiler and then activates the Boiler (supply) pump and zone equipment for a period of 10 minutes every hour. This should provide sufficient heat to the system to prevent a building from freezing up until communication is re-established between the AQ2000 Series components.

BOILER FREEZE PROTECTION mode is disabled when the outdoor temperature is above the warm weather shutdown (WWSD) temperature setting.

Zoning Module Reaction

When a Zoning Module loses communication with the Control Module (as long as there is at least one other Zoning Module communicating with the Control Module), the Zoning Module operates its pumps or valves in a conventional, non-synchronized zoning fashion. That is, it operates according to the demands from the thermostats, without zone synchronization or waiting for permission from the AQ151 Control Module to operate. This allows the zones to extract any heat provided by the boiler.

When using AQ1000 thermostats and communication is lost between a Zoning Module and any of its thermostats, that zone enters Single Zone Freeze Protection mode. In this mode, the zoning equipment is operated for an amount of time equal to one-half of the maximum demand of all other zones on the network. This helps prevent the lost zone from freezing. This is especially helpful if a zone's thermostat is removed from the wall while a room is being painted. When used with 2-stage thermostat operation, only the first stage will be activated in the freeze protection mode.

When using digital, non-communicating thermostats other than the AQ1000, the Single Zone Freeze Protection is disabled for those zones.

Single Zone Freeze Protection mode is disabled when the outdoor temperature is above the warm weather shutdown (WWSD) temperature setting.

The AQ251 provides Zoning Module diagnostic information via the DIAGNOSTIC LEDs located above the DIP switches on its Zoning Module(s), as well as on the System Status menu of the LCD display.

If a zone becomes disconnected from the Control Module or is malfunctioning (i.e., lost), this can be seen in the ZONE COUNT value on the AQ251's Home Page display (Detail view only). The ZONE COUNT represents the number of zones on the AQUATROL network at any given time (the second stages of a heating zone is also counted as a zone). When a zone is lost, the ZONE COUNT decreases by one. Because an installer knows how many zones are installed, if there is a difference between the actual number of installed zones and the ZONE COUNT, the installer will know to look for the zone(s).

The identity of lost zones displays in the System Status page as LOST ZONE A-X:

- A identifies the Control Module of the lost zone, and B, C, or D identify an AQ25400B Add-A-Temperature Expansion Control Panel. This prefix can be set or changed on the AQ254 Panels.
- X identifies the lost zone (1 through 16).

Boiler Freeze Protection

(not network communication-related)

If the boiler supply temperature sensor measures 50°F (10°C) or less, the boiler fires and the boiler pump, secondary pump etc. operate until the target temperature is achieved, as measured by the supply temperature sensor. This target temperature is the reset temp (if the boiler RESET parameter = OUTDOOR). Or, it is the AQ251's BOILER HIGH LIMIT (if the boiler RESET parameter = LOAD or NONE). DHW and Heat Demand calls are ignored when the system is in freeze protection mode.

Power Disruption

The AQ251's system and thermostat parameters are stored in non-volatile memory and are updated as they are changed.

When a power disruption occurs, the system configuration is retained in memory. When power is restored, the AQ251 Control Panel enters auto-detection mode, reads its previously-stored settings, and initializes all AQUATROL network components according to their saved parameters.

Power Disruption Greater Than 2 Hours

If a power disruption lasts for more than 2 hours, the AQ251 will have discharged its internal super capacitor, and the DATE and TIME OF DAY settings will need to be reset.

Upon restart, the AQ251 displays its clock settings as: YEAR = 2008, MONTH = JAN, DATE = 1. The message PLS SET DAY/TIME displays and optionally, the AQ251's backlight flashes repeatedly. This displayed message continues until the DATE and TIME OF DAY are updated. The AQ251 remains permanently in OCCUPIED (or Comfort) mode until the DATE and TIME OF DAY are updated.

Table 3. AQ155 / AQ157 Zoning Module LED Display and System Condition.

DIAGNOSTIC LED Status		System Condition	Action Required
Steady (no blinking)		No system problem detected	None
Fast blinking (4 blinks per second)		Auto Test is in operation	None. Allow the control to finish its Auto Test routine.
Slow blinking (2 blinks every 3 seconds)		Auto Test has been paused.	Press the Test button to resume the Auto Test routine.
Coded blinking = ERROR	2 blinks, then pause	Freeze protection activated across the entire AQUATROL network	All zones have lost communication with the Control Module. Check B–B wiring between the Control Module and each Zoning Module.
	3 blinks, then pause	Communication lost with <u>all</u> thermostats on the Zoning Module	Check thermostat wiring to each Zoning Module.

Table 4. LCD Status Notices and Error Messages.

LCD Display	Parameter	Meaning
BOILER:	EM SHUT	Boiler is disabled, because the AQ251 is in Emergency Shut Down mode.
	FRZ PROT	Boiler freeze protection activated: <ul style="list-style-type: none"> • Communication between Control Module and Zoning Module has been lost for more than 1 minute or • Boiler supply temperature is less than 50°F (10°C)
	HEAT DHW	Boiler is active to serve DHW.
	HEATING	Boiler is active to serve zones.
	IDLE	Boiler is not active.
	INIT	Boiler contacts (terminals 17 and 18) on the AQ151, which are connected to the boiler's T-T terminals, have been shorted and the boiler is beginning its firing sequence.
	INST PURG	Boiler is active while the AQ251 is conducting the PURGE operation in the Installer Setup.
	INSTALL	Boiler is in ready mode during Installer Setup.
	PMP EXER	Boiler is disabled while the AQ251 is exercising all pumps and valves connected to the AQUATROL network.
	POST PURG	Boiler is active with Post Purge operation and is sending the purged water to the Boiler (Primary) loop.
PURGE DHW	Boiler is active with Post Purge operation and is sending the purged water to the DHW tank.	
CALL FOR COOL	n/a	At least one zone with a programmable thermostat requires cooling.
CALL FOR DHW	n/a	The DHW requires heat.
CALL FOR HEAT	n/a	At least one zone requires heat.
CWSD ACTIVE	n/a	Zone calls for cooling are not served because CWSD (Cold Weather Shutdown) is in progress.
DHW DISABLE	n/a	DHW call is not served because it is disabled.
LOST ZONE A-1 ... LOST ZONE D-16	n/a	Lost communication with a zone (A-1 to A-16, B-1 to B-16, C-1 to C-16, or D-1 to D-16).
NO DHW PROBE	n/a	No DHW sensor connected or it is defective.
NO OUTDOOR PROBE	n/a	No outdoor sensor connected or it is defective.
NO RETURN PROBE	n/a	No return sensor connected or it is defective.
NO SUPPLY PROBE	n/a	No supply sensor connected or it is defective.
SHORT CYCLE PROT	n/a	There is a call for heat, but less than two minutes have elapsed since the last firing of the boiler (prevents short cycling).
VALVE INIT	n/a	Motorized mixing valve controlling the secondary loop is being initialized and repositioned (opening or closing) to meet the secondary loop target temperature.
WATER READY	n/a	Boiler Supply Water temperature is at or above the target temperature calculated by the AQ251.
WWSD ACTIVE	n/a	Zone calls for heat is not served because WWSD (Warm Weather Shutdown) is in progress.

APPENDIX

The appendix provides AQ251 Control Panel user interface information for the:

- The Home Page
- Programming menus (User and Installer)
- Programming menu structure (User and Installer). See page 38.

Home Page

The Home Page is the default display for the control panel. It provides general information on system water and outdoor temperatures, program schedule mode and day / time of day.

The Home Page display may be Simple (3-line) or Detailed (8-line), as illustrated in Fig. 23. The Home Page display type is configured from the Installer Menu.

Press the Home button on the keypad to display the Home Page.

NOTES:

1. PLS SET DAY/TIME displays after a power outage of more than 4 hours.
2. PROGRAM displays the current active program (Leave, Return, Sleep, Wake, Occ, or Unocc).
3. TARGET displays the current temperature or indicates the system is in a warm water shutdown (WWSD) status.
4. When “- -” is displayed instead of a temperature value (e.g., TARGET: - -), this means that there is no call for heat from either space heating, DHW, or Heat Demand zones at the moment.

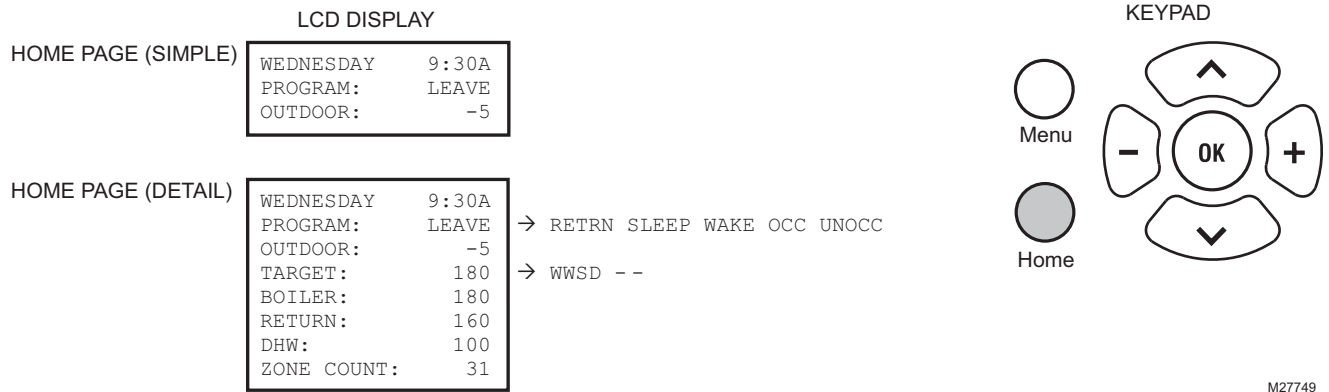

Fig. 23. Home Page display (Simple and Detail) and keypad.

Programming Menus

There are two programming menus, User and Installer. The Installer Menu begins on page 30.

User Menu

The User Menu can be accessed at any time by pressing the Menu button on the keypad.

This menu allows the building owner to:

- View the System Status and Statistics.
- Set the display preferences, date, and time.
- Edit the Zone settings, including setpoint temperatures for each zone.
- Edit the Setback temperatures for each zone for the WAKE, LEAVE, RETRN (return), and SLEEP programs.

Refer to Table 5 beginning on page 24 for the following User Menu selections:

- System Status (page 24)
- Preferences/Time (page 24)
- Zone Settings (page 26)
 - All zones
 - Single zone for Ambient, Floor, or Ambient/Floor settings
- Program Settings (page 28)
- Statistics – refer to page 29.

NOTE: An illustration of the complete User Menu is on page 38.

Table 5. User Menu.

Menu Option	Range	Factory Default	Description
SYSTEM STATUS		Identifies what is happening within the system.	
See Table 4 on page 22	n/a	n/a	Multiple status and alarm messages can display on this page. This diagnostic information is for troubleshooting purposes. However, only the status and messages pertinent to the system's current operating condition will display.
PREFERENCES		Allows you to set up the AQ251 Control Panel with preferred display, time, date, and temperature settings.	
BOILER UNITS	°F or °C	°F	Choice of temperature units (F or C) for displaying temperatures on the AQ251 LCD display.
ZONE UNITS	°F or °C	°F	Choice of temperature units (F or C) for displaying temperatures (on the AQ1000 zone thermostats).
TIME DISP	12H or 24H	12H	Choice of time format display: 12 hour format (e.g., 2:00 P) or 24 hour format (e.g., 14:00).
D.S.T.	ENABLE or DISABLE	ENABLE	Enables / disables automatic change to and from Daylight Savings Time.
YEAR	2000 - 2099	2008	Select the year when the control is commissioned.
MONTH	JAN, FEB, MAR, APR, MAY, JUN, JUL, AUG, SEP, OCT, NOV, DEC	JAN	Select the month of the year when the control is commissioned.
DATE	01 to 31	01	Select the date (01-31) of the month when the control is commissioned.
DAY	MONDAY, TUESDAY, WEDNESDAY, ... SUNDAY	MONDAY	Select the day of the week when the control is commissioned.
TIME	00:00A to 12:59P (00:00 to 23:59)	12:00A (midnight)	Select the time of day when the control is commissioned. You can change the time with the + and – buttons, just as with a clock radio.
HOME PAGE	SIMPLE or DETAIL	DETAIL	Select the 3 line (Simple) display or the 10 line (Detail) display for the Home Page.
BACKLIGHT	AUTO or ON	AUTO	<ul style="list-style-type: none"> • Auto mode = backlight illuminates when any button on the display is pressed. It turns off after 1 hour. • ON mode = backlight stays on constantly.
POWER FAILURE NOTICE	BACKLIGHT or MSG.ONLY	BACKLIGHT	<p>The building owner can be notified in one of two ways that the AQ251's DATE and TIME OF DAY settings need to be reset:</p> <ol style="list-style-type: none"> 1. By displaying the message, PLS SET DAY/TIME, on the first line of the Home Page 2. By repeated flashing of the AQ251's LCD backlight and displaying the message PLS SET DAY/TIME, on the first line of the Home Page

Table 5. User Menu. (Continued)

Menu Option	Range	Factory Default	Description
ZONE SETTINGS	Displays all information pertaining to the selected zone(s). There are four possible sub-menu displays (available only with AQ1000 thermostats): 1. EDIT ALL ZONES 2. EDIT SINGLE ZONE - Ambient Style (see page 26) 3. EDIT SINGLE ZONE - Floor Style (see page 27) 4. EDIT SINGLE ZONE - Ambient/Floor Style (see page 27)		
EDIT ALL ZONES	YES or NO	NO	Prompts with EDIT ALL ZONES ARE YOU SURE? Selecting YES displays the following options:
SETPOINT	Between SETPOINT MIN and SETPOINT MAX	70°F (21°C)	Target temperature set for the zone.
SETBACK	0°F to 16°F (0°C to 9°C)	7°F (4°C)	Amount of temperature (number of degrees) setback from occupied to unoccupied modes for this zone.
SETPOINT MAX	41°F to 100°F (5°C to 38 °C)	100°F (38°C)	Maximum setpoint temperature allowed for this zone's thermostat. The SETPOINT MAX cannot be set below the SETPOINT MIN setting.
SETPOINT MIN	41°F to 100°F (5°C to 38 °C)	41°F (5°C)	Minimum setpoint temperature allowed for this zone's thermostat. The SETPOINT MIN cannot be set above the SETPOINT MAX setting.
FLOOR LIMIT HI ^a	41°F to 100°F (5°C to 38 °C)	100°F (38°C)	Maximum floor temperature allowed for a given zone that is controlled by a floor / slab sensor connected to that zone's AQ1000 thermostat. At Floor MAX, the zone equip is turned off. The FLOOR MAX cannot be set below the FLOOR MIN setting.
FLOOR LIMIT LO ^a	41°F to 100°F (5°C to 38 °C)	41°F (5°C)	Minimum floor temperature allowed for a given zone that is controlled by a floor / slab sensor connected to that zone's AQ1000 thermostat. At Floor MIN, the zone equip is energized. The FLOOR MIN cannot be set above the FLOOR MAX setting).
SETPOINT VACANCY HEAT ^b	Between SETPOINT MIN and SETPOINT MAX	41°F (5°C)	Target heating temperature for the zone when system is in VACANCY mode.
SETPOINT VACANCY COOL ^b	Between SETPOINT MIN and SETPOINT MAX	100°F (38°C)	Target cooling temperature for the zone when system is in VACANCY mode. Only displays when cooling is enabled for that zone.
CHANGEOVER ^b	2°F to 9°F (1°C to 5°C)	2°F (1°C)	Temperature deadband that determines the changeover from heating to cooling and from cooling to heating: <ul style="list-style-type: none"> The thermostat switches from heating to cooling mode when the indoor temperature is <u>higher</u> than the setpoint by more than the changeover band setting for 15 minutes. The thermostat switches from cooling to heating mode when the indoor temperature is <u>lower</u> than the setpoint by more than the changeover band setting for 15 minutes.
KEYBOARD	LOCK or UNLOCK	UNLOCK	Controls the zone thermostat's keyboard. <ul style="list-style-type: none"> If set to LOCK, settings cannot be changed at that zone's thermostat. If set to UNLOCK, the thermostat's settings can be changed within the respective limits.

Table 5. User Menu. (Continued)

Menu Option	Range	Factory Default	Description
EDIT SINGLE ZONE^c	Ambient Style — Selecting this menu item displays the following options:		
ZONE #A-X	A-1 to A-16 ... D-1 to D-16	A-1	Each zone on the AQUATROL network has a unique identity (address). This address consists of a Control Module ID and the Zone related to that controller. <ul style="list-style-type: none"> Module ID: The Boiler Controller is A, and the 1st through 3rd Add-A-Temperature Expansion Control Modules (i.e., AQ25400B) are B, C, and D. Zone: From 1 to 16 for each Module ID. <p>A total of four controllers (one Boiler Control Module and up to three Add-A-Temperature Expansion Control Modules), each having 16 associated zones can be connected on the AQUATROL network. The AQ251 Control Panel itself can control one Boiler loop water temperature and one secondary loop water temperature.</p>
ROOM TEMP	32°F to 158°F (0°C to 70°C)	n/a	Display only – Temperature measured by the zone thermostat.
SETPOINT	Between SETPOINT MIN and SETPOINT MAX	70°F (21°C)	Target temperature set for the zone.
H/C STATUS	HEAT or COOL	n/a	Display only – Status is received from each zone thermostat every 10 seconds.
SETBACK	0°F to 16°F (0°C to 9°C)	7°F (4°C)	Amount of temperature (number of degrees) setback from occupied to unoccupied modes for this zone
SETPOINT MAX	41°F to 100°F (5°C to 38 °C)	100°F (38°C)	Maximum setpoint temperature allowed for this zone's thermostat. The SETPOINT MAX cannot be set below the SETPOINT MIN setting.
SETPOINT MIN	41°F to 100°F (5°C to 38 °C)	41°F (5°C)	Minimum setpoint temperature allowed for this zone's thermostat. The SETPOINT MIN cannot be set above the SETPOINT MAX setting.
SETPOINT VACANCY HEAT	41°F to 100°F (5°C to 38 °C)	41°F (5°C)	Target HEATING temperature for the zone when system is in VACANCY mode
SETPOINT VACANCY COOL	41°F to 100°F (5°C to 38°C)	100°F (38°C)	Target COOLING temperature for the zone when system is in VACANCY mode. Only displayed when cooling is enabled for that zone.
CHANGEOVER	2°F to 9°F (1°C to 5°C)	2°F (1°C)	Temperature deadband that determines the changeover from heating to cooling and from cooling to heating: <ul style="list-style-type: none"> The thermostat switches from heating to cooling mode when the indoor temperature is higher than the setpoint by more than the changeover band setting for 15 minutes. The thermostat switches from cooling to heating mode when the indoor temperature is lower than the setpoint by more than the changeover band setting for 15 minutes.
KEYBOARD	LOCK or UNLOCK	UNLOCK	Controls the zone thermostat's keyboard. <ul style="list-style-type: none"> If set to LOCK, settings cannot be changed at that zone's thermostat. If set to UNLOCK, the thermostat's settings can be changed within the respective limits.

Table 5. User Menu. (Continued)

Menu Option	Range	Factory Default	Description
EDIT SINGLE ZONE^c	Floor Style — Selecting this menu item displays the following options:		
FLOOR TEMP	32°F to 158°F (0°C to 70°C)	n/a	Display only. This is the temperature measured by the floor temperature sensor.
FLOOR SETPT	41°F to 100°F (5°C to 38 °C)	70°F (21°C)	This menu option displays only when the AQ1000 thermostat is set to FLOOR ONLY mode.
SETBACK	0°F to 16°F (0°C to 9°C)	7°F (4°C)	Amount of temperature (number of degrees) setback from occupied to unoccupied modes for this zone.
SETPOINT MAX	41°F to 100°F (5°C to 38 °C)	100°F (38°C)	Maximum setpoint temperature allowed for this zone's thermostat. The SETPOINT MAX cannot be set below the SETPOINT MIN setting.
SETPOINT MIN	41°F to 100°F (5°C to 38 °C)	41°F (5°C)	Minimum setpoint temperature allowed for this zone's thermostat. The SETPOINT MIN cannot be set above the SETPOINT MAX setting.
SETPOINT VACANCY HEAT	41°F to 100°F (5°C to 38 °C)	41°F (5°C)	Target HEATING temperature for the zone when system is in VACANCY mode.
KEYBOARD	LOCK or UNLOCK	UNLOCK	Controls the zone thermostat's keyboard. <ul style="list-style-type: none"> • If set to LOCK, settings cannot be changed at that zone's thermostat. • If set to UNLOCK, the thermostat's settings can be changed within the SETPOINT MAX and SETPOINT MIN limits.
EDIT SINGLE ZONE^c	Ambient/Floor Style — Selecting this menu item displays the following options:		
ZONE #A-X	A-1 to A-16 ... D-1 to D-16	A-1	Each zone on the AQUATROL network has a unique identity (address). This address consists of a Control Module ID and the Zone related to that controller. <ul style="list-style-type: none"> • Module ID: The Boiler Controller is A, and the 1st through 3rd Add-A-Temperature Expansion Control Modules (i.e., AQ25400B) are B, C, and D. • Zone: From 1 to 16 for each Module ID. <p>A total of four controllers (one Boiler Control Module and up to three Add-A-Temperature Expansion Control Modules) each having 16 associated zones can be connected on the AQUATROL network. The AQ251 Control Panel itself can control one Boiler loop water temperature and one secondary loop water temperature.</p>
ROOM TEMP	32°F to 158°F (0°C to 70°C)	n/a	Display only. This is the temperature measured by the zone thermostat.
FLOOR TEMP	32°F to 158°F (0°C to 70°C)	n/a	Display only – Temperature measured by the floor temperature sensor.
SETPOINT	Between SETPOINT MIN and SETPOINT MAX	70°F (21°C)	Target temperature set for the zone.
H/C STATUS	HEAT or COOL	n/a	Display only – Status is received from each zone thermostat every 10 seconds.
SETBACK	0°F to 16°F (0°C to 9°C)	7°F (4°C)	Amount of temperature (number of degrees) setback from occupied to unoccupied modes for this zone.
SETPOINT MAX	41°F to 100°F (5°C to 38 °C)	100°F (38°C)	Maximum setpoint temperature allowed for this zone's thermostat. The SETPOINT MAX cannot be set below the SETPOINT MIN setting.
SETPOINT MIN	41°F to 100°F (5°C to 38 °C)	41°F (5°C)	Minimum setpoint temperature allowed for this zone's thermostat. The SETPOINT MIN cannot be set above the SETPOINT MAX setting.

Table 5. User Menu. (Continued)

Menu Option	Range	Factory Default	Description
EDIT SINGLE ZONE			
Ambient/Floor Style (continued)			
FLOOR LIMIT HI ^a	41°F to 100°F (5°C to 38 °C)	100°F (38°C)	Maximum floor temperature allowed for a given zone that is controlled by a floor / slab sensor connected to that zone's AQ1000 thermostat. At floor maximum, the zone equipment is turned off. The FLOOR MAX cannot be set below the FLOOR MIN setting.
FLOOR LIMIT LO ^a	41°F to 100°F (5°C to 38 °C)	41°F (5°C)	Minimum floor temperature allowed for a given zone that is controlled by a floor / slab sensor connected to that zone's AQ1000 thermostat. At Floor MIN, the zone equip is energized. The FLOOR MIN cannot be set above the FLOOR MAX setting.
SETPOINT VACANCY HEAT	41°F to 100°F (5°C to 38 °C)	41°F (5°C)	Target HEATING temperature for the zone when system is in VACANCY mode.
SETPOINT VACANCY COOL	41°F to 100°F (5°C to 38 °C)	100°F (38°C)	Target COOLING temperature for the zone when system is in VACANCY mode. Only displays when cooling is enabled for that zone.
CHANGEOVER	2°F to 9°F (1°C to 5°C)	2°F (1°C)	Temperature deadband that determines the changeover from heating to cooling and from cooling to heating: <ul style="list-style-type: none"> • The thermostat switches from heating to cooling mode when the indoor temperature is higher than the setpoint by more than the changeover band setting for 15 minutes. • The thermostat switches from cooling to heating mode when the indoor temperature is lower than the setpoint by more than the changeover band setting for 15 minutes.
KEYBOARD	LOCK or UNLOCK	UNLOCK	Controls the zone thermostat's keyboard. <ul style="list-style-type: none"> • If set to LOCK, settings cannot be changed at that zone's thermostat. • If set to UNLOCK, the floor thermostat's settings can be changed within the FLOOR MAX and FLOOR MIN limits.
PROGRAM SETTINGS			
Displays, and allows for editing of, the temperature setpoints for each of the four time periods (or programs) within a 24-hour period (WAKE, LEAVE, RETRN (return), and SLEEP).			
MODE	AUTO, OCC, or UNOCC	AUTO	<ul style="list-style-type: none"> • AUTO = Automatically follow the four time periods (or programs) within a 24 hour period, as set up in the Edit All Days or Edit Daily sub-menus. The four programs are WAKE, LEAVE, RETRN (return), and SLEEP. • OCC = Observe the program settings only for WAKE and RETRN (return). • UNOCC = Observe the program settings only for LEAVE and SLEEP.
EDIT ALL DAYS	ALL WAKE, ALL LEAVE, ALL RETRN, or ALL SLEEP	WAKE=6:00AM LEAVE=8:00AM RETRN=6:00PM SLEEP=10:00PM	Allows Installer to set the WAKE, LEAVE, RETRN (return), and SLEEP times once, and apply the settings to all 7 days. NOTE: The programs will be copied to the individual days only when the COPY TO ALL DAYS option is selected.
EDIT DAILY	WAKE, LEAVE, RETRN, or SLEEP	WAKE=6:00AM LEAVE=8:00AM RETRN=6:00PM SLEEP=10:00PM	Allows Installer to set the WAKE, LEAVE, RETRN (return), and SLEEP times for all 7 days individually.

Table 5. User Menu. (Continued)

Menu Option	Range	Factory Default	Description
STATISTICS		Displays the summary and zone relay activity (hours of operation or cycles since last reset).	
LAST DATA RESET	Max. 24,855 days (68 years)	2000 JAN 01	Date of last reset formatted as YYYY MMM DD.
BOILER FIRE ACTIV	Maximum of 596,523 hours (68 years)	0H	Hours of operation of the relay since last reset.
BOILER PUMP ACTIV	Maximum of 596,523 hours (68 years)	0H	Hours of operation of the relay since last reset.
DHW PUMP ACTIV	Maximum of 596,523 hours (68 years)	0H	Hours of operation of the relay since last reset.
AUX PUMP ACTIV	Maximum of 596,523 hours (68 years)	0H	Hours of operation of the relay since last reset.
AUX OUT ACTIV	Maximum of 596,523 hours (68 years)	0H	Hours of operation of the relay since last reset.
ZONE A-1 ACTIV	Maximum of 596,523 hours (68 years)	0H	Hours of operation of the zone's relay (e.g., zone A-1) since last reset. The zone Identifier is A-1 through D-16.

^a The FLOOR LIMIT values can be set in the User Menu of AQ251 Control Panel or the Installer Menu of the AQ1000 thermostat. These programming options only display when an AQ1000 thermostat is configured for Air/ Floor or Floor control operation. Refer to the AQ1000 thermostat Instruction Sheet.

^b Only available with AQ1000TP2 thermostats.

^c Only available with AQ1000 thermostats.

Installer Menu

The Installer Menu allows you to set up and modify system settings that typically would be adjusted by a trained installer. These include equipment settings (for boiler operation, DHW management, zoning, auxiliary input/output operation) and option settings, such as pump/valve exercise, freeze protection, and Save/Restore settings.

System statistics and the installer tools (Test and Purge) are also available from the Installer Menu.

The two Installer Menu options are:

- Equipment Setup – refer to Table 6
- Test and Purge – refer to Table 7 on page 36

NOTE: Illustrations of the complete Installer Menu begin on page 39.

To access the Installer Menu:

1. Press the Home button to return to the Home Page display.
2. Press and hold the OK button for 3 seconds until the message, INSTALLER MODE – ARE YOU SURE?, displays.
3. Select YES, then press and release the OK button to display the Installer Menu.

NOTE: To exit Installer Mode, select the Installer Exit menu option.

Table 6. Installer Menu – Equipment Setup.

EQUIPMENT SETUP			
Menu Option	Range	Factory Default	Description
BOILER SETTINGS	Installer-defined settings for the system design parameters (e.g., boiler supply and return temperatures, reset mode, and outdoor low temperature)		
HIGH LIMIT	12°F to 225°F (49°C to 107°C)	190°F (88°C)	Maximum temperature that the control can use as a target for the boiler supply water (HIGH LIMIT cannot be set below the LOW LIMIT setting).
LOW LIMIT	60°F to 180°F (15°C to 82°C)	150°F	Minimum temperature that the control can use as a target for the boiler supply water (LOW LIMIT cannot be set above the HIGH LIMIT setting).
BOILER DIFF	2°F to 41°F (1°C to 23°C) / AUTO	AUTO	The temperature differential used by the control when operating the boiler. The same differential is used for both the HIGH LIMIT and the LOW LIMIT. <ul style="list-style-type: none"> • If AUTO is selected, the differential is calculated automatically by the AQ251 to maximize comfort and minimize boiler short cycling. • If a specific boiler differential (BOILER DIFF) is selected, the AQ251 will apply 1/2 of this differential above the AQ251's HIGH LIMIT boiler setting and the other 1/2 below the HIGH LIMIT setting when controlling the boiler supply water temperature. • For example, if the High Limit = 190°F and the Boiler Diff = 10°F, the High Limit range becomes 185-195°F. NOTE: This formula also applies to the boiler differential around the AQ251's LOW LIMIT.
W.W.S.D.	-- 35°F to 100°F (2°C to 38°C)	70 °F (21°C)	Warm Weather Shut Down is the outdoor temperature above which the AQ251 will not allow hot water to be sent to a space heating zone. The boiler still operates to supply hot water to DHW or a setpoint (HEAT) demand. The WWSD feature can be disabled by reducing the WWSD temperature below 35°F (2°C), at which point the display will read "--". NOTE: Disabling WWSD is not advisable. This will increase the average reset temperature for the Boiler Supply water, resulting in higher energy consumption and less even heating.
RESET	OUTDOOR / LOAD / NONE	OUTDOOR	Selects the calculation method (algorithm) that the control uses to set the target temperature for the boiler supply and secondary loop supply water. Choose LOAD for buildings with high internal heat gains; otherwise use OUTDOOR.

Table 6. Installer Menu – Equipment Setup. (Continued)

EQUIPMENT SETUP			
Menu Option	Range	Factory Default	Description
BOILER SETTINGS (continued)			
OUTDOOR LOW	-60°F to 32°F (-51°C to 0°C)	10 °F (-12°C)	The lowest annual outdoor temperature for the location where the system is installed, also referred to as the Design Temperature. Typically used in the original heat loss calculations for the building, the OUTDOOR LOW temperatures for various cities in North America can generally be found in ASHRAE tables.
BOILER DSGN	80°F to 210°F (27°C to 99°C)	180°F (82°C)	The supply water temperature required from the boiler when the outdoor temperature is at the OUTDOOR LOW temperature.
MIN. RETURN	OFF / 80°F to 180°F (27°C to 82°C)	140 °F (60°C)	Minimum temperature (or OFF) that the control allows for water returning to the boiler. If the temperature of the boiler return water is below the selected temperature, <u>and</u> the AUX pump is set to operate as a boiler bypass pump (EQUIPMENT SETUP > AUXILIARY I/O > AUX.PUMP option is set to BYPASS), the AUX dry contacts close, allowing the separately-powered AUX pump to energize.
BOILER OPERATION			
CYCLES/HOUR	2 to 6	4	The number of heating cycles per hour that the control will operate the boiler.
FIRE DELAY	0 seconds to 3 minutes (in 5 second increments)	10 (seconds)	Time period that AQ251 control expects between closing the T-T relay and the boiler firing up. Referring to the boiler's instruction manual, set this value equal to the boiler's pre-purge time, if available for the boiler.
PURGE TIME	OFF, 10 seconds to 30 minutes (in 10 second increments)	30 (seconds)	Length of time the Boiler pump (or Boiler pump plus zone valve) will continue to operate (remain open) after the boiler stops firing. Adjustable from 10 seconds to 30 minutes or OFF.
EXERCISE	YES / NO	YES	Option can be set to YES or NO. When set to YES, all pumps and valves in the system are energized for 30 seconds, following a period of 2 weeks of no zone equipment activity. The boiler is not fired during this operation.
FREEZE PROT	YES / NO	YES	Option can be set to YES or NO. When set to YES, all pumps and valves in the system are energized for 4 minutes every hour. The boiler is operated at high fire during this operation.
10V MOD. SELECT	Operating settings for the analog 0-10V (2-10V) modulating signal		
10V MOD	0-10V / 2-10V	0-10V	The analog signal provided by the control to the mixing valve or variable speed pump is proportional to the degree of opening of the valve or the speed of the pump. It is opened fully at 10V and closed fully at either 0V or 2V, depending on the setting chosen. The pump is running at maximum speed at 10V and completely stopped at 0V or 2V.
USAGE	NONE / BOILER	NONE	This setting assigns the device which the analog signal will drive. The NONE option disables a signal from the 10V output.

Table 6. Installer Menu – Equipment Setup. (Continued)

EQUIPMENT SETUP			
Menu Option	Range	Factory Default	Description
DOMEST.HOT WATER	Settings that the AQ251 uses to manage Domestic Hot Water generation		
DHW	ENABLE / DISABLE	ENABLE	Identifies whether Domestic Hot Water Management function is enabled. DHW is typically disabled only if a separate source of domestic hot water (e.g., oil, or gas-fired hot water heater) is used.
DHW PRIO	YES / NO	NO	Displays only if DHW = ENABLE. Selects whether DHW generation can take priority over space heating. If yes, set to YES; if not, set to NO.
PRIO.OVER.	YES / NO	YES	Displays only if DHW PRIO = YES. Selects whether (following a 30 minute uninterrupted call for DHW Demand) the priority given to DHW generation can be overridden to minimize the chance of freeze up or excessive cool down of the space heating zones. <ul style="list-style-type: none"> • YES = On = Allow DHW Priority override. • NO = Off = Do not allow DHW Priority override. If DHW Priority is selected, Honeywell strongly recommends setting the DHW PRIOR.OVER to YES.
DHW DEVICE	PUMP / VALVE	PUMP	Displays only if DHW = ENABLE. Selects whether the DHW loop is supplied by a zone valve or zone pump.
DHW VLV.OP	0 - 230 seconds (in 5 second increments)	15 (seconds)	Displays only if DHW DEVICE = VALVE. Time required for the DHW zone valve to fully open before boiler loop pump is energized. The 15 second default is typical for motorized valves.
DHW PURGE	YES / NO	YES	Displays only if DHW = ENABLE. Selects whether or not a purge should be applied after a DHW demand has been served. If YES is selected, the DHW pump or valve is kept running for the amount of time programmed in the PURGE TIME option of the BOILER OPERATION menu.
DHW SENSOR	YES / NO	NO	Selects whether or not the Return sensor will be used as a DHW tank sensor. YES = use as the DHW sensor.
DHW SETPOINT	- - 60°F to 160°F (16°C to 71°C)	140°F (60°C)	Displays only if DHW SENSOR = YES. “- -” means Off (not used). Target temperature set for the DHW tank.
DHW DIFF	- - 5°F to 40°F (2.5°C to 22°C)	20°F (-7°C)	Displays only if DHW SENSOR = YES. “- -” means Off (not used). <ul style="list-style-type: none"> • A call for DHW begins when the measured DHW temperature = DHW SETPOINT - DHW DIFF and ends when the DHW temperature = DHW SETPOINT. • For example, if the DHW setpoint = 140°F and the DHW Diff = 20°F, a call for DHW begins when the DHW temperature falls below 120°F and ends when the DHW temperature increases to 140°F.
DHW VACANCY	- - [41°F + DHW DIFF] to 160°F ([5°C + DHW DIFF] to 71°C)	45°F (7°C)	Displays only if DHW SENSOR = YES. “- -” means Off (not used). Target DHW temperature when system is in VACANCY mode
ZONING	Settings which the AQ251 uses specifically for Zone operation		
HT DMND PRIO	YES / NO	NO	Selects whether a HEAT DEMAND (device connected to the Heat terminals on the AQ control module) can take priority over space heating. If yes, set to YES; if not, set to NO. <ul style="list-style-type: none"> • If both DHW Priority and Heat Demand Priority are set to YES and both are active at the same time, DHW Priority takes priority over Heat Demand Priority.

Table 6. Installer Menu – Equipment Setup. (Continued)

EQUIPMENT SETUP			
Menu Option	Range	Factory Default	Description
PRIO.OVER	YES / NO	NO	Displays only if HT DMND PRIO = YES. Selects whether (following a 30 minute uninterrupted call for Heat Demand) the priority given to the Heat Demand can be overridden to minimize the chance of freeze up or excessive cool down of the space heating zones. <ul style="list-style-type: none"> • YES = On = Allow Heat Demand Priority override. • NO = Off = Do not allow Heat Demand Priority override.
ZONING VALVES TIME TO OPEN	0 - 230 (seconds)	15 (seconds)	Time required for the zone valves installed on space heating zones to fully open.
AUXILIARY I/O	Settings which the AQ251 uses to control the system based on input to the AUX. IN terminals or to control the activation of the AUX.OUT and AUX.PUMP outputs.		
AUX.IN (optional)	SETBACK / VACANCY / EM. SHUT / NONE	SETBACK	Based on the setting chosen, the AQ251 sets the system in one of 3 different levels of setback for as long as the Aux. In terminals are shorted. Refer to instruction sheet for AQ1000 thermostat (69- 2005EF) for setting the Vacancy (Freeze Protection) temperature setpoint.
AUX.OUT (optional)	BOILER / SETBACK / ZONE OP. / ALARM / AUX.IN / DHW IN / HEAT IN / HT DMND / COOL / NONE	BOILER	Based on the setting chosen, the AQ251 closes the AUX. Out dry contact terminals when: <ul style="list-style-type: none"> • BOILER: The boiler pump energizes. • SETBACK: The system program is in setback mode (either SLEEP or LEAVE). • ZONE OP.: The end switch of a zone valve connected to a Zoning Module closes or a zone pump energizes. • ALARM: An alarm is detected on the system. • AUX.IN, DHW IN, HEAT IN, or HEAT DMND: An input signal is detected on the respective terminals. • COOL: There is a call for cooling from a programmable AQ1000 thermostat. The COOL option is available <u>only</u> if central A/C is present; see the “A/C SETTINGSa” and “A/C EQUIP CONFIG” menu options in this table. • NONE: indicates that the Aux Out terminals are not used.
AUXILIARY I/O (continued)			
AUX.PUMP (optional)	BOILER / GROUP / OCC / BYPASS / FAN / NONE / AUX.IN / DHW IN / HEAT IN / HT DMND	BOILER	Based on the setting chosen, the AQ251 closes the Aux. Pump dry contacts when: <ul style="list-style-type: none"> • BOILER: The boiler pump energizes. • GROUP: Any of the thermostats in a Group of zones (identified by the Zoning Module's DIP switch #7 [AUX] being switched to YES) energize. • OCC: The system program is in Occupied mode (either WAKE or RETRN). • BYPASS: The boiler return sensor measures a water temperature less than the value defined for the EQUIPMENT SETUP > BOILER SETTING > MIN RETURN setting. • FAN: There is a call for cooling from a programmable AQ1000 thermostat. The FAN option is available <u>only</u> if central A/C is present; see the “A/C SETTINGSa” and “A/C EQUIP CONFIG” menu options in this table • AUX.IN, DHW IN, HEAT IN, or HEAT DMND: An input signal is detected on the respective terminals. • NONE: indicates that the Aux Pump terminals are not used.

Table 6. Installer Menu – Equipment Setup. (Continued)

EQUIPMENT SETUP			
Menu Option	Range	Factory Default	Description
A/C SETTINGS^a	Central A/C – Available only if no AQ158 controller is present on the network.		
CYCLES/HOUR	2 / 3 / 4 / 5 / 6	4	The maximum number of times the controller will permit the central A/C to cycle in each hour.
MIN.OFF TIME	2 to 10 (minutes)	5M	The length of time that must elapse after the AC compressor shuts off before the Aux. Out relay is permitted to close, to energize the compressor again.
C.W.S.D.	- - 32°F to 100°F (0°C to 38°C)	65°F (18°C)	The temperature at which cold weather shutdown is activated. • “- -” means Off (not used).
FAN MODE	AUTO / ON	AUTO	Selects whether or not the fan serving the A/C system operates constantly (ON) or operates only when there is a call for cooling (AUTO). FAN MODE displays only if the FAN option is selected for AUX.PUMP. See the AUX.PUMP menu option in this table.
A/C EQUIP CONFIG	Central A/C – Available only if no AQ158 controller is present on the network.		
ZONE	A-1 to D-16	A-1	Selects the desired zone.
A/C UNIT	NONE / 1	1	Defines which A/C compressor is associated with each zone thermostat. NOTE: At this time, only one zone of A/C can be handled by the AQ2000 controls. The options are 1 (if the zone uses an AQ1000TP2 programmable thermostat and can call for cooling), or NONE.
COOLING	ENABLE / DISABLE	ENABLE	Enables or disables the cooling functions of the zone's programmable thermostat (AQ1000TP2). NOTE: This item is always set to DISABLE when a non-programmable thermostat (AQ1000TN2) is used in the selected zone.
STATISTICS	Displays the summary and Zone relay activity (hours of operation or cycles since last reset)		
LAST DATA RESET	Max. 24,855 days (68 years)	2000 JAN 01	Date of last reset formatted as YYYY MMM DD.
RESET ALL DATA ARE YOU SURE?	YES / NO	NO	Selecting YES resets all of the summary and zone activity values to zero.
BOILER FIRE ACTIV	Maximum of 596,523 hours (68 years)	0H	Hours of operation of the relay since last reset.
BOILER PUMP ACTIV	Maximum of 596,523 hours (68 years)	0H	Hours of operation of the relay since last reset.
DHW PUMP ACTIV	Maximum of 596,523 hours (68 years)	0H	Hours of operation of the relay since last reset.
AUX PUMP ACTIV	Maximum of 596,523 hours (68 years)	0H	Hours of operation of the relay since last reset.
AUX OUT ACTIV	Maximum of 596,523 hours (68 years)	0H	Hours of operation of the relay since last reset.
ZONE A-1 ACTIV	Maximum of 596,523 hours (68 years)	0H	Hours of operation of the zone's relay (e.g., zone A-1) since last reset. The zone Identifier is A-1 through D-16.
ENVIRACOM	Not used - reserved for future use.		
Modules ID:	n/a	n/a	n/a

Table 6. Installer Menu – Equipment Setup. (Continued)

EQUIPMENT SETUP			
Menu Option	Range	Factory Default	Description
SAVE / RESTORE	Options for saving settings or restoring previously-saved settings		
RESTORE FACTORY	n/a	n/a	Selecting this option restores all settings to their factory defaults
RESTORE SETUP	n/a	n/a	Selecting this option restores all settings to those saved by the Installer with the SAVE SETUP operation. RESTORE SETUP is only displayed as a menu option if installer settings have previously been saved using the SAVE SETUP menu option. Only displays if the installer has previously saved his (non-factory default) settings using the SAVE SETUP feature.
SAVE SETUP	n/a	n/a	Enables installer to SAVE system settings after the system has been set up and is working well. Designed to facilitate quick recovery to proper system operation in the event of inadvertently changing control settings (e.g., tampering with the system settings by an inexperienced user).

^a Applies only to systems where the zones use an AQ1000TP2 stat and the A/C equipment is connected directly to (and controlled by) the AQ panel. Does not apply when A/C equipment is connected directly to a digital, non-communicating stat.

Table 7. Installer Menu – Test and Purge.

TEST and PURGE			
Menu Option	Range	Factory Default	Description
TEST OUTPUTS	Tests the individual system outputs to ensure correct operation.		
BOILER PUMP	ON / OFF	OFF	Energizes / de-energizes the line voltage terminals marked Boiler when switched to ON / OFF respectively.
AUX PUMP	ON / OFF (close / open)	OFF (open)	Closes / opens the line voltage rated dry contacts marked Aux. when switched to ON / OFF, respectively.
DHW PUMP	ON / OFF	OFF	Energizes / de-energizes the line voltage rated terminals marked DHW when switched to ON / OFF respectively.
BOILER T-T	ON / OFF (close / open)	OFF (open)	Closes / opens the low voltage rated dry contacts (terminals 17 and 18) marked Boiler T-T when switched to ON / OFF respectively.
AUX OUT	ON / OFF (close / open)	OFF (open)	Closes / opens the low voltage rated dry contacts (terminals 19 and 20) marked Aux. Out. when switched to ON / OFF respectively.
10V MOD	0V to 10V	0V	Produces voltage on the 10 Vdc low voltage terminals (17 and 18), according to the setting chosen (0V to 10V), in increments of 1V.
TEST SENSORS	Tests the supply, return and outdoor temperature sensors to ensure correct operation		
OUTDOOR	-- LO -58° to 212°F (-50° to 100°C) HI	n/a	Displays the temperature measured by the outdoor sensor. “-” means sensor is disconnected LO means temperature reading is below -55°F (-50°C) HI means temperature reading is above 212°F (100°C)
BOILER	-- LO -49° to 257°F (-45° to 125°C) HI	n/a	Displays the temperature measured by the boiler supply sensor. “-” means sensor is disconnected LO means temperature reading is below -49°F (-45°C) HI means temperature reading is above 257°F (125°C)
RETURN	-- LO -49° to 257°F (-45° to 125°C) HI	n/a	Displays the temperature measured by the Return/DHW sensor. “-” means sensor is disconnected LO means temperature reading is below -49°F (-45°C) HI means temperature reading is above 257°F (125°C) Does not display when the RETURN/DHW sensor is configured as a DHW sensor.
DHW	-- LO -49° to 257°F (-45° to 125°C) HI	n/a	Displays the temperature measured by the sensor configured for DHW (the sensor wired to the Return/DHW terminals 5 and 6). “-” means sensor is disconnected LO means temperature reading is below -49°F (-45°C) HI means temperature reading is above 257°F (125°C) Displays only when the sensor is configured as a DHW sensor.

Table 7. Installer Menu – Test and Purge. (Continued)

TEST and PURGE			
Menu Option	Range	Factory Default	Description
TEST ZONES	Tests the zone equipment individually, or sequentially, to ensure correct operation		
ALL ZONES	n/a	OFF	Sequentially energizes / de-energizes all zones connected to the AQUATROL network. <ul style="list-style-type: none"> • 0 displays when the Control Module has confirmation that the pump/valve is closed. • 1 displays when the Control Module has confirmation that the pump/valve is fully open. In the case of pump zoning, the 1 displays no more than 5 seconds after the activation of the relay. In the case of valve zoning, the 1 displays either when the zone valve operating time (defined in EQUIPMENT SETUP > ZONING > ZONE VALVES TIME TO OPEN) has elapsed (AQ15540B) or when the valve's end switch is closed (AQ15740B).
ZONE A-1 0 ... ZONE A-16 0	0 / 1	0	Energizes / de-energizes each zone individually. <ul style="list-style-type: none"> • 0 displays when the Control Module has confirmation that the pump/valve is closed. • 1 displays when the Control Module has confirmation that the pump/valve is fully open.
PURGE	Purges all (or individual) zones for the period of time selected in the PURGE TIME menu option		
PURGE TIME	1 to 30 (minutes)	5:00 (minutes)	Duration of purge for each zone selected.
PURGE	ALL / DHW / ZONE A-1 ... ZONE D-16	ALL	Installer selects which zones to purge (all, only DHW, or individual zones).
START PURGE	START PURGE / STOP PURGE	n/a	Starts and Stops purge operation.
PURGE OFF	WAIT VALVE / PURGE COMPLETED	n/a	Indicates status of the system during a Purge operation. Displays only if START PURGE is active.

Menu Structure

This section illustrates the complete menu structure for:

- User Menu
- Installer Menu (see Fig. 25 on page 39)

User Menu Structure

Press the Menu button on the keypad to display the User Menu. Fig. 24 illustrates all possible User Menu selections.

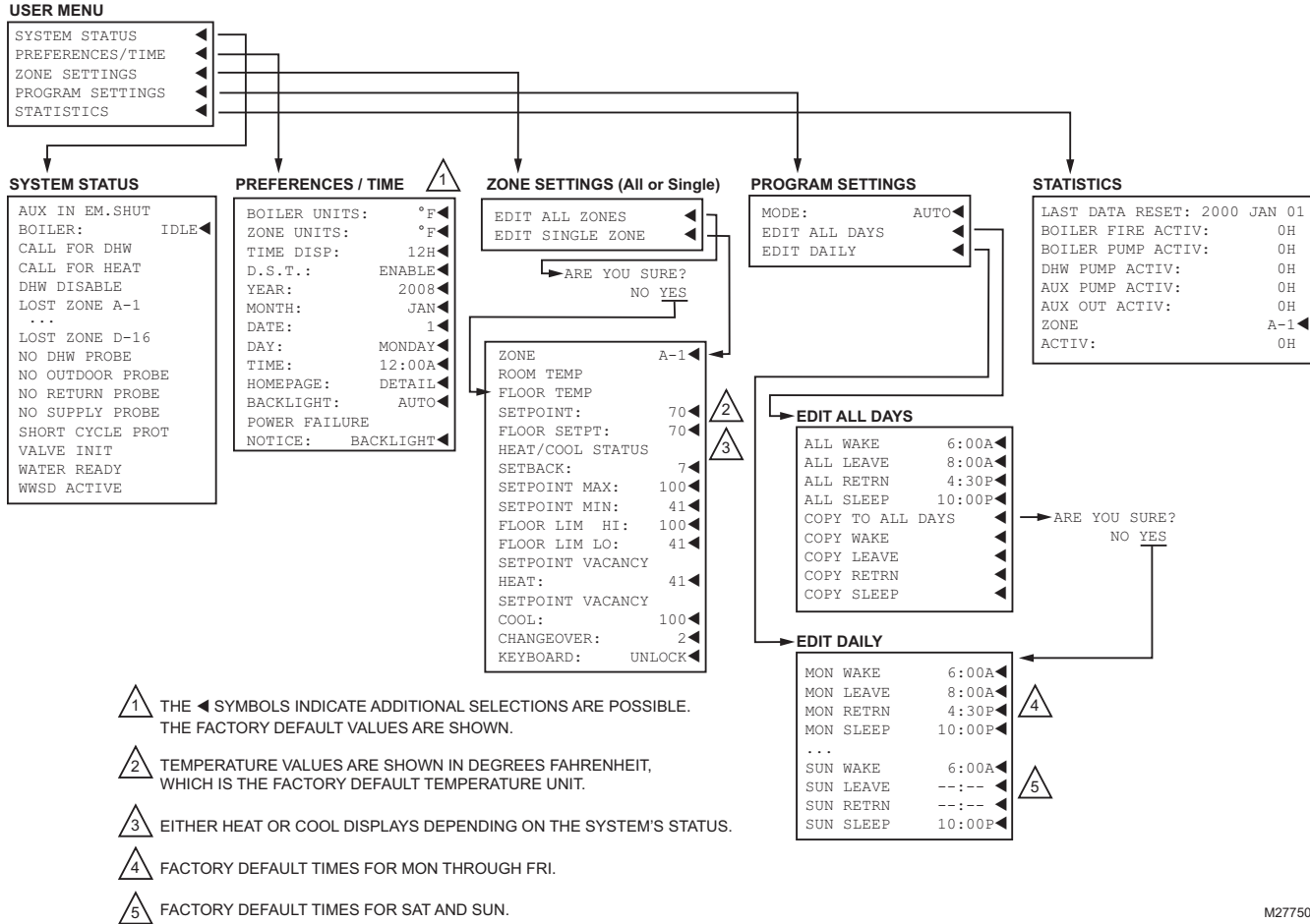

Fig. 24. User Menu Structure.

M27750

Installer Menu Structure

To display the Installer Menu, go to the Home Page, press and hold the OK button for 3 seconds until the message INSTALLER MODE – ARE YOU SURE? displays. Select YES and press the OK button. Fig. 25 and Fig. 26 illustrate all possible Installer Menu selections.

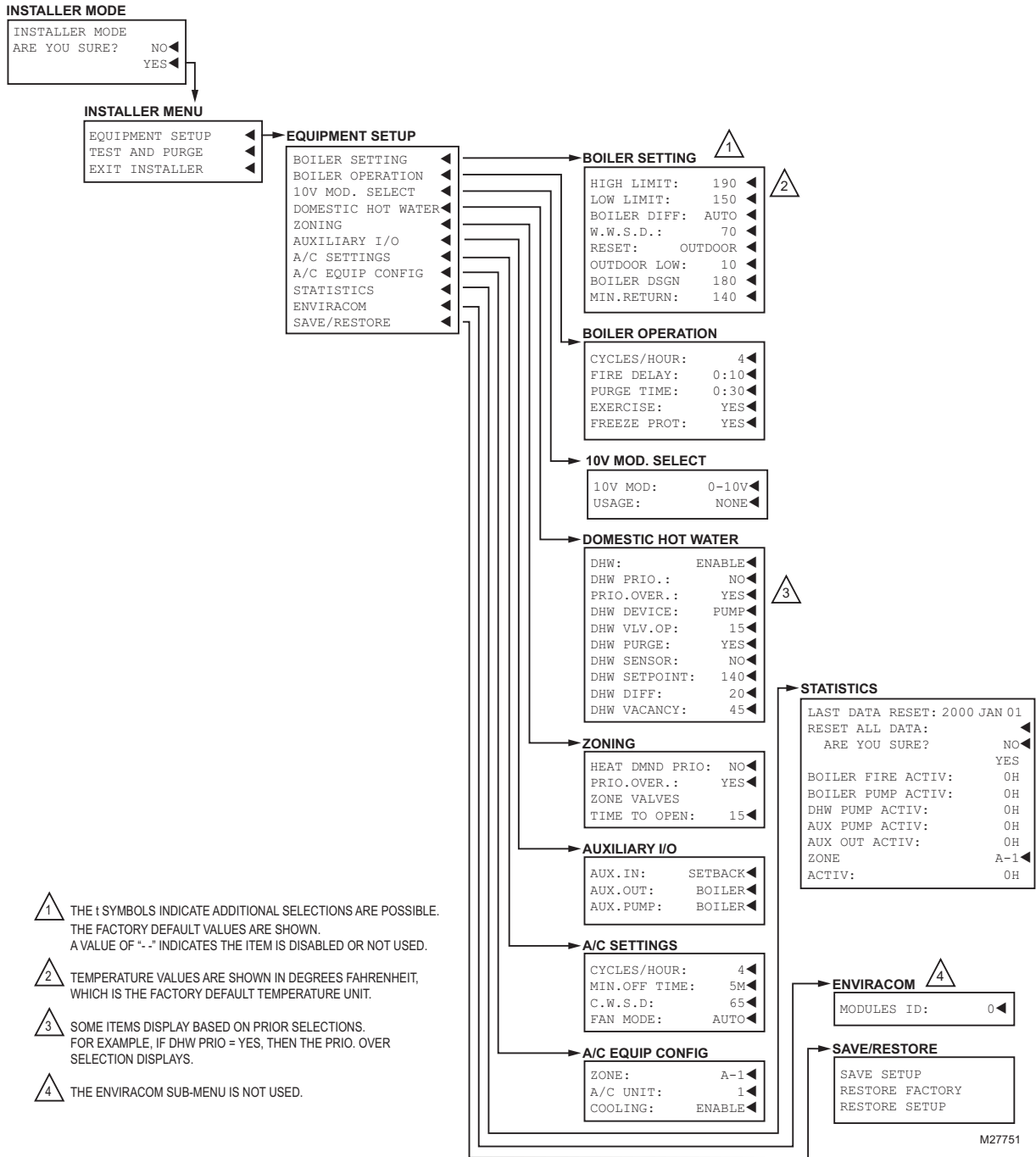

Fig. 25. Installer Menu Structure. – Equipment Setup.

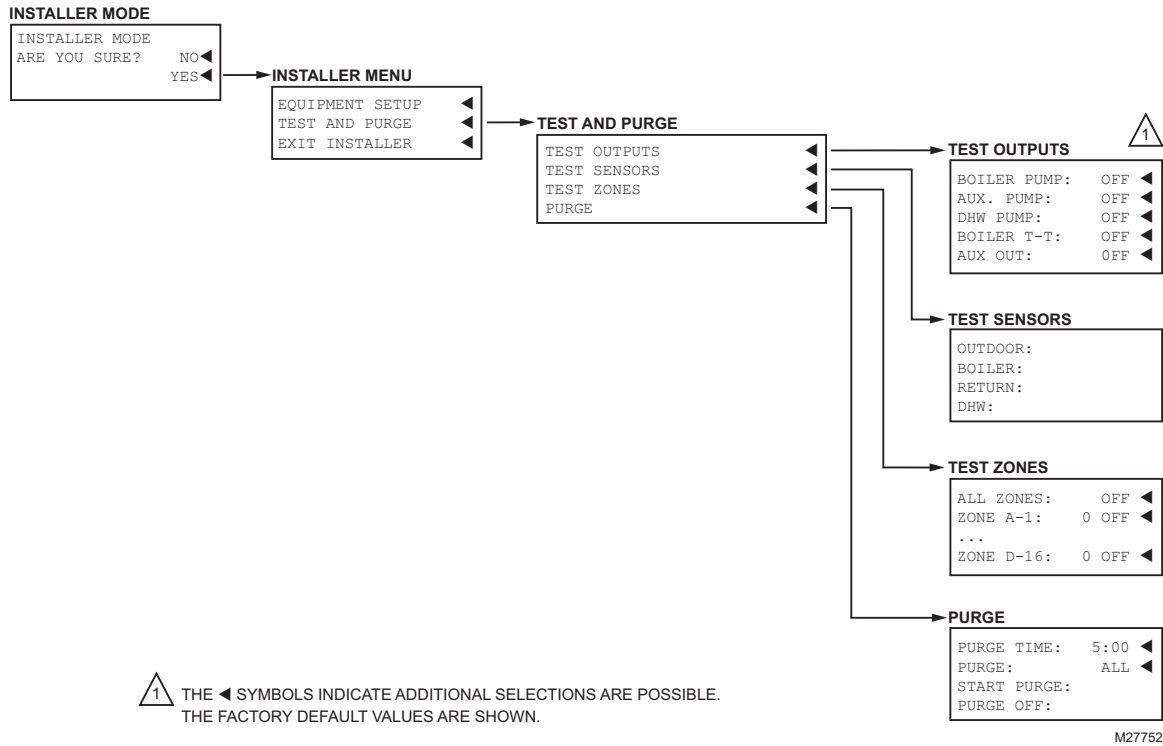

Fig. 26. Installer Menu Structure. – Test and Purge.

AQUATROL® is a registered trademark of Honeywell International Inc.
Aquastat® is a registered trademark of Honeywell International Inc.

Automation and Control Solutions

Honeywell International Inc.
1985 Douglas Drive North
Golden Valley, MN 55422
customer.honeywell.com

