

## AQ25A42B Programmable Boiler Relay Control Panel

System commissioning date: \_\_\_\_\_

Customer: \_\_\_\_\_

Building address: \_\_\_\_\_

This is a legacy product document supported by Resideo. It is no longer manufactured

### INSTALLATION JOB RECORD

#### INSTRUCTIONS:

Fill in the details of the equipment connected to the control module and the zoning module:

- A** Low voltage control module wiring
- B** Low voltage zone thermostats
- C** Line voltage zone pumps or low voltage zone valves without end switches
- D** Line voltage Boiler pump, DHW pump and AUX output
- E** Review and set DIP switch settings - once DIP switches for the zoning module (AQ15540B) have been set, complete the "Installer Settings" diagram by filling in the circles to indicate the DIP switch position set during installation

File this with other installation records for equipment used on this installation.

#### A Boiler Control Module

Terminal #	9-10	13-14	17-18	19-20
Terminal ID	Aux. In	DHW	Boiler	Aux. Out
Function	Installer defined	DHW demand	Boiler demand	Installer defined
Equipment				
Manufacturer				
Model #				
Serial #				
Date Code				
Notes				

#### B Zoning Thermostats

Terminal #	5-6	7-8	9-10	11-12
Terminal ID	TH1	TH2	TH3	TH4
Function	Zone call for heat			
Equipment				
Manufacturer				
Model #				
Date Code				
Notes				

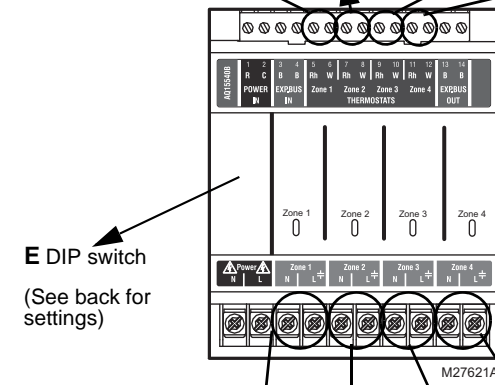
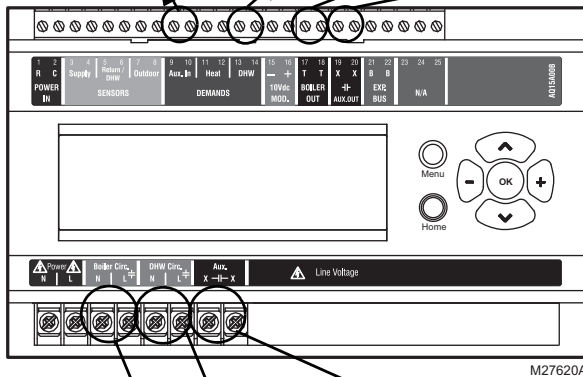

#### C Boiler Pump, DHW, and AUX Device

Terminal ID	Boiler	DHW	Aux
Function	Boiler loop control	DHW loop control	Line voltage-rated Aux. device control (installer-defined)
Equipment			
Manufacturer			
Model #			
Power (Amps)			
Notes			

#### D Zoning Pumps or Valves

Terminal ID	Zone 1	Zone 2	Zone 3	Zone 4
Function	Zone control			
Equipment (circle one)	Pump / Valve	Pump / Valve	Pump / Valve	Pump / Valve
Manufacturer				
Model #				
Date Code				
Power draw Amps (pumps) VA (valves)				
Notes				



## E Zoning Module DIP Switch Settings

DIP Number	Description
1	<b>Zone Address</b>
2	Slide the DIP switch to the right-hand (ON) position to indicate which group of zones this is:
3	The correct DIP switch settings for each zone module are:
4	<ul style="list-style-type: none"> <li>First Zone (1-4) Module: 1 = ON position; 2, 3, and 4 = OFF position</li> <li>Second Zone (5-8) Module: 2 = ON position; 1, 3, and 4 = OFF position</li> <li>Third Zone (9-12) Module: 3 = ON position; 1, 2, and 4 = OFF position</li> <li>Fourth Zone (13-16) Module: 4 = ON position; 1, 2, and 3 = OFF position</li> </ul> <p>For each zone group, there can be only <b>one</b> DIP switch in the right-hand (ON) position.</p>
5	<ul style="list-style-type: none"> <li>If set to SYNC, zone synchronization is enabled.</li> <li>If set to NOT, zone synchronization is disabled.</li> </ul>
6	<ul style="list-style-type: none"> <li>If zone valves are normally closed (N.C.), set the NC/NO DIP switch to the OFF position.</li> <li>If zone valves are normally open (N.O.), set the NC/NO DIP switch to the ON position.</li> </ul>
7	<ul style="list-style-type: none"> <li>If set to Group (ON position), the AUX Pump contacts on the Control Module are switched when any of the zones on this Zoning Module are active.<sup>a</sup></li> <li>If set to - (OFF position), the AUX Pump contacts are not affected by activity on these zones.</li> </ul>
8	<ul style="list-style-type: none"> <li>If set to 2-Stg (ON position), then 2-stage operation is activated on thermostat inputs. The zoning module operates as two 2-stage zones or 3 zones (one 2-stage and two 1-stage).</li> <li>If set to 1-Stg (OFF position), then operates as four 1-stage zones.</li> </ul>

<sup>a</sup> The EQUIPMENT SETUP > AUXILIARY I/O > AUX PUMP menu option on the AQ25A must be set to "GROUP"

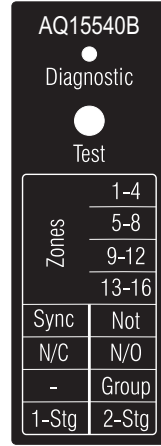

M23720A

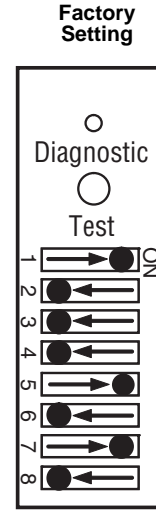

M34972

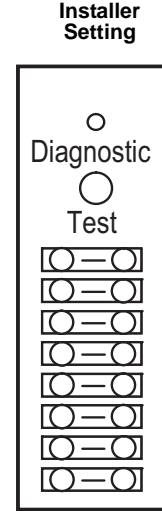

M23715

Fill in the circle to indicate position of DIP switch.

# EQUIPMENT SETTINGS

The Installer Menu is used to establish and modify the system's equipment and option settings. These include equipment settings for boiler operation, DHW management, zoning, auxiliary input/output operation, and option settings such as pump/valve exercise, and freeze protection.

Use Table 1 to record the equipment settings for this installation.

To record the equipment and option settings:

- A** Press the Home button to return to the Home Page display.
- B** Press and hold the OK button for 3 seconds until the message, INSTALLER MODE – ARE YOU SURE?, displays.
- C** Select YES, then press and release the OK button to display the Installer Menu.
- D** Select the Equipment Setup sub-menu.
- E** Record the configured settings in Table 1.
- F** Exit Installer mode by selecting the Installer Exit menu option.

**Table 1. Installer Menu – Equipment Setup Sub-menu.**

EQUIPMENT SETUP SUB-MENU			
Sub-Menu and Option	Range	Factory Default	Equipment Settings Used
<b>BOILER SETTINGS</b>			
HIGH LIMIT	120°F to 225°F (49°C to 107°C)	190°F (88°C)	
LOW LIMIT	60°F to 180°F (15°C to 82°C)	150°F	
BOILER DIFF	2°F to 41°F (1°C to 23°C) / AUTO	AUTO	
W.W.S.D.	-- 35°F to 100°F (2°C to 38°C)	70 °F (21°C)	
MIN. RETURN	-- / 80°F to 180°F (27°C to 82°C)	140 °F (60°C)	
<b>BOILER OPERATION</b>			
CYCLES/HOUR	2 to 6	4	
FIRE DELAY	0 seconds to 3 minutes (in 5 second increments)	10 (seconds)	
PURGE TIME	OFF, 10 seconds to 30 minutes (in 10 second increments)	30 (seconds)	
EXERCISE	YES / NO	YES	
FREEZE PROT	YES / NO	YES	
<b>10V MOD. SELECT</b>			
10V MOD	0-10V / 2-10V	0-10V	
USAGE	NONE / BOILER	NONE	
<b>DOMEST.HOT WATER</b>			
DHW	ENABLE / DISABLE	ENABLE	
DHW PRIO	YES / NO	NO	
PRIO.OVER.	YES / NO	YES	
DHW DEVICE	PUMP / VALVE	PUMP	
DHW VLV.OP	0 - 230 seconds (in 5 second increments)	15 (seconds)	
DHW PURGE	YES / NO	YES	
DHW SENSOR	YES / NO	NO	
DHW SETPOINT	-- 60°F to 160°F (16°C to 71°C)	140°F (60°C)	
DHW DIFF	-- 5°F to 40°F (2.5°C to 22°C)	20°F (-7°C)	
DHW VACANCY	-- [41°F + DHW DIFF] to 160°F [5°C + DHW DIFF] to 71°C)	45°F (7°C)	
<b>ZONING</b>			
HT DMND PRIO	YES / NO	NO	
PRIO.OVER	YES / NO	NO	
ZONING VALVES TIME TO OPEN	5 - 230 (seconds)	15 (seconds)	
HT DMND PRIO	YES / NO	NO	

**Table 1. Installer Menu – Equipment Setup Sub-menu. (Continued)**

<b>EQUIPMENT SETUP SUB-MENU</b>			
<b>Sub-Menu and Option</b>	<b>Range</b>	<b>Factory Default</b>	<b>Equipment Settings Used</b>
<b>AUXILIARY I/O</b>			
AUX.IN (optional)	SETBACK / VACANCY / EM. SHUT / NONE	SETBACK	
AUX.OUT (optional)	BOILER / SETBACK / ZONE OP. / ALARM / AUX.IN / DHW IN / HEAT IN / HT DMND / COOL / NONE	BOILER	
AUX.PUMP (optional)	BOILER / GROUP / OCC / BYPASS / FAN / NONE / AUX.IN / DHW IN / HEAT IN / HT DMND	BOILER	
<b>A/C SETTINGS</b>			
CYCLES/HOUR	2 / 3 / 4 / 5 / 6	4	
MIN.OFF TIME	2 to 10 (minutes)	5M	
C.W.S.D.	- - 32°F to 100°F (0°C to 38°C)	65°F (18°C)	
FAN MODE	AUTO / ON	AUTO	
<b>A/C EQUIP CONFIG</b>			
ZONE	A-1 to D-16	A-1	
A/C UNIT	NONE / 1	1	
COOLING	ENABLE / DISABLE	ENABLE	
<b>ENVIRACOM</b> (not used at this time - reserved for future use)			
Modules ID:	n/a	n/a	

**Automation and Control Solutions**

Honeywell International Inc.  
1985 Douglas Drive North  
Golden Valley, MN 55422  
customer.honeywell.com

© U.S. Registered Trademark  
© 2013 Honeywell International Inc.  
69-2121—05 L.L. Rev. 10-13  
Printed in United States

