

This is a legacy product document supported by Resideo. It is no longer manufactured

Honeywell

VR9205R Series 1000

Direct Ignition Gas Control with Integrated Gas/Air Module

INSTALLATION INSTRUCTIONS

APPLICATION

The VR9205R Direct Ignition Gas Controls with Integrated Gas/Air Module have been developed for application in domestic appliances with premix or atmospheric burners and automatic ignition requiring a redundant gas valve. They have been optimized for direct ignition applications. The gas/air module is designed to amplify and modulate the outlet gas pressure by means of a pneumatic link

between the gas and air flow by using the air pressure difference. The valve may be used on either Natural gas or LP gas applications.

- Valve capacities are shown in Table 1.
- For suffix letter designation, see Table 2.

Table 1. Valve Capacity.^a

Model	Size Inlet-Outlet (in.)	AGA Certified Capacity	AGA Certified Minimum Regulation	AGA Certified Maximum Regulation
		KBtu/h	KBtu/h	KBtu/h
VR9205R	1/2 x 1/2	140	20 ^b	200

^a Capacity based on 1000 Btu/ft³, 0.64 sp gr natural gas at 1 in. wc pressure drop (37.3 MJ/m³, 0.64 sp gr natural gas at 0.25 kPa pressure drop).

^b Minimum and Maximum regulation is at the max fire. Minimum regulation at low fire is 9 KBtu/h at 0.7 in. WC outlet pressure.

Table 2. Model Number Suffix Letter Designation.

Model Number Suffix Letter	Ambient Temperature Range	Pressure Regulator Type
R	32°F to 158°F (0°C to 70°C)	Standard opening with integrated gas/air module

SPECIFICATIONS

Body Pattern: Straight through; see Table 1 for inlet and outlet size.

Electrical Ratings:

Voltage and Frequency: 24 Vac, 50/60 Hz.
Current Draw: 0.4A.

Capacity: See Table 1.

Regulation Range: See Table 1.

Natural-LP Gas Conversion Kits: Valve is not convertible.

Approvals:

CSA Design Certificate. File # LR 112491



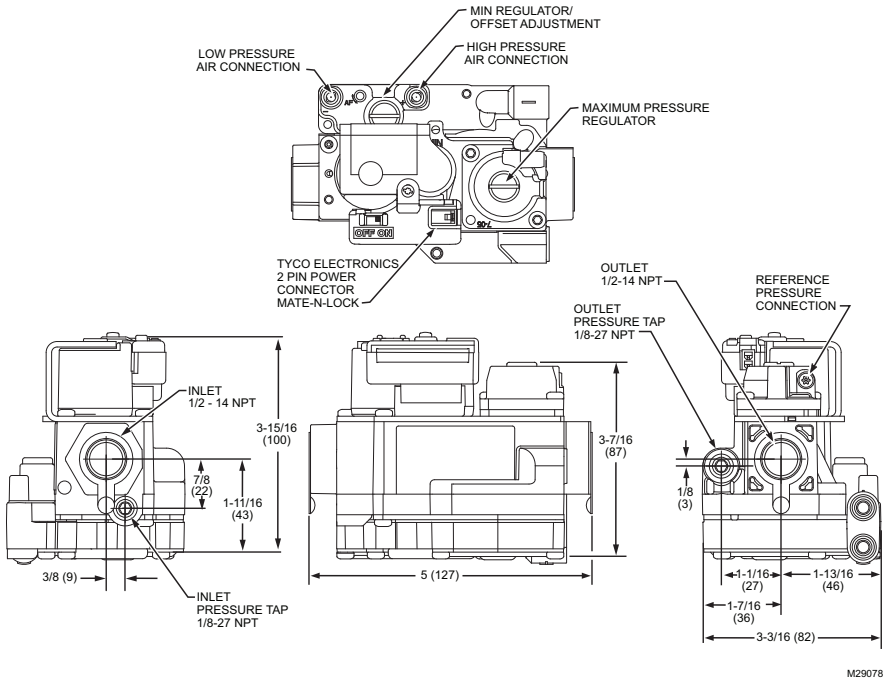

Fig. 1. VR9205R Series 1000 Direct Ignition Gas Control.

PLANNING THE INSTALLATION

⚠ WARNING

Fire or Explosion Hazard.
Can cause property damage, severe injury, or death.

Follow these warnings exactly:

1. Plan the installation as outlined below.
2. Plan for frequent maintenance as described in the Maintenance section.

Heavy demands are made on the controls when direct ignition systems are used on central heating equipment in barns, greenhouses, and commercial properties and on heating appliances such as commercial cookers, agricultural equipment, industrial heating equipment and pool heaters.

Special steps may be required to prevent nuisance shutdowns and control failure due to frequent cycling, severe environmental conditions related to moisture, corrosive chemicals, dust or excessive heat. These applications require Honeywell Combustion Engineering review; contact your Honeywell Sales Representative for assistance.

Review the following conditions that can apply to your specific installation and follow the precautions suggested.

Frequent Cycling

This control is designed for use on appliances that typically cycle three to four times an hour only during the heating season. In year-around applications with greater cycling rates, the control can wear out more quickly. Perform a monthly checkout.

Water or Steam Cleaning

If a control gets wet, replace it. If the appliance is likely to be cleaned with water or steam, protect (cover) the control and wiring from water or steam flow. Mount the control high enough above the bottom of the cabinet so it does not get wet during normal cleaning procedures.

High Humidity or Dripping Water

Dripping water can cause the control to fail. Never install an appliance where water can drip on the control. In addition, high ambient humidity can cause the control to corrode and fail. If the appliance is in a humid atmosphere, make sure air circulation around the control is adequate to prevent condensation. Also, regularly check out the system.

Corrosive Chemicals

Corrosive chemicals can attack the control, eventually causing a failure. If chemicals are used for routine cleaning, avoid contact with the control. Where chemicals are suspended in air, as in some industrial or agricultural applications, protect the control with an enclosure.

Dust or Grease Accumulation

Heavy accumulations of dust or grease can cause the control to malfunction. Where dust or grease can be a problem, provide covers for the control to limit contamination.

Heat

Excessively high temperatures can damage the control. Make sure the maximum ambient temperature at the control does not exceed the rating of the control. If the appliance operates at very high temperatures, use insulation, shielding, and air circulation, as necessary, to protect the control. Proper insulation or shielding should be provided by the appliance manufacturer; verify proper air circulation is maintained when the appliance is installed.

INSTALLATION

When Installing this Product...

1. Read these instructions carefully. Failure to follow them could damage the product or cause a hazardous condition.
2. Check the ratings given in the instructions and on the product to make sure the product is suitable for your application.
3. Installer must be a trained, experienced service technician.
4. After installation is complete, check out product operation as provided in these instructions.

⚠ WARNING

Fire or Explosion Hazard.
Can cause property damage, severe injury or death.

Follow these warnings exactly:

1. Disconnect power supply before wiring to prevent electrical shock or equipment damage.
2. To avoid dangerous accumulation of fuel gas, turn off gas supply at the appliance service valve before starting installation, and perform Gas Leak Test after installation is complete.
3. Always install a sediment trap in gas supply line to prevent contamination of gas control.
4. Do not force the on-off switch. Use only your fingers to operate the on-off switch. Never use any tools. If the electronic on-off switch does not operate by hand, the gas control should be replaced by a qualified service technician. Force or attempted repair may result in fire or explosion.
5. Plan the installation as outlined below.
6. Plan for frequent maintenance as described in the maintenance section.

Mounting position

The valve can be mounted 0 to 90 degrees in any direction from the top of the valve facing up, including outlet facing upward or downward. See Fig. 2. If the valve is mounted horizontally; the top of the valve must be even with or above the center line of the piping.

NOTE: A deviation of more than 3° from the OEM's original design mounting orientation can result in an unacceptable change in gas outlet pressure. See OEM application installation guide.

To prevent blockage due to condensation, the positive air pressure connection should not be connected to combustion products.

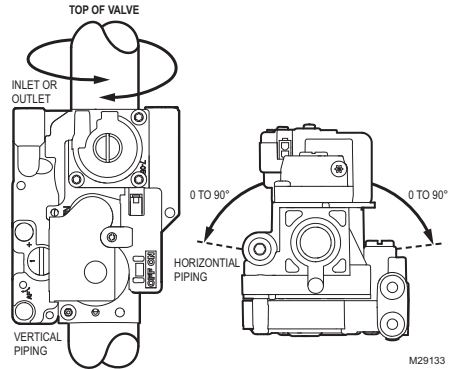

Fig. 2. VR9205R Series 1000 mounting.



CAUTION

Equipment Damage Hazard.
Can burn out thermostat or transformer.
Applying a jumper across (or shorting) the valve coil terminals, even temporarily, can burn out the thermostat or transformer.

Follow the appliance manufacturers instructions if available; otherwise use these instructions as a guide.

IMPORTANT

These gas controls are shipped with protective seals over the inlet and outlet tapplings. Do not remove the seals until ready to install adapters or connect the piping.

Converting Gas Control from Natural Gas to LP Gas (or LP Gas to Natural Gas)



WARNING

Fire Or Explosion Hazard.
Can cause property damage, severe injury or death.
VR9205R cannot be converted between LP or Natural gas. To convert, see appliance manufacturer for recommendations.

Install Bushings To Control

If bushings are being installed on the control, mount them as follows:

Bushings

1. Remove the seal over the control inlet or outlet.
2. Apply a moderate amount of good quality pipe compound to the bushing, leaving two end threads bare. On an LP installation, use compound that is resistant to LP gas. Do not use Teflon tape.
3. Insert the bushing in the control and carefully thread the pipe into the bushing until tight.

Complete the instructions below for installing the piping, installing the control, connecting the wiring. Make sure the leak test you perform on the control after completing the installation includes leak testing the bushings.

- Connect the pipe to the control inlet and outlet. Use a wrench on the square end or a socket on the hex end of the control. See Fig. 5.

Location

The gas controls are mounted in the appliance vestibule on the gas manifold. If this is a replacement application, mount the gas control in the same location as the old control.

Locate the combination gas control where it cannot be affected by steam cleaning, high humidity, or dripping water, corrosive chemicals, dust or grease accumulation or excessive heat.

To assure proper operation, follow these guidelines:

- Locate gas control in a well-ventilated area.
- Mount gas control high enough above cabinet bottom to avoid exposure to flooding or splashing water.
- Assure the ambient temperature does not exceed the ambient temperature ratings for each component.
- Cover gas control if appliance is cleaned with water, steam, or chemicals or to avoid dust and grease accumulation.
- Avoid locating gas control where exposure to corrosive chemical fumes or dripping water are likely.

Install Piping to Control

All piping must comply with local codes and ordinances or with the National Fuel Gas Code (ANSI Z223.1, NFPA No. 54), whichever applies. Tubing installation must comply with approved standards and practices.

- Use new, properly reamed pipe that is free from chips. If tubing is used, make sure the ends are square, deburred and clean. All tubing bends must be smooth and without deformation.
- Run pipe or tubing to the control. If tubing is used, obtain a tube-to-pipe coupling to connect the tubing to the control.
- Install a sediment trap in the supply line to the control. See Fig. 3.

Install Control

- Mount with the coils 90 degrees from the vertical upright position.
- Mount so the gas flow is in the direction of the arrow on the bottom of the control.
- Thread the pipe the amount shown in Table 3 for insertion into control or adapters. Do not thread pipe too far. Valve distortion or malfunction can result if the pipe is inserted too deeply.
- Apply a moderate amount of good quality pipe compound (do not use Teflon tape) only to the pipe, leaving two end threads bare. On LP installations, use a compound resistant to LP gas. See Fig. 4.
- Remove the seals over the control inlet and outlet before installing pipe.

Table 3. NPT Pipe Thread Length.^a

Pipe Size	Thread Pipe This Amount	Maximum Depth Pipe can be Inserted into Control
3/8 ^b	9/16	3/8
1/2	3/4	1/2

^a All dimensions are in inches.

^b OK when bushings are used.

Air pressure connections

The air pressure difference must be connected to the two air pressure connections. See Fig. 1.

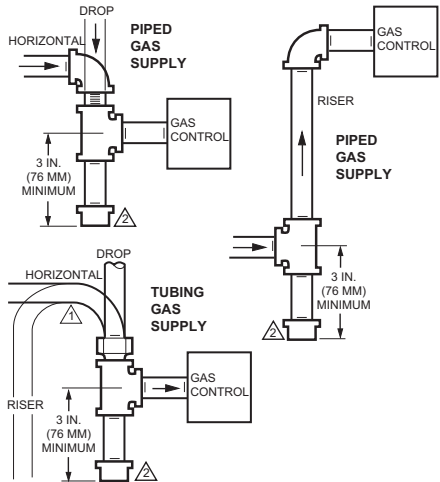

△ ALL BENDS IN METALLIC TUBING SHOULD BE SMOOTH.

△ CAUTION: SHUT OFF THE MAIN GAS SUPPLY BEFORE REMOVING END CAP TO PREVENT GAS FROM FILLING THE WORK AREA. TEST FOR GAS LEAKAGE WHEN INSTALLATION IS COMPLETE. M3077

Fig. 3. Sediment trap installation.

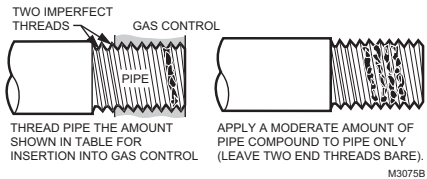

Fig. 4. Use moderate amount of pipe compound.

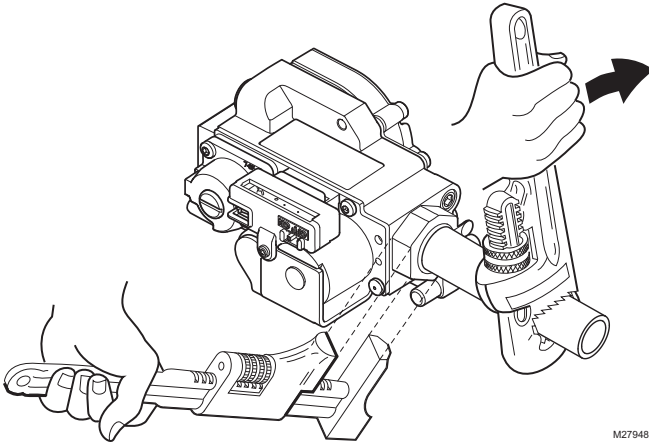

Fig. 5. Proper use of wrench on gas control.

M27948

Wiring

⚠ WARNING

Electrical Shock Hazard.
Can cause severe injury, death or property damage.

Disconnect the power supply before making wiring connections. More than one disconnect may be involved.

Follow the wiring instructions furnished by the appliance manufacturer, if available, or use the general instructions provided below. When these instructions differ from the appliance manufacturer, follow the appliance manufacturer instructions.

All wiring must comply with applicable electrical codes and ordinances.

1. Disconnect power supply before making wiring connections to prevent electrical shock or equipment damage.
2. Check the power supply rating on the gas control and make sure it matches the available supply. Install a transformer and other controls as required.
3. Connect the control circuit to the gas control terminals.
4. Ensure combustion chamber is free of gas before startup.
5. Adjust thermostat heat anticipator to the rating stamped on valve operator.

On-Off Switch

The on-off switch settings are as follows:

- OFF: Prevents main gas flow through the control.
- ON: Permits gas to flow into the control body. Under control of the thermostat and direct ignition module, gas can flow to the main burners.

⚠ CAUTION

Equipment damage.
Can burn out valve coil terminals.
Never apply a jumper across (or short) the valve coil terminals, even temporarily.

IMPORTANT

These gas controls are shipped with protective seals over the inlet and outlet tapings. Do not remove the seals until ready to install adapters or connect the piping.

STARTUP AND CHECKOUT

On-Off Switch

The on-off switch settings are as follows:

- OFF: Prevents main gas flow through the control.
- ON: Permits gas to flow into the control body. Under control of the thermostat and direct ignition module, gas can flow to the main burners.

NOTE: Controls are shipped with the electronic on-off switch in the ON position.

Perform Gas Leak Test

⚠ WARNING

Fire or Explosion Hazard.
Can cause property damage, severe injury or death.
Perform Gas Leak Test every time work is done on a gas system.

IMPORTANT

Do not spray soap and water solution on the gas control. Do not use an excessive amount of soap and water solution to perform the gas leak test. These can damage the control.

Gas Leak Test

1. Paint pipe connections upstream of the gas control with rich soap and water solution. Bubbles indicate a gas leak.
2. If a leak is detected, tighten the pipe connections.
3. Light the main burner. Stand clear of the main burner while lighting to prevent injury caused from hidden leaks that could cause flashback in the appliance vestibule.
4. With the main burner in operation, paint the pipe joints (including bushings) and the control inlet and outlet with rich soap and water solution.
5. If another leak is detected, turn the gas control to off, tighten the joints and pipe connections.
6. Replace the part if a leak cannot be stopped.

Turn On System

Push the on-off switch to the ON position.

Turn On Main Burner

Follow appliance manufacturer instructions or turn thermostat up to call for heat.

Adjustment

Amplification Factor is NOT adjustable on this control.

Do not adjust regulator if cap is sealed.

Refer to the instructions below for making adjustments to the offset or the maximum regulator setting if the cap is not sealed.

IMPORTANT

1. *Do not exceed input rating stamped on appliance nameplate or manufacturer's recommended burner orifice size(s). Make certain primary air supply to main burner is properly adjusted for complete combustion. Follow appliance manufacturer instructions.*
2. *IF CHECKING GAS INPUT BY CLOCKING GAS METER: Make certain there is no gas flow through the meter other than to the appliance being checked. Other appliances must remain off with the pilots extinguished (or deduct their consumption from the meter reading). Convert flow rate to Btuh as described in form 70-2602, Gas Controls Handbook, and compare to Btuh input rating on appliance nameplate.*
3. *IF CHECKING GAS INPUT WITH MANOMETER: Make sure the gas control is in the OFF position before removing outlet pressure tap plug to connect manometer (pressure gauge). Also slide the gas control switch to the OFF position when removing the gauge and replacing the plug. Before removing inlet pressure tap plug, shut off gas supply at the manual valve in the gas piping to the appliance or, for LP, at the tank. Also shut off gas supply before disconnecting manometer and replacing plug. Repeat Gas Leak Test at plug with main burner operating.*

Pressure Tap

The combination gas control is provided with 1/8-in. NPT pressure tap plugs. The gas air module is provided with 9 mm O.D. tubing connections to sense the high and the low combustion air pressure.



CAUTION

To ensure a safe closing of the valves, it is essential that power supplied to the gas valve be disconnected.

Minimum Regulator/Offset adjustment on outlet pressure

- If cap screw is not sealed, remove cap screw to expose adjustment screw.
- Check gas supply pressure to the appliance with the valve flowing gas at max using a pressure gauge connected to the inlet pressure tap.
- Control the fan to produce the air pressure difference stated by the appliance manufacturer.
- Energize the gas valve in order to have gas supplied to the burner. The main burner should ignite within 3 seconds.
- Turn the minimum outlet pressure adjustment screw slowly until the desired pressure is obtained. Turn adjustment screw counter clockwise to increase or clockwise to decrease outlet pressure.
- Replace and tighten cap screw and pressure tap plugs.

IMPORTANT

Adjustments must be made in the final gas valve mounting position to avoid shift caused by the orientation.

- *Turn offset adjustment screw counter clockwise to increase or clockwise to decrease outlet pressure.*
- *Replace and tighten cap screw and pressure tap plugs.*

Maximum outlet pressure adjustment. See Fig. 1.

The maximum outlet pressure adjustment is used to limit the load supplied to the main burner.

- Remove cap screw to expose regulator adjustment screw.
- Determine the value to which the maximum outlet pressure is to be set. Adjustments must be made when the main burner is burning and the fan is in the maximum air flow position.
- Turn the maximum outlet pressure adjustment screw slowly until the desired pressure is obtained. Turn adjustment screw clockwise to increase or counter clockwise to decrease outlet pressure.
- Replace and tighten cap screw and pressure tap plugs.

Check Safety Shutdown Performance



WARNING

Fire or Explosion Hazard.
Can cause severe injury, death, or property damage.

Perform the safety shutdown test any time work is done on a gas system.

NOTE: Read steps 1 through 7 before starting, and compare to the safety shutdown or safety lockout tests recommended for the direct ignition (DI) module. Where different, use the procedure recommended for the module.

1. Turn off gas supply.
2. Set thermostat or controller above room temperature to call for heat.

3. Watch for ignition spark or for glow at hot surface igniter either immediately or following prepurge. See DI module specifications.
4. Time the length of spark operation. See the DI module specifications.
5. After the module locks out, enable the on/off switch and make sure no gas is flowing to the main burner.
6. Set the thermostat below room temperature and wait one minute.
7. Operate system through one complete cycle to make sure all controls operate properly.

5. If proper voltage is present, replace gas control.

INSTRUCTIONS TO THE HOMEOWNER

WARNING

Fire or Explosion Hazard.
Can cause property damage, severe injury, or death.

Follow these warnings exactly:

1. Before lighting, smell around the appliance for gas. Be sure to smell next to the floor because LP gas is heavier than air. If you smell gas:
 - a. Turn off the gas supply at the appliance service valve. On LP gas systems, turn off the gas supply at the gas tank.
 - b. Do not light any appliances in the house.
 - c. Do not touch electrical switches or use the phone.
 - d. Leave the building and use a neighbor's phone to call your gas supplier.
 - e. If you cannot reach your gas supplier, call the fire department.
2. Replace the gas control in the event of any physical damage, tampering, bent terminals, missing or broken parts, stripped threads, or evidence of exposure to heat.

MAINTENANCE

Under normal circumstances no maintenance or service is required.

WARNING

Fire or Explosion Hazard.
Can cause property damage, severe injury, or death.

Do not disassemble the gas control; it contains no replaceable components. Attempted disassembly, repair, or cleaning can damage the control, resulting in gas leakage.

SERVICE

WARNING

Fire or Explosion Hazard.
Can cause severe injury, death, or property damage.

Do not disassemble the gas control; it contains no replaceable components. Attempted disassembly, repair, or cleaning can damage the control, resulting in gas leakage.

CAUTION

Equipment Damage Hazard.
Can burn out thermostats or other components in the control string.

Never apply a jumper across (or short) the valve coil terminals, even temporarily.

IMPORTANT

These gas controls are shipped with protective seals over the inlet and outlet tappings. Do not remove the seals until ready to install adapters or connect the piping.

After servicing, verify proper system operation.

If Main Burner Does Not Come On With Call For Heat

1. Confirm the gas control switch is in the ON position.
2. Adjust thermostat several degrees above room temperature.
3. Using an AC voltmeter, measure across the two terminals on the gas valve.
4. If voltage is incorrect or not present, check control circuit for proper operation.

IMPORTANT

Follow the operating instructions provided by the heating appliance manufacturer. The information below describes a typical control application, but the specific controls used and the procedures outlined in your appliance manufacturer instructions can differ, requiring special instructions.

To Turn ON Appliance

STOP! Read the Warnings Above Before Proceeding.

1. The lighting sequence on this appliance is automatic; *do not attempt to manually light the main burner.*
2. If the furnace does not come on when the thermostat is set several degrees above room temperature, set the thermostat to its lowest setting to reset the safety control.
3. Remove the burner access panel if provided on your appliance.
4. Push the on-off switch to the OFF position.
5. Wait five minutes to allow any gas in the combustion chamber to vent. Then if you smell gas, STOP! Follow Step 1 in the Warning above. If you do not smell gas, continue with the next step.
6. If you do not smell gas, push the electronic on-off switch to the ON position.
7. Replace the burner access panel.
8. Reset the thermostat to the desired temperature.
9. If the appliance does not turn on, slide the switch to OFF and contact a qualified service technician for assistance.

Turning Off the Appliance

Vacation Shutdown

Set the thermostat to the desired room temperature while you are away.

Complete Shutdown

1. Turn off power to the appliance.
2. Turn off the gas supply to the appliance.
3. Push the on-off switch to the OFF position. Appliance will completely shut off.
4. Follow the procedure in the Instructions to the Homeowner section above to resume normal operation.

Automation and Control Solutions

Honeywell International Inc.
1985 Douglas Drive North
Golden Valley, MN 55422
customer.honeywell.com

Honeywell Limited-Honeywell Limitée
35 Dynamic Drive
Toronto, Ontario M1V 4Z9

® U.S. Registered Trademark
© 2009 Honeywell International Inc.
69-2305—03 M.S. Rev. 02-09



Printed in U.S.A. on recycled paper containing at least 10% post-consumer paper fibers.

Honeywell